

Type A1M

40 sq.m. / 431 sq.ft.
Including 3 sq.m. / 32 sq.ft. of Balcony

#03-08 to #04-08

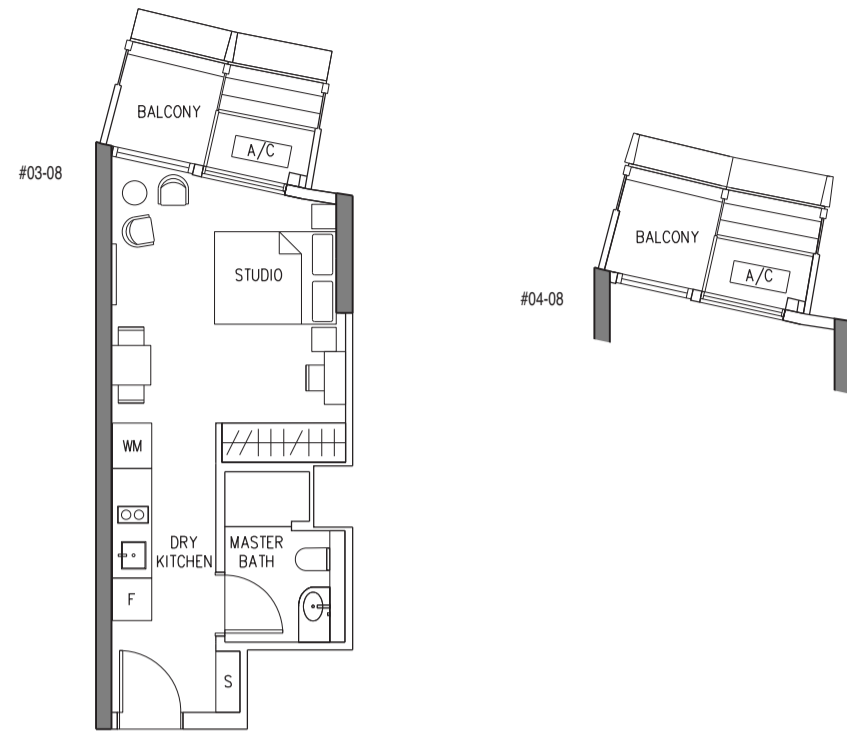
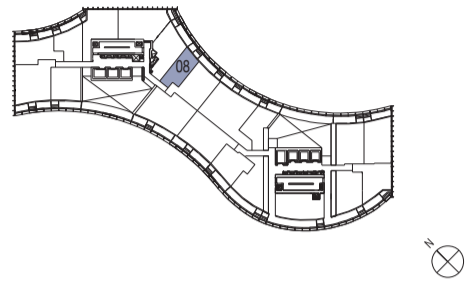

Type B1M / B1

60 sq.m. / 646 sq.ft.
Including 9 sq.m. / 97 sq.ft. of Balcony

#03-01 to #04-01 (B1M)
#05-01 to #30-01 (B1)

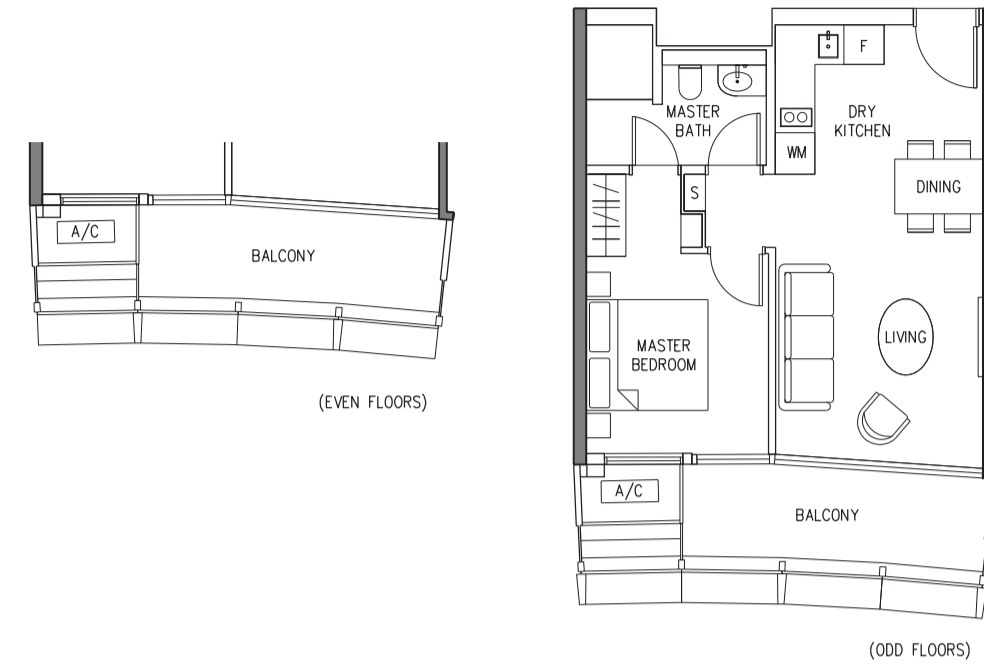
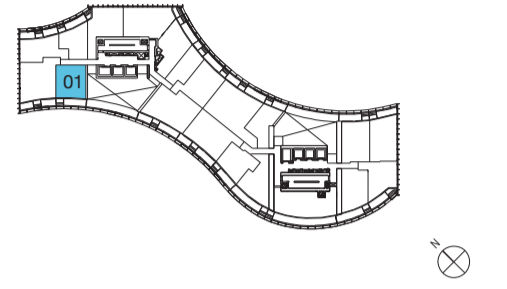

Type A1

39 sq.m. / 420 sq.ft.
Including 3 sq.m. / 32 sq.ft. of Balcony

#05-08 to #30-08

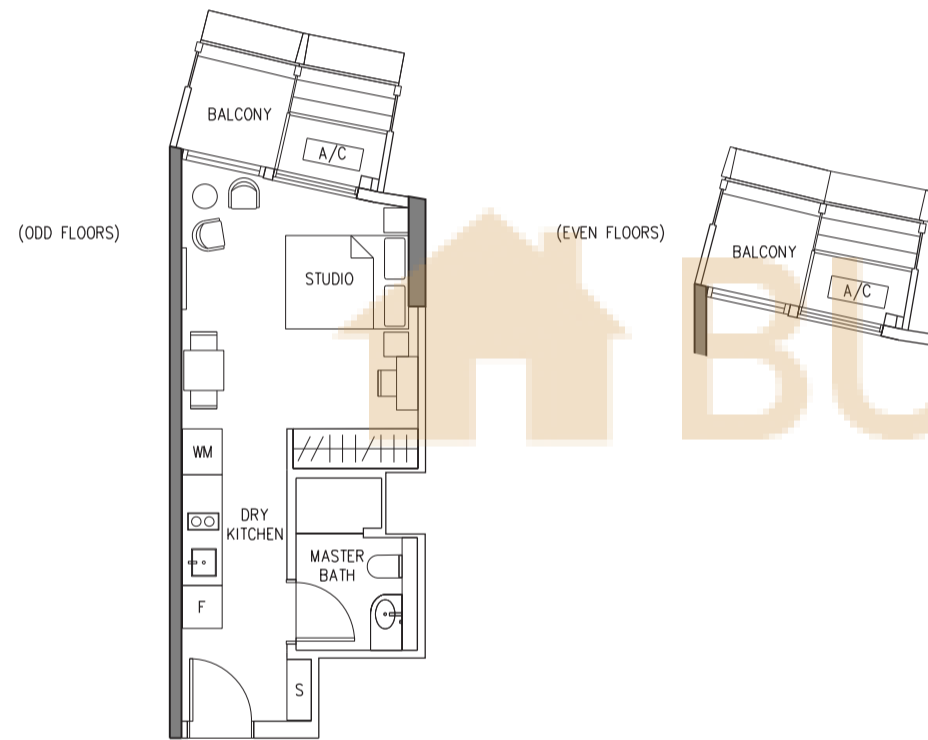
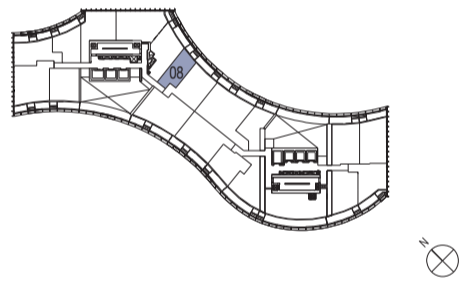

Type B2M / B2

50 sq.m. / 538 sq.ft.
Including 9 sq.m. / 97 sq.ft. of Balcony

#03-04 to #04-04 (B2M)
#05-04 to #30-04 (B2)

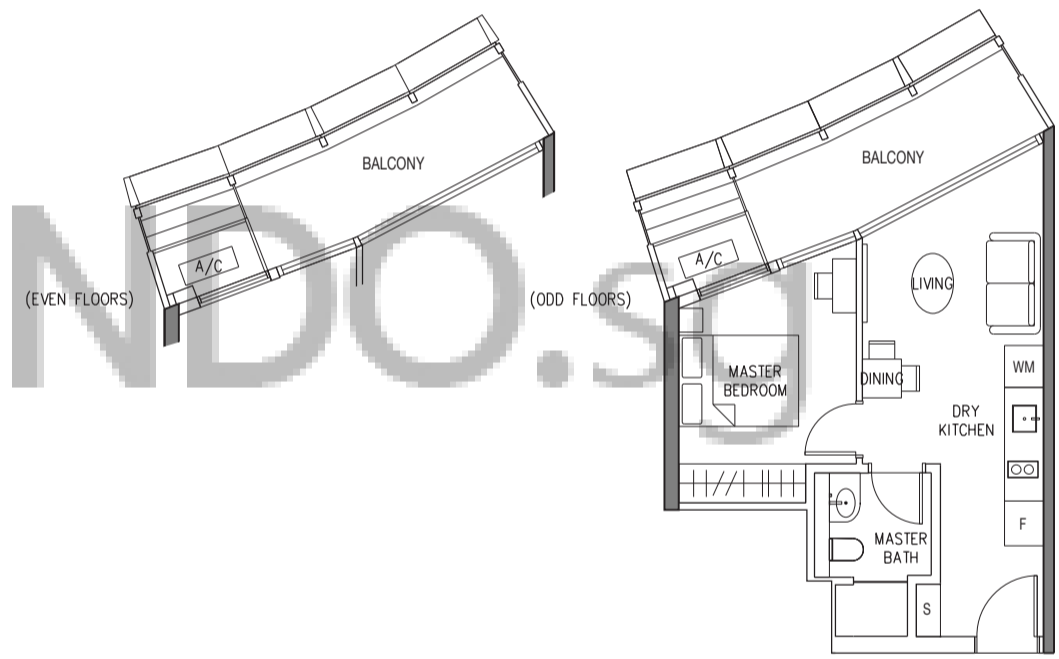
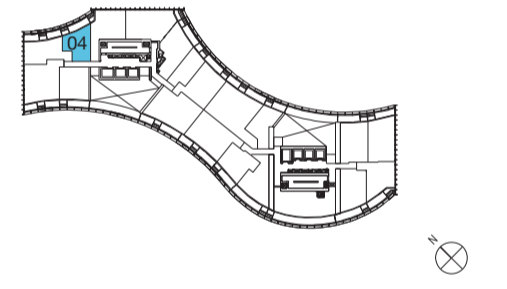

Type A2M / A2

49 sq.m. / 527 sq.ft.
Including 6 sq.m. / 65 sq.ft. of Balcony

#03-16 to #04-16 (A2M)
#05-16 to #30-16 (A2)

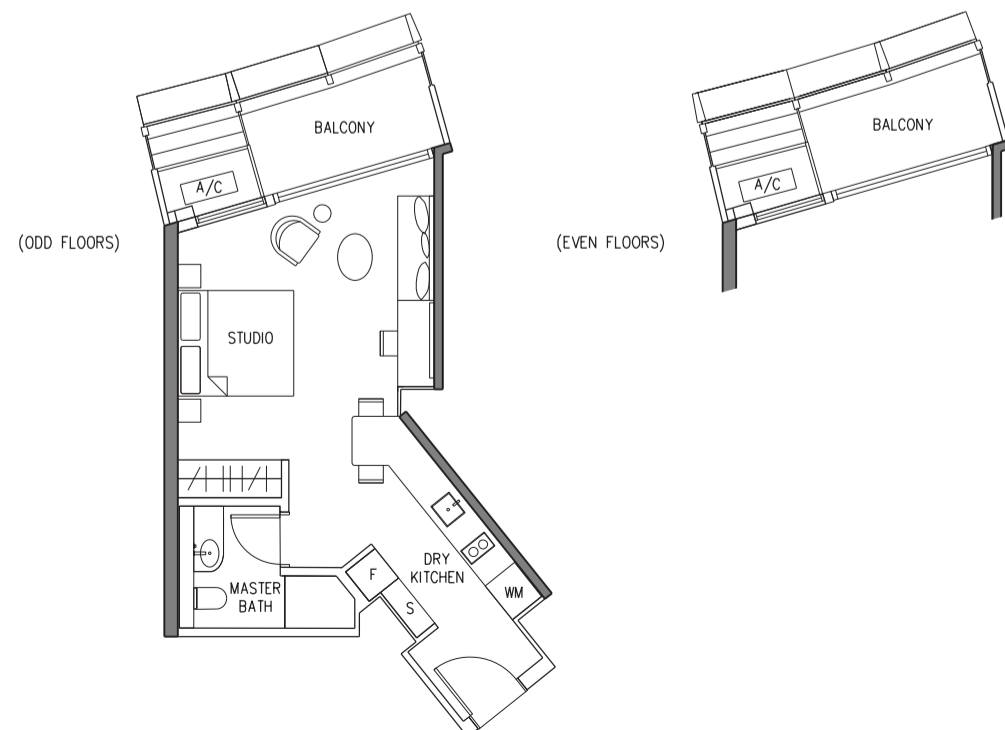
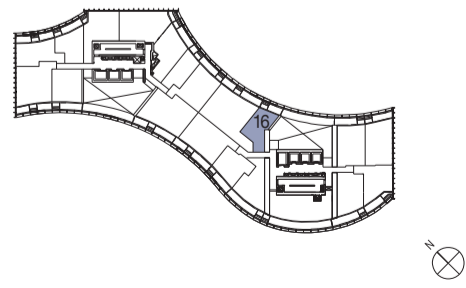

Type B3M / B3

60 sq.m. / 646 sq.ft.

#03-05 to #04-05 (B3M)
#05-05 to #30-05 (B3)

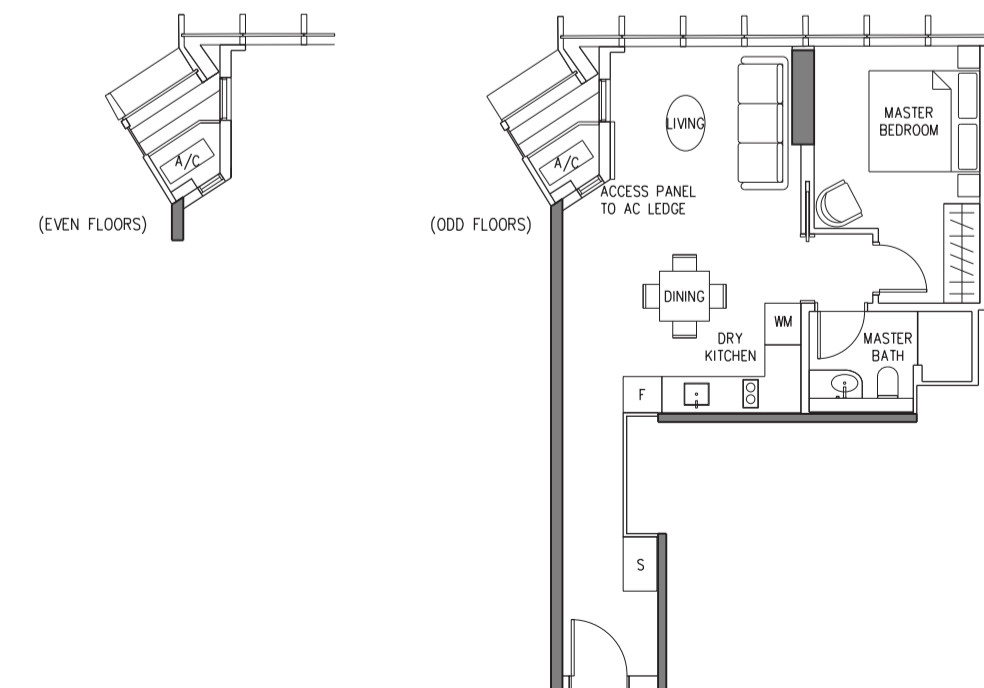
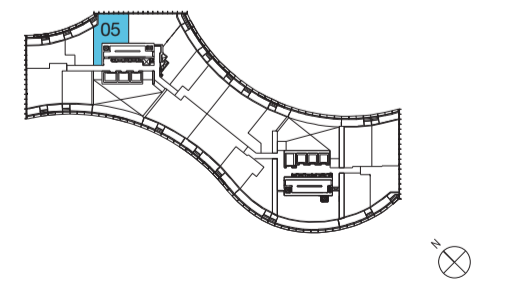

1-Bedroom

Type B4M / B4

67 sq.m. / 721 sq.ft.
Including 9 sq.m. / 97 sq.ft. of Balcony

#03-09 to #30-09

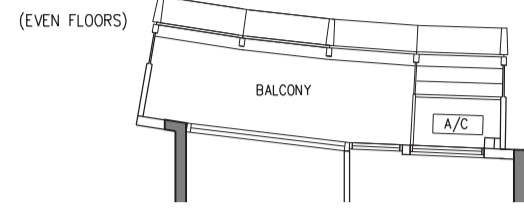
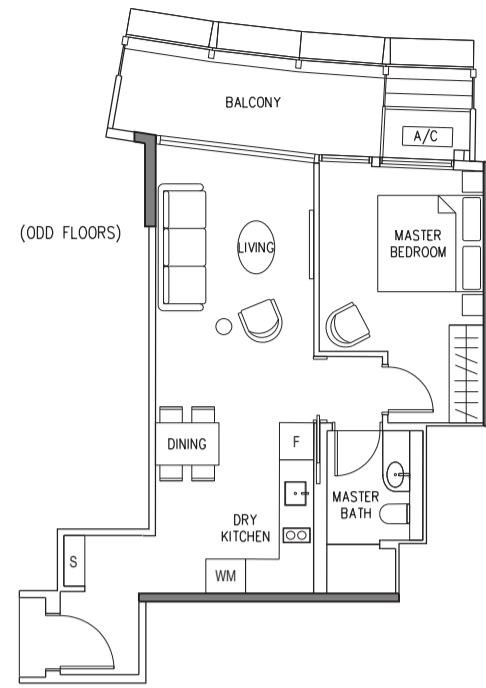
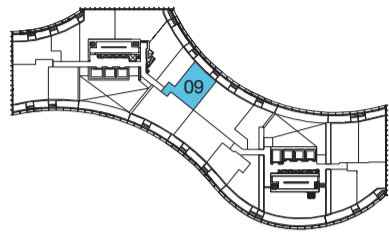

1-Bedroom

Type B7M / B7

62 sq.m. / 667 sq.ft.
Including 12 sq.m. / 129 sq.ft. of Balcony / Private Terrace

#03-20 (B7M)
#04-20 to #30-20 (B7)

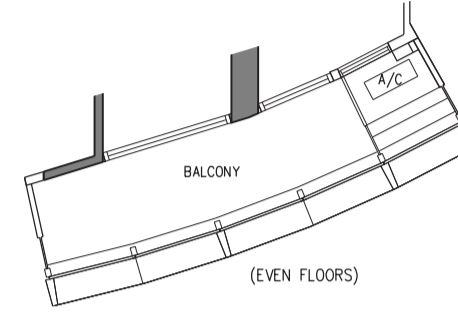
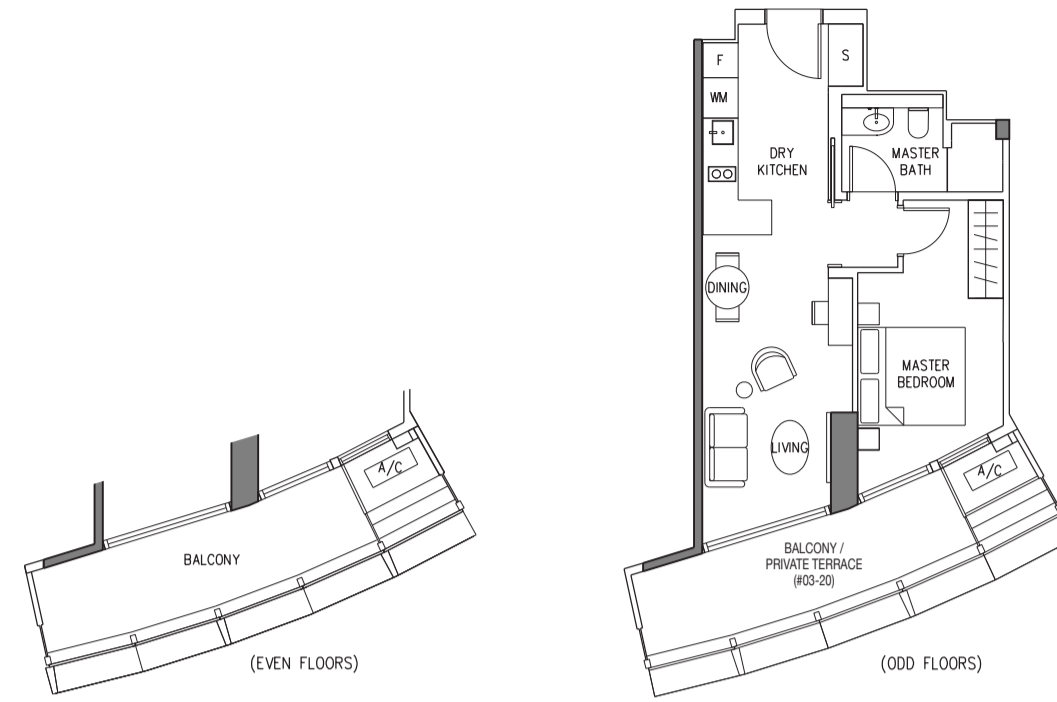
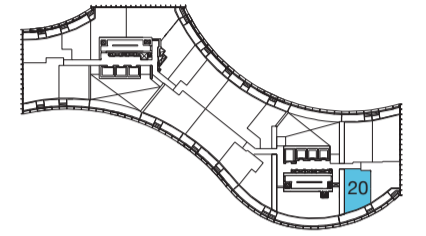

Type B5

57 sq.m. / 614 sq.ft.
Including 9 sq.m. / 97 sq.ft. of Balcony

#03-17 to #19-17

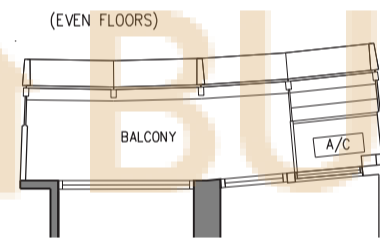
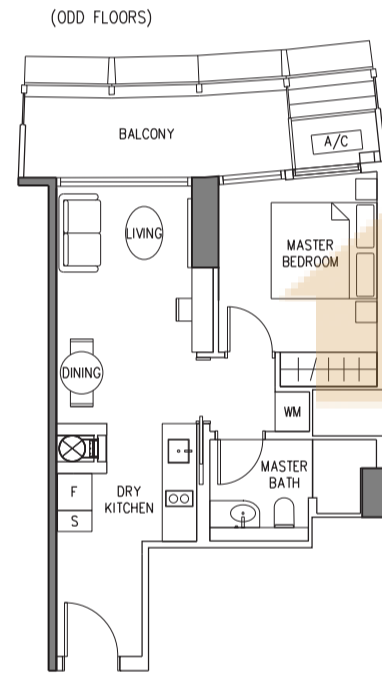
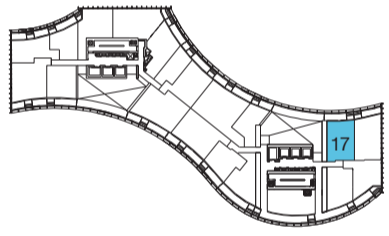

Type B8M

69 sq.m. / 743 sq.ft.
Including 18 sq.m. / 194 sq.ft. of Private Terrace

#03-12

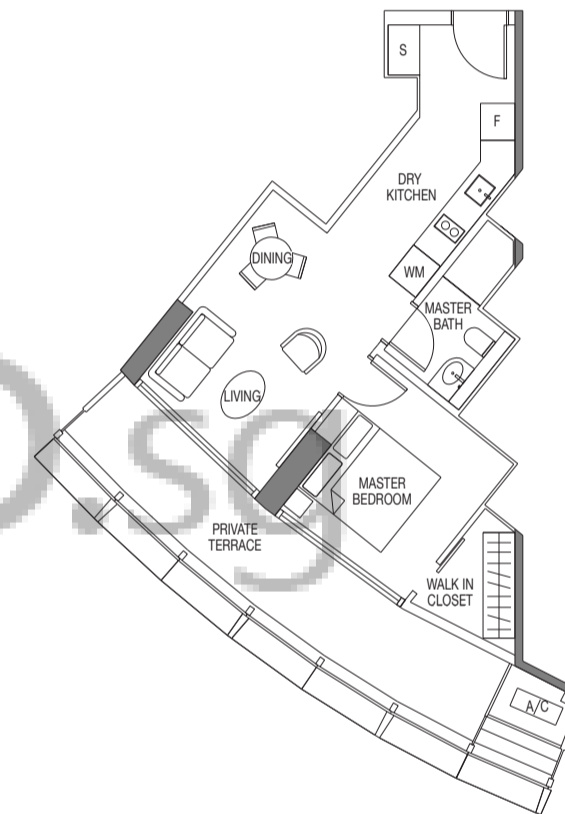
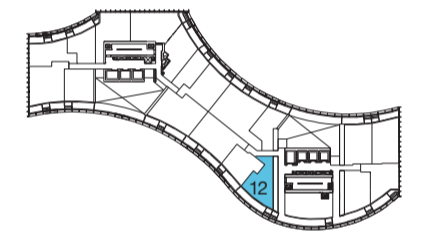

Type B6

64 sq.m. / 689 sq.ft.
Including 9 sq.m. / 97 sq.ft. of Balcony

#03-19 to #19-19

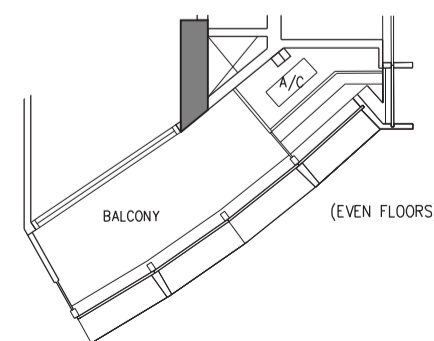
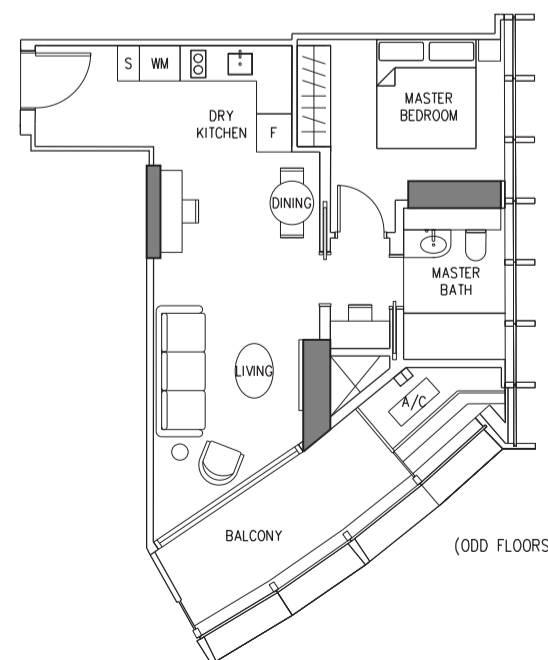
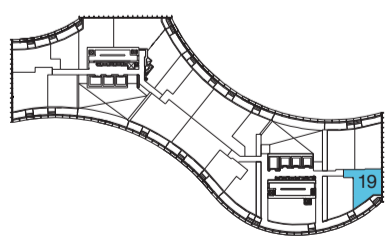

Type B8

66 sq.m. / 710 sq.ft.
Including 15 sq.m. / 161 sq.ft. of Balcony

#04-12 to #19-12

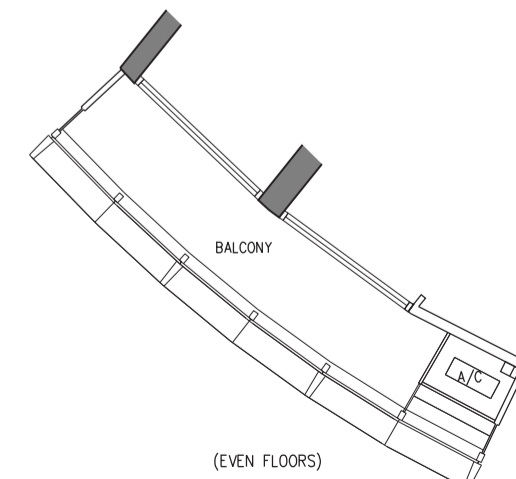
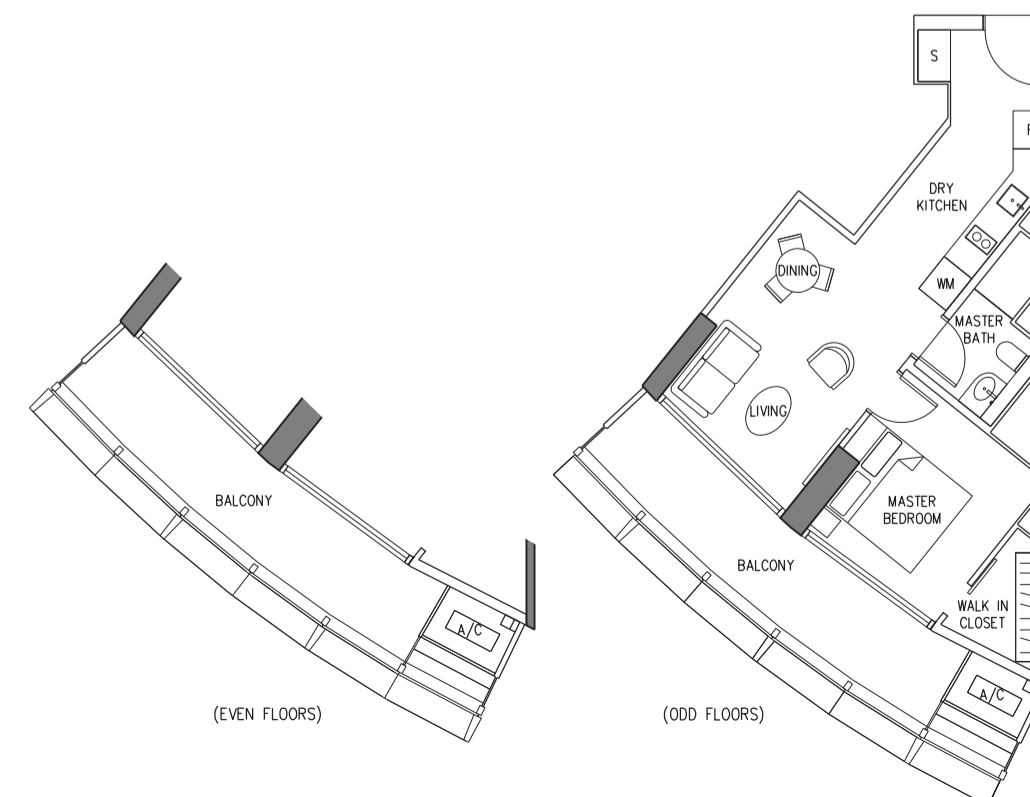
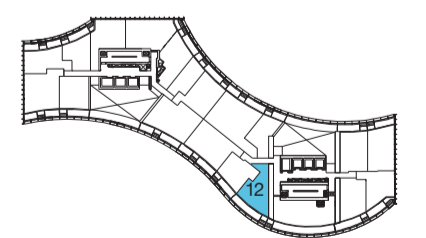

Type B9M / B9

55 sq.m. / 592 sq.ft.
Including 9 sq.m. / 97 sq.ft. of Balcony

#03-13 to #04-13 (B9M)
#05-13 to #30-13 (B9)

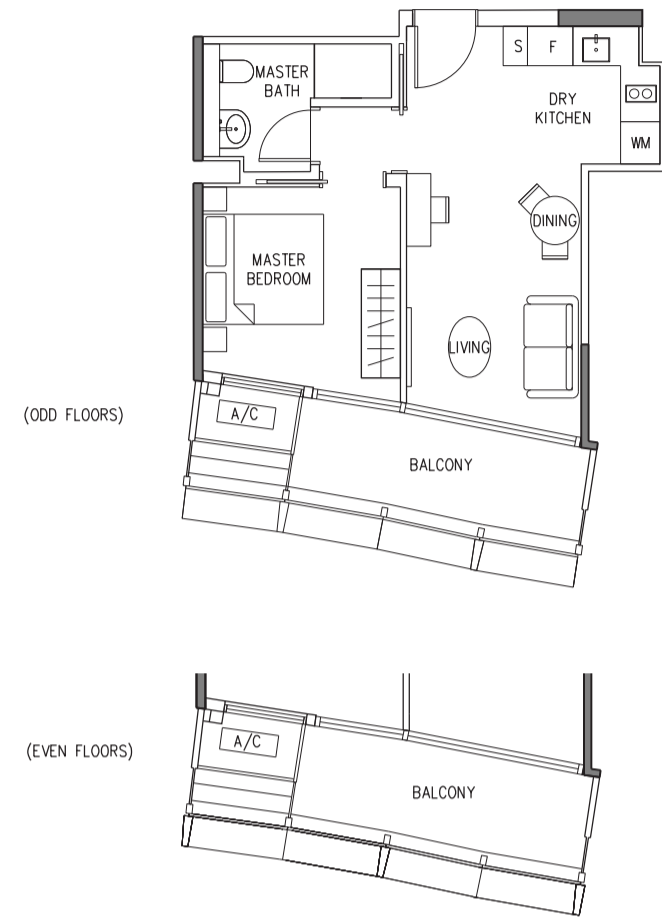
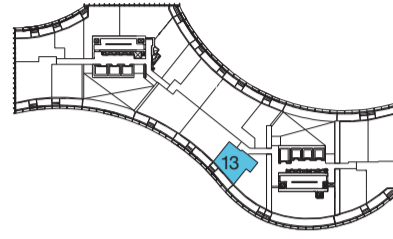

Type B11

68 sq.m. / 732 sq.ft.
Including 9 sq.m. / 97 sq.ft. of Balcony

#22-12 to #30-12

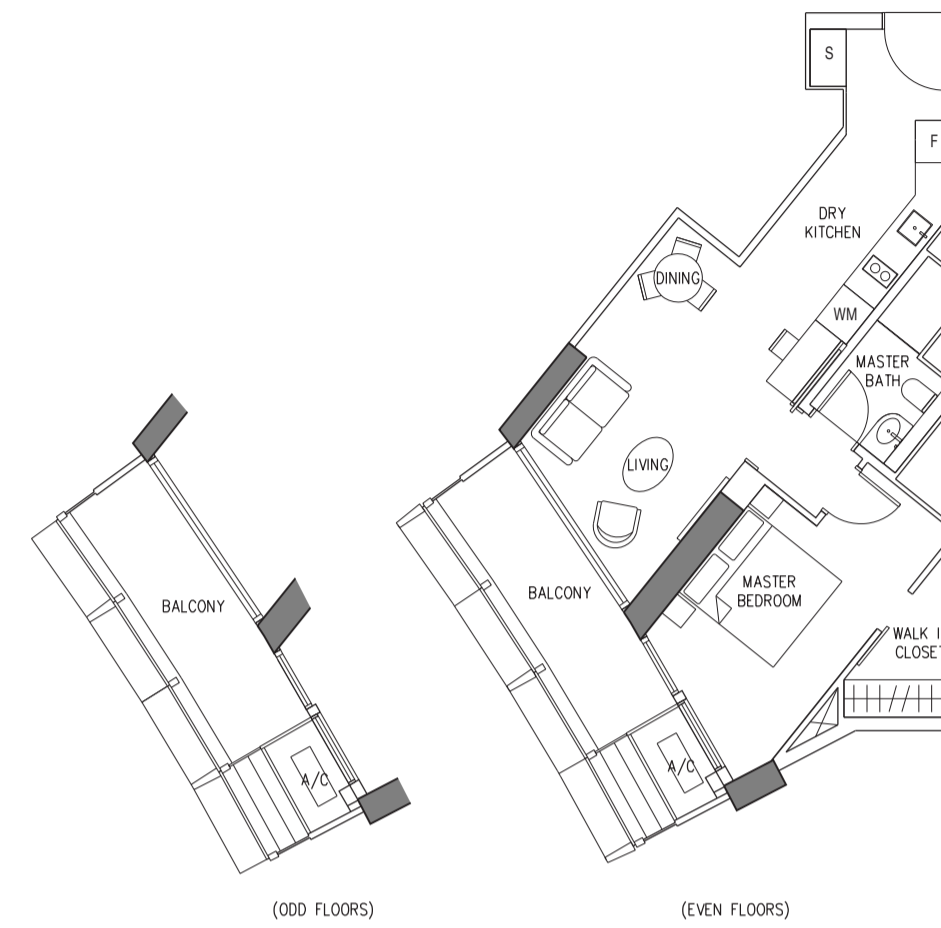
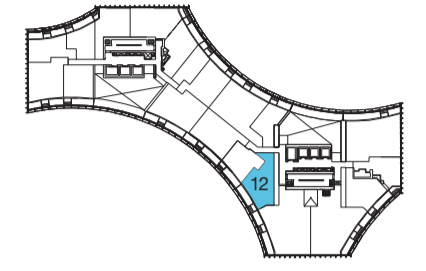

Type B10

52 sq.m. / 560 sq.ft.

#22-18 to #30-18

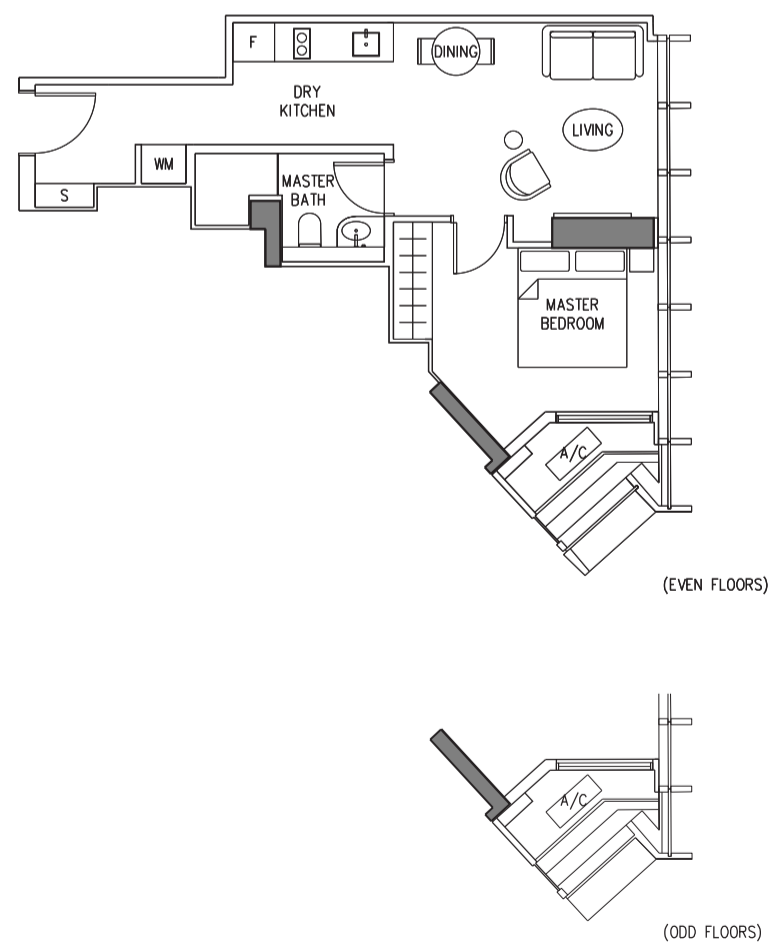
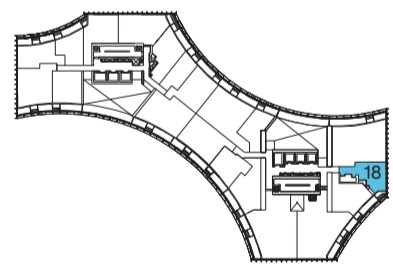

Type B12

55 sq.m. / 592 sq.ft.
Including 9 sq.m. / 97 sq.ft. of Balcony

#22-13 to #30-13

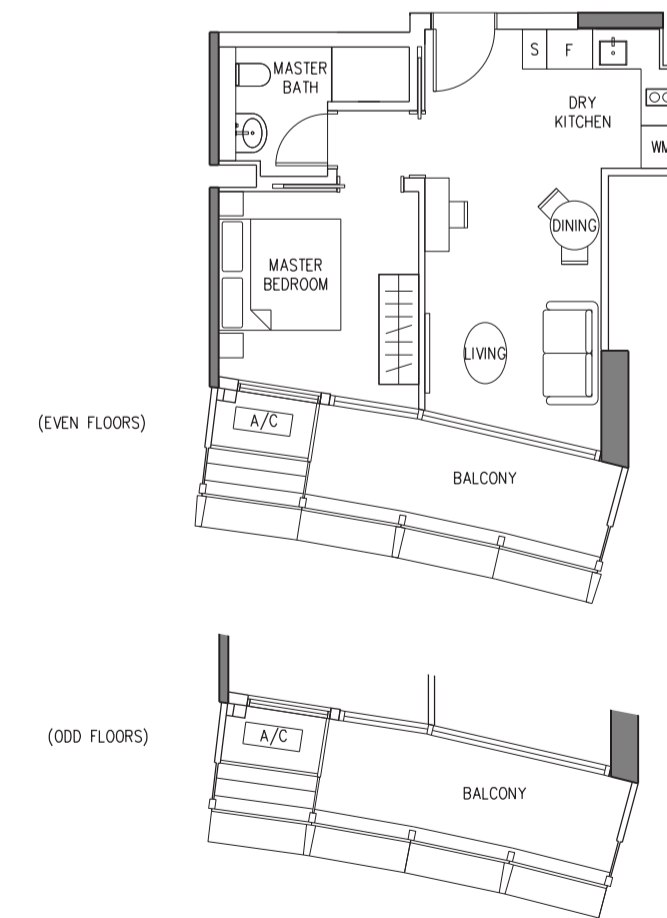
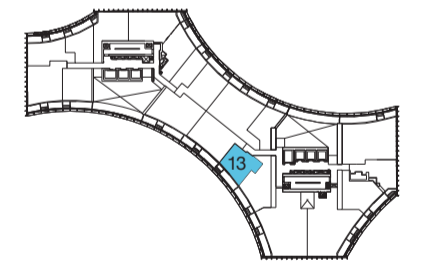

Type C1M / C1

64 sq.m. / 689 sq.ft.
Including 13 sq.m. / 140 sq.ft. of Balcony

#03-03 to #04-03 (C1M)
#05-03 to #30-03 (C1)

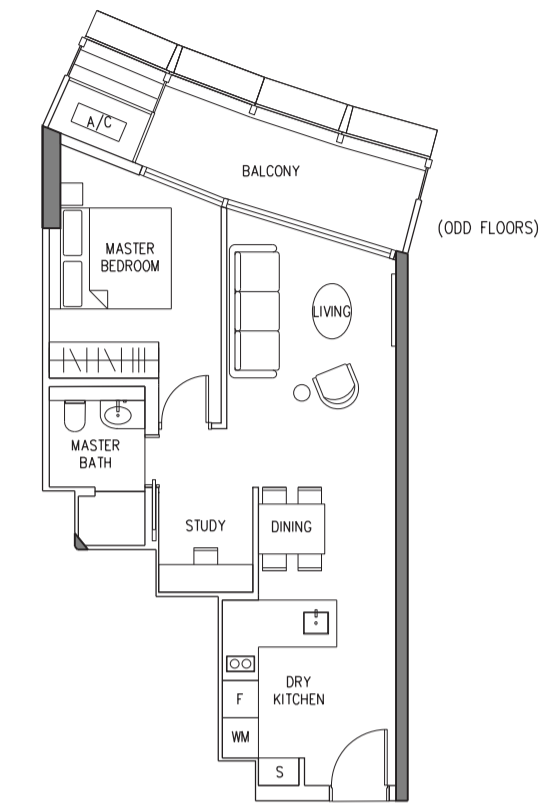
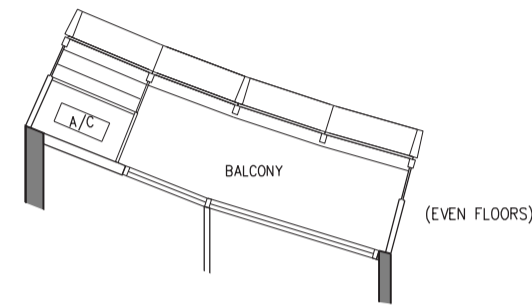
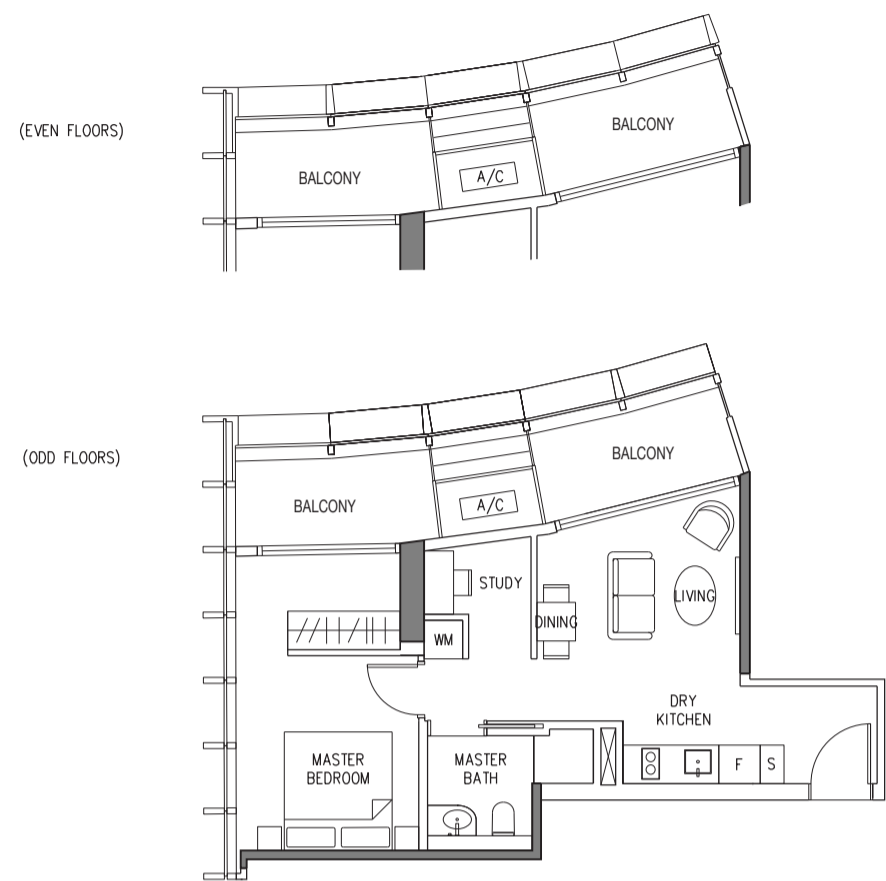
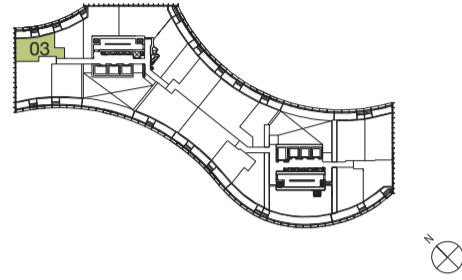

Type C2

67 sq.m. / 721 sq.ft.
Including 9 sq.m. / 97 sq.ft. of Balcony

#05-07 to #30-07

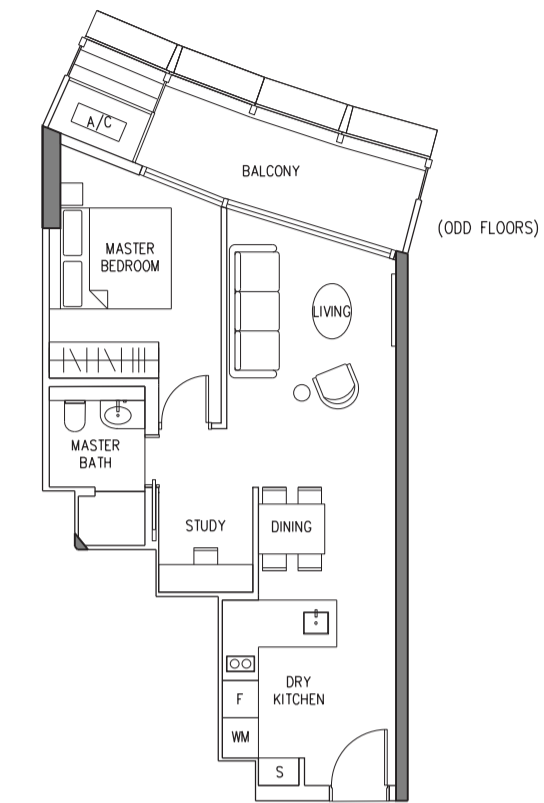
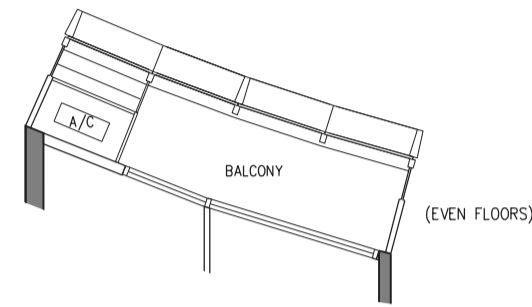
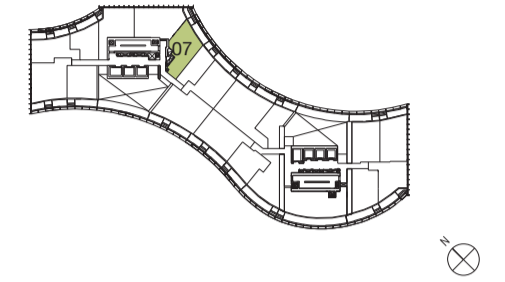

Type C2M

66 sq.m. / 710 sq.ft.
Including 9 sq.m. / 97 sq.ft. of Balcony

#03-07 to #04-07

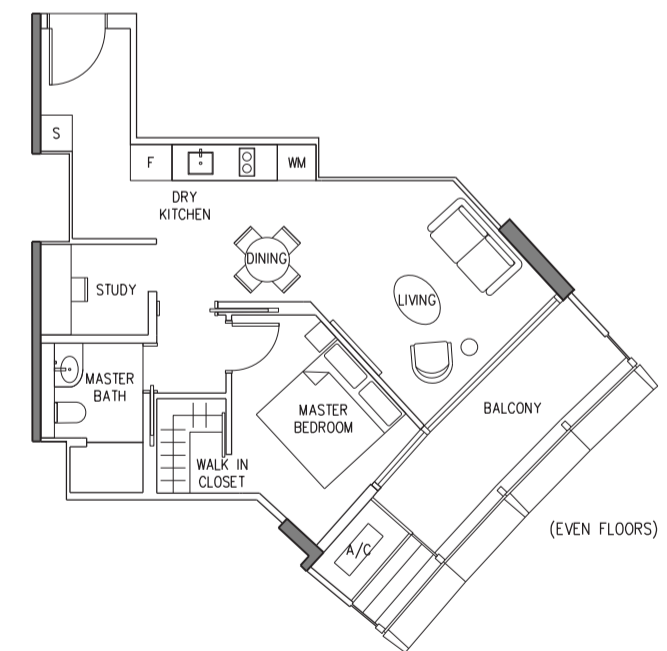
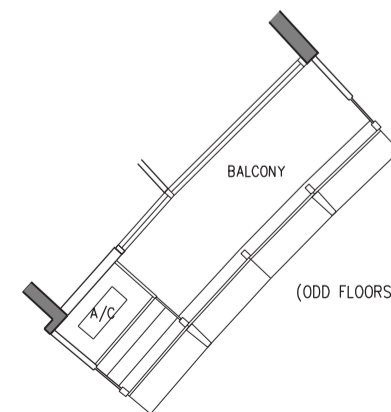
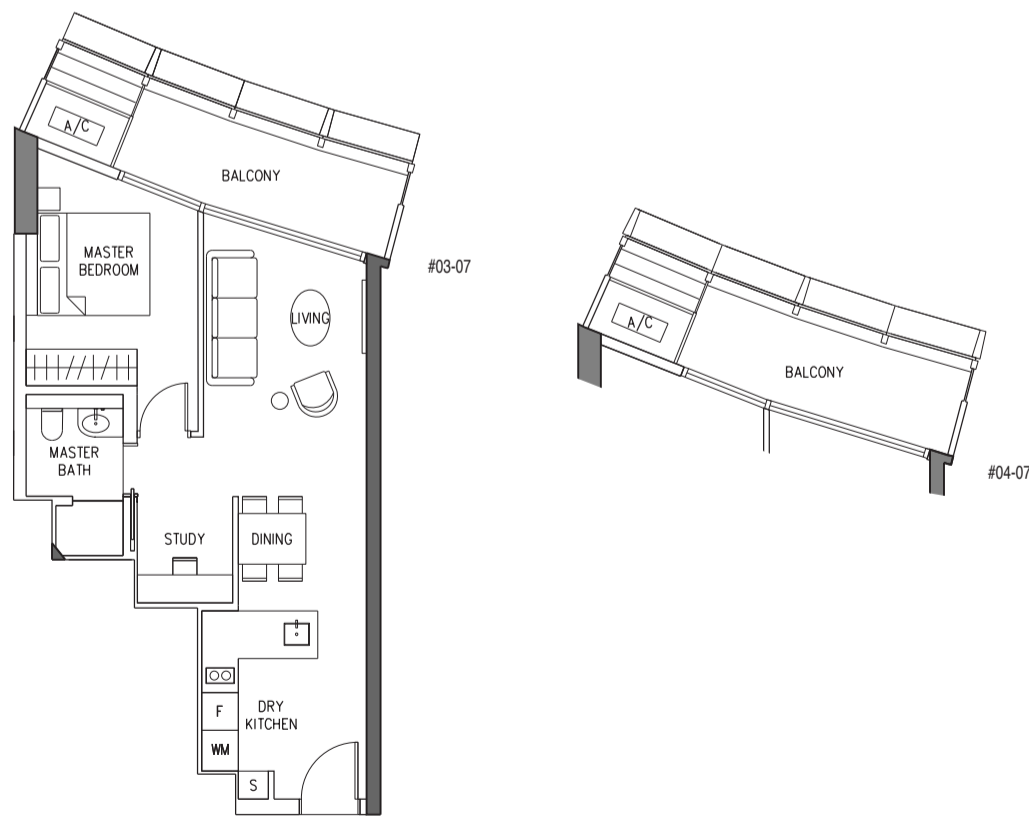
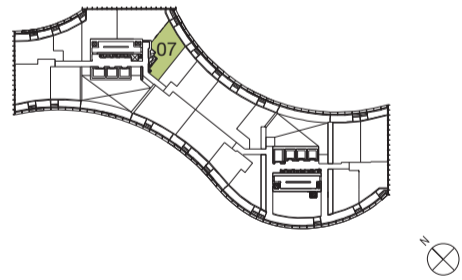

Type C3

65 sq.m. / 700 sq.ft.
Including 9 sq.m. / 97 sq.ft. of Balcony

#22-19 to #30-19

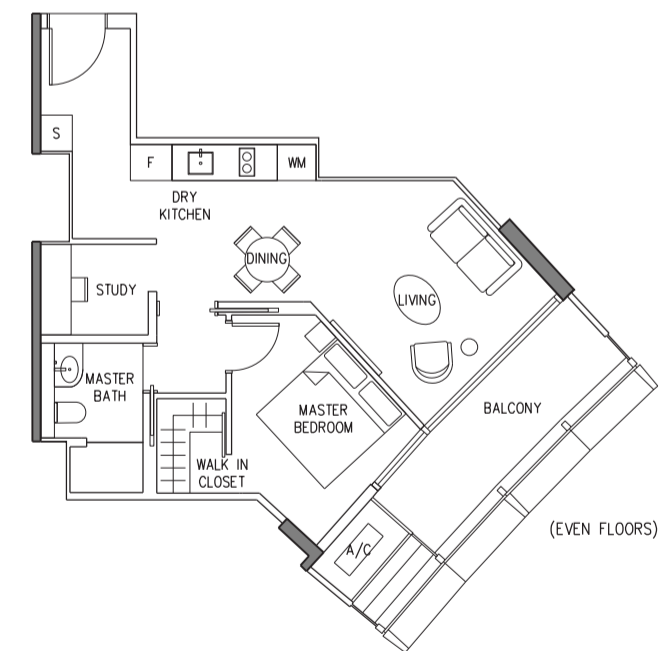
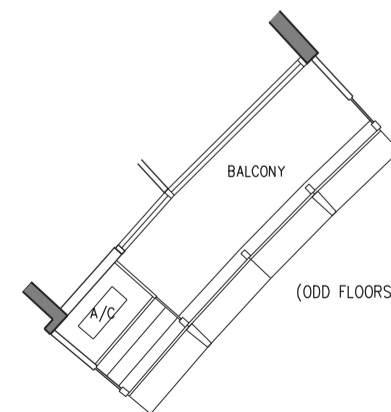
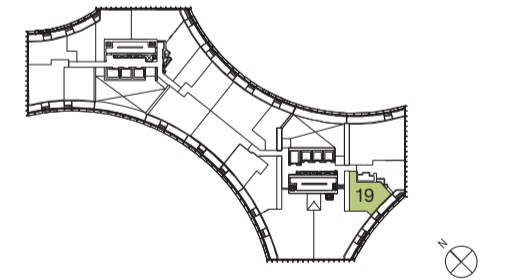

Type D1M

95 sq.m. / 1,023 sq.ft.
Including 15 sq.m. / 161 sq.ft. of Balcony

#03-10 to #04-10

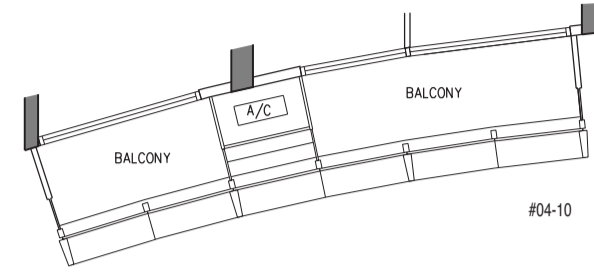
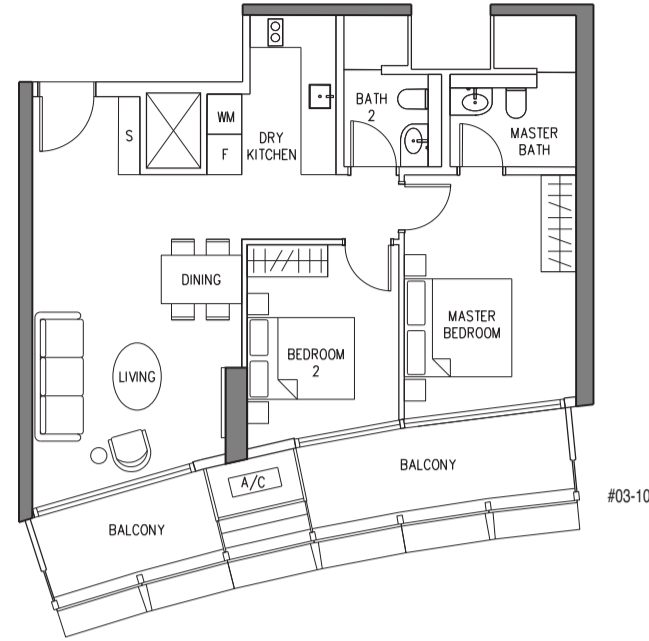
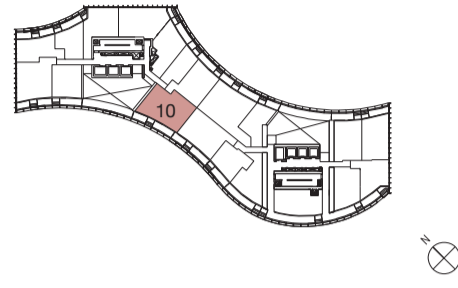

#04-10

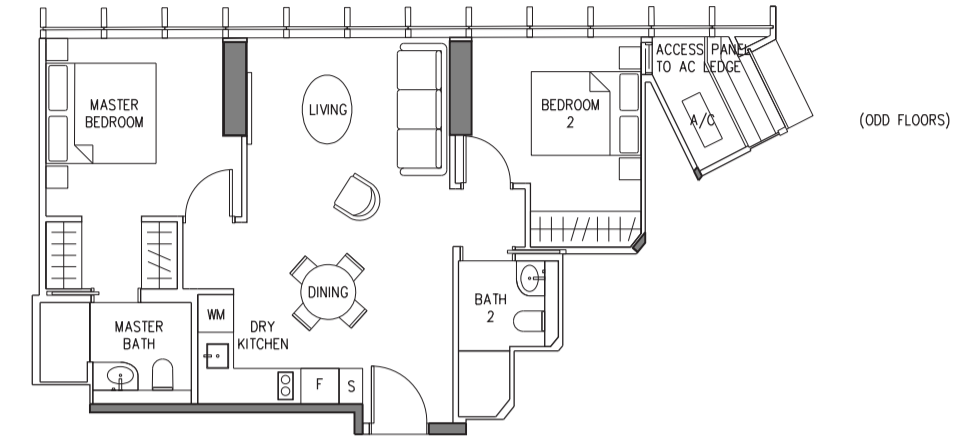

(ODD FLOORS)

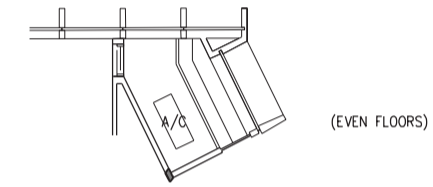

(EVEN FLOORS)

Type D3

76 sq.m. / 818 sq.ft.

#03-06 to #30-06

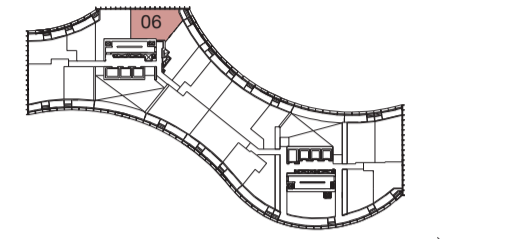

Type D1

94 sq.m. / 1,012 sq.ft.
Including 15 sq.m. / 161 sq.ft. of Balcony

#05-10 to #30-10

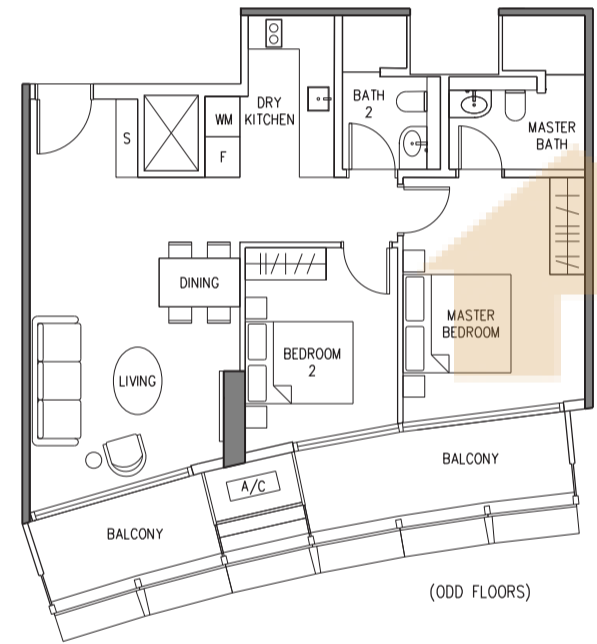
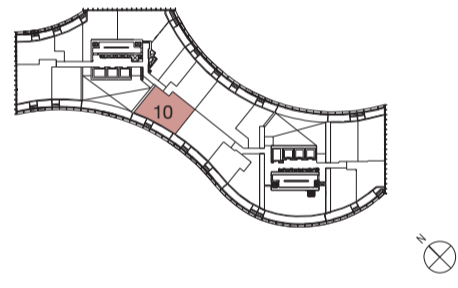

(ODD FLOORS)

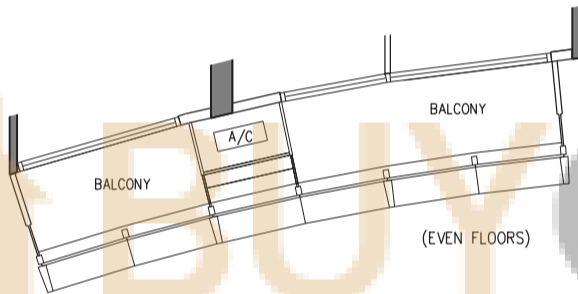

(EVEN FLOORS)

Type D4

78 sq.m. / 840 sq.ft.
Including 8 sq.m. / 86 sq.ft. of Balcony

#03-18 to #19-18

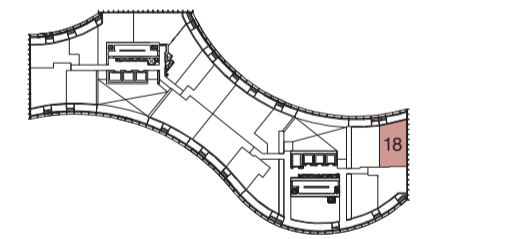

Type D2M / D2

87 sq.m. / 936 sq.ft.
Including 12 sq.m. / 129 sq.ft. of Balcony

#03-02 to #04-02 (D2M)

#05-02 to #30-02 (D2)

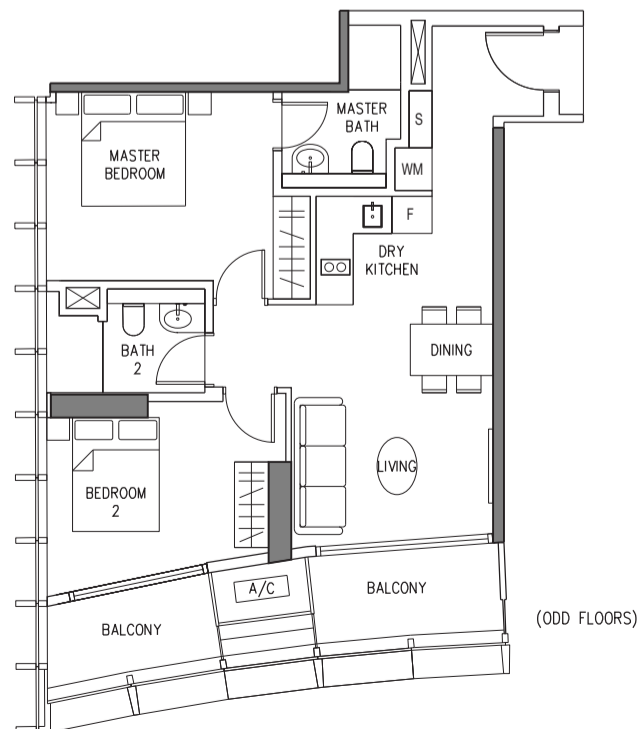
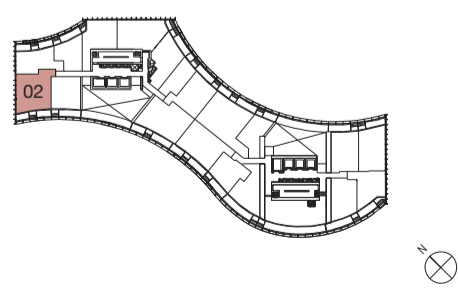

(ODD FLOORS)

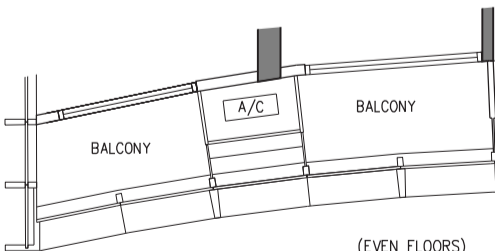

(EVEN FLOORS)

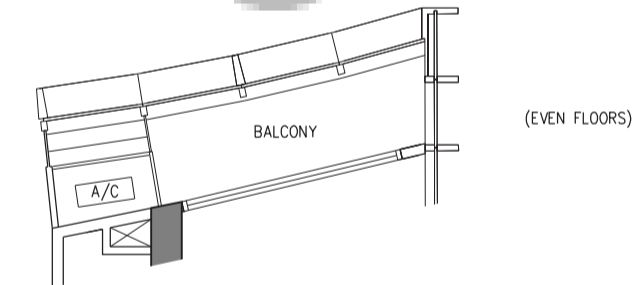

(EVEN FLOORS)

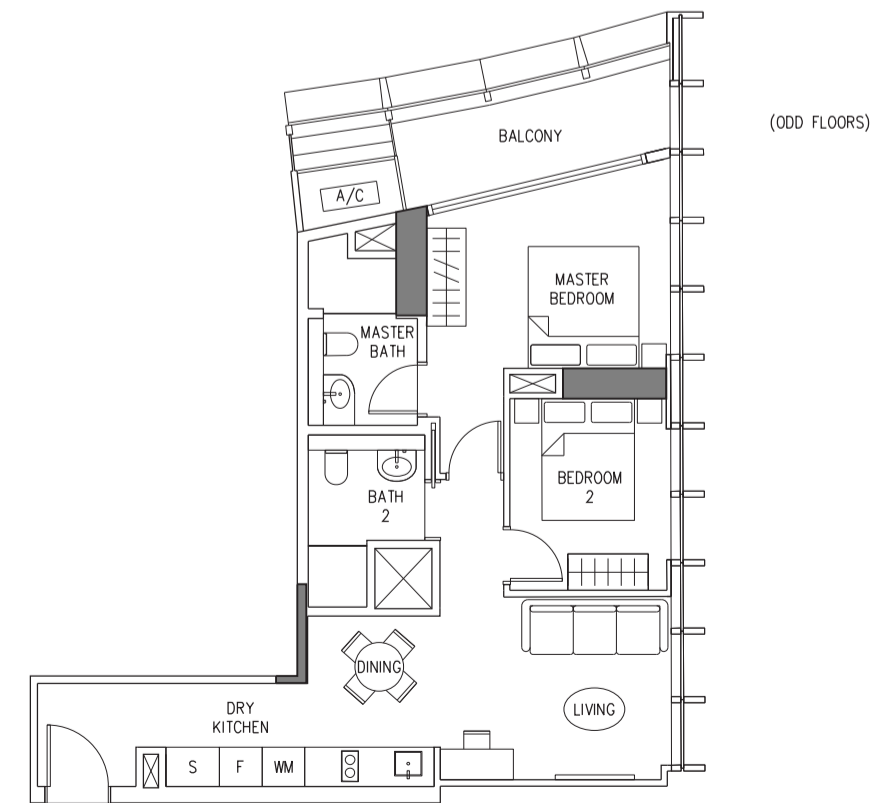

(ODD FLOORS)

Type D5M

91 sq.m. / 980 sq.ft.
Including 15 sq.m. / 161 sq.ft. of Balcony

#03-14 to #04-14

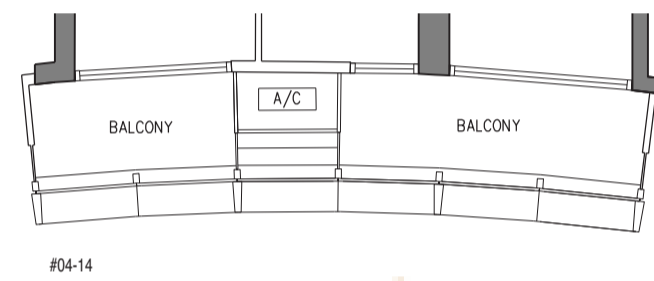
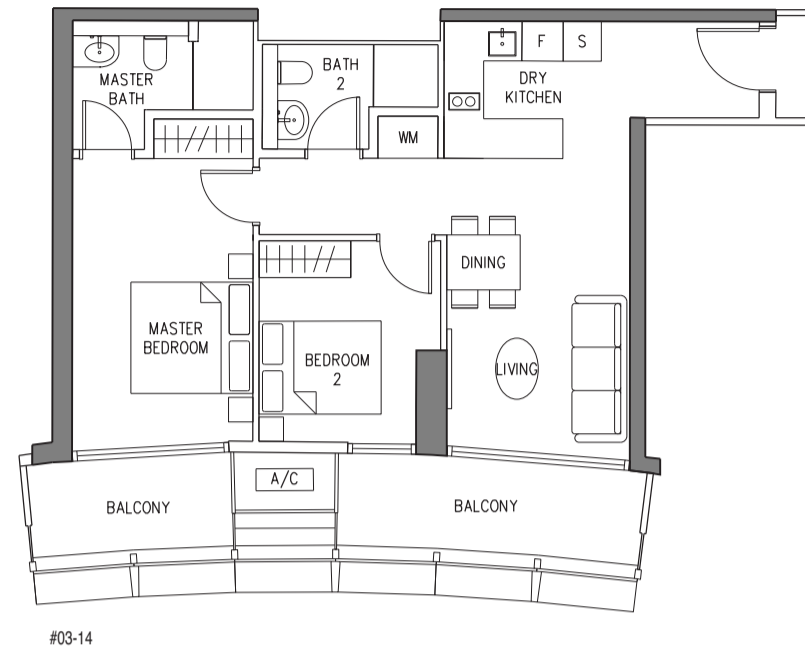
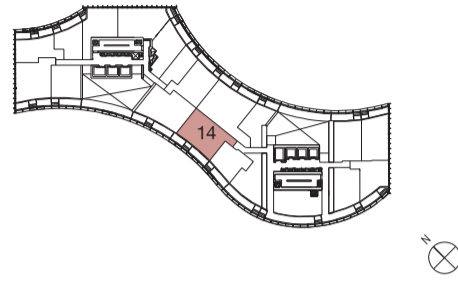

Type D6

95 sq.m. / 1,023 sq.ft.
Including 15 sq.m. / 161 sq.ft. of Balcony

#32-13 to #47-13

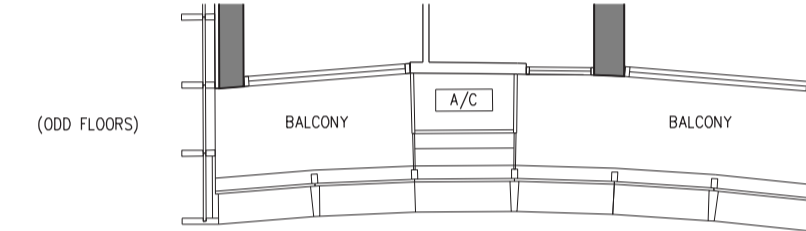
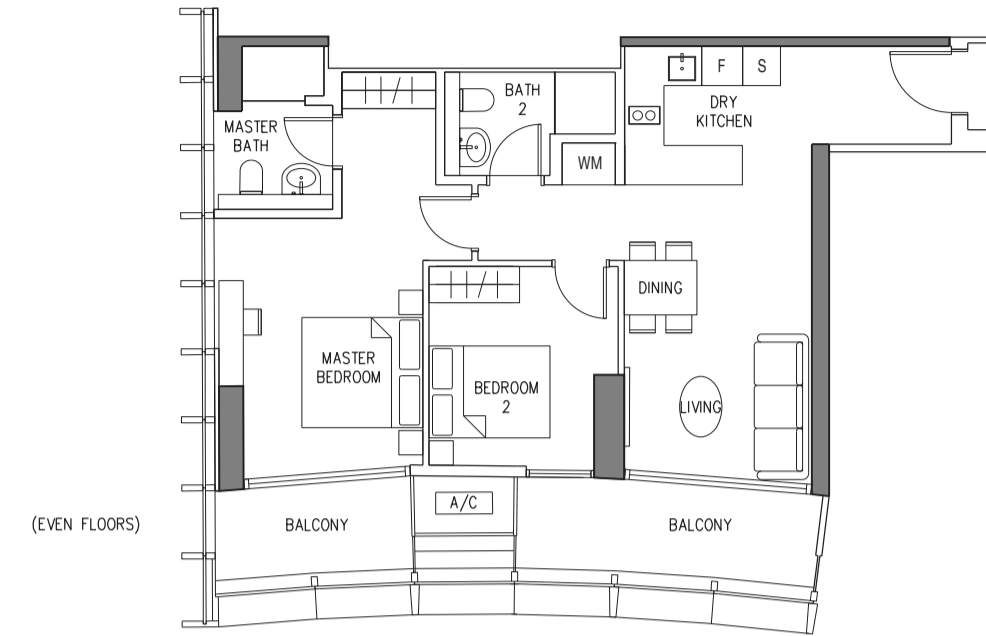
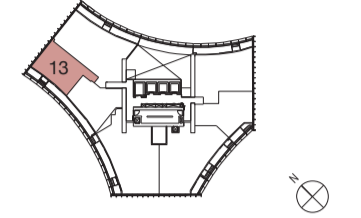

Type D5

90 sq.m. / 969 sq.ft.
Including 15 sq.m. / 161 sq.ft. of Balcony

#05-14 to #30-14

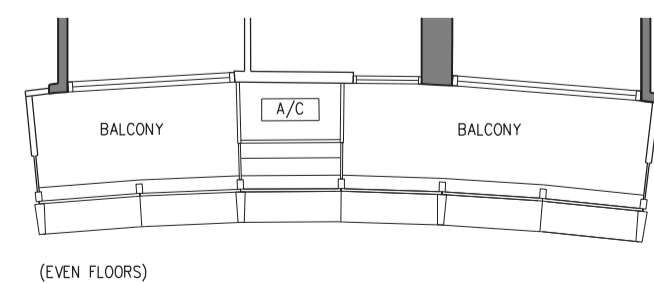
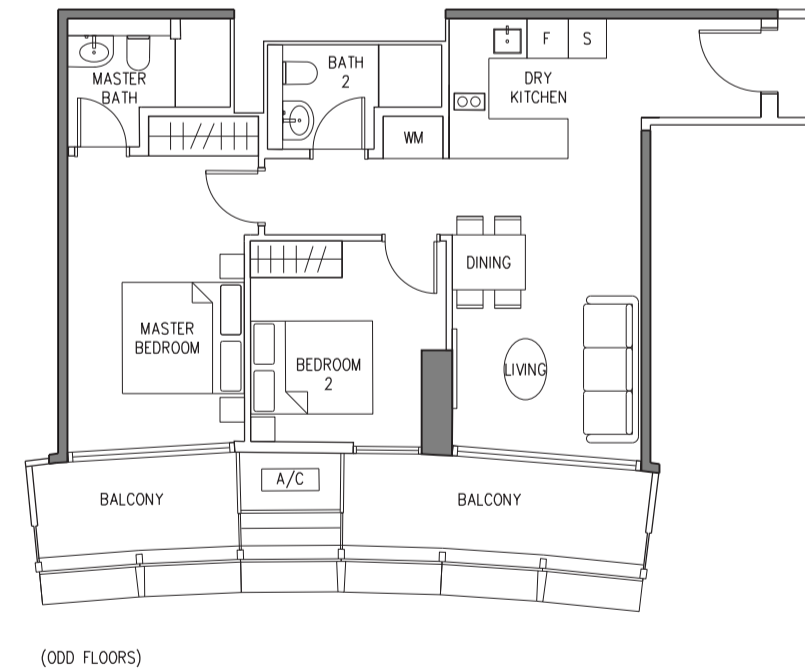
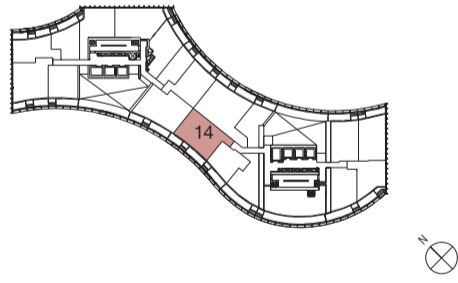

Type D7

76 sq.m. / 818 sq.ft.
Including 18 sq.m. / 194 sq.ft. of Private Terrace

#03-11

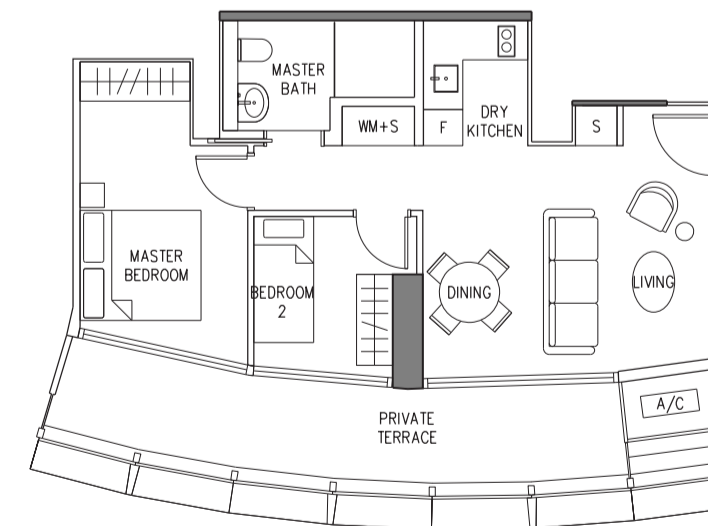
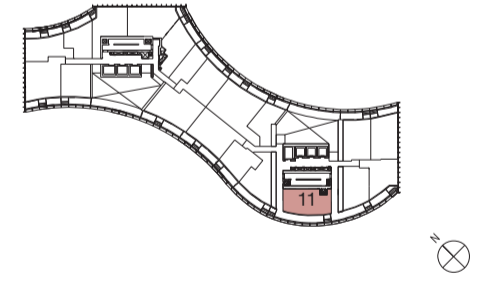

Type E1M / E1

103 sq.m. / 1,109 sq.ft.
Including 15 sq.m. / 161 sq.ft. of Balcony

#03-15 to #04-15 (E1M)
#05-15 to #30-15 (E1)

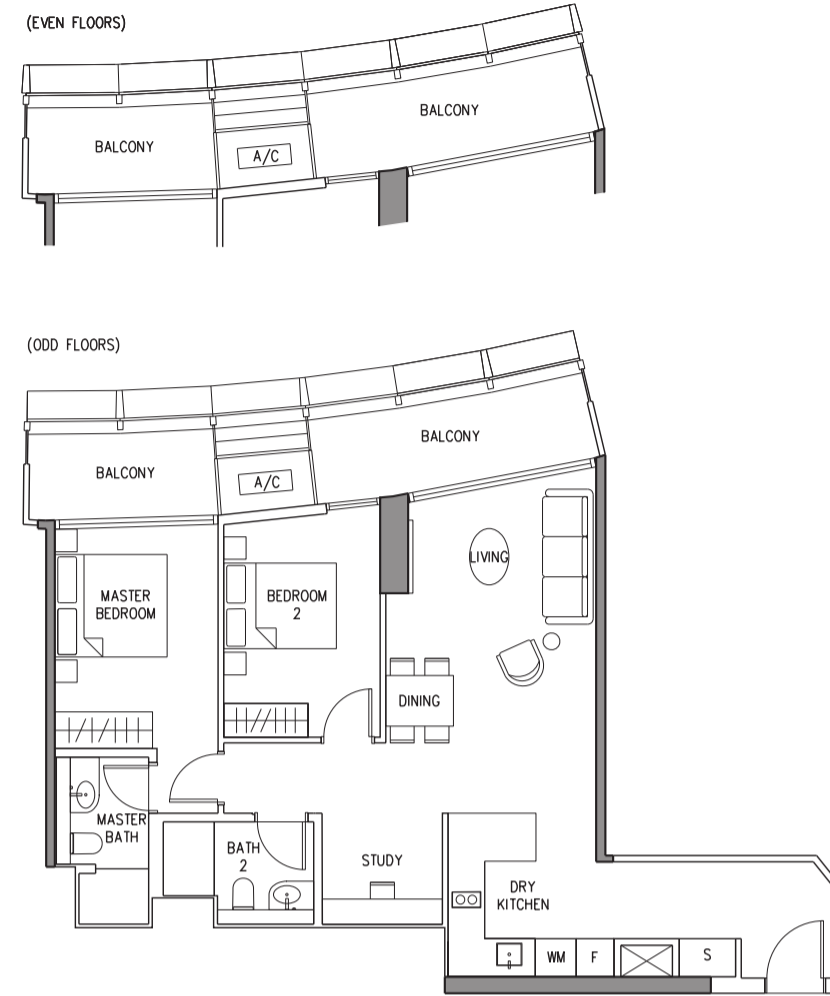
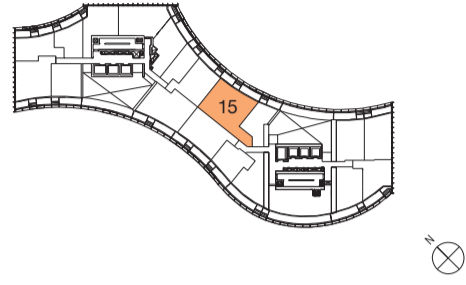

Type E3

88 sq.m. / 947 sq.ft.
Including 6 sq.m. / 65 sq.ft. of Balcony

#32-19 to #47-19

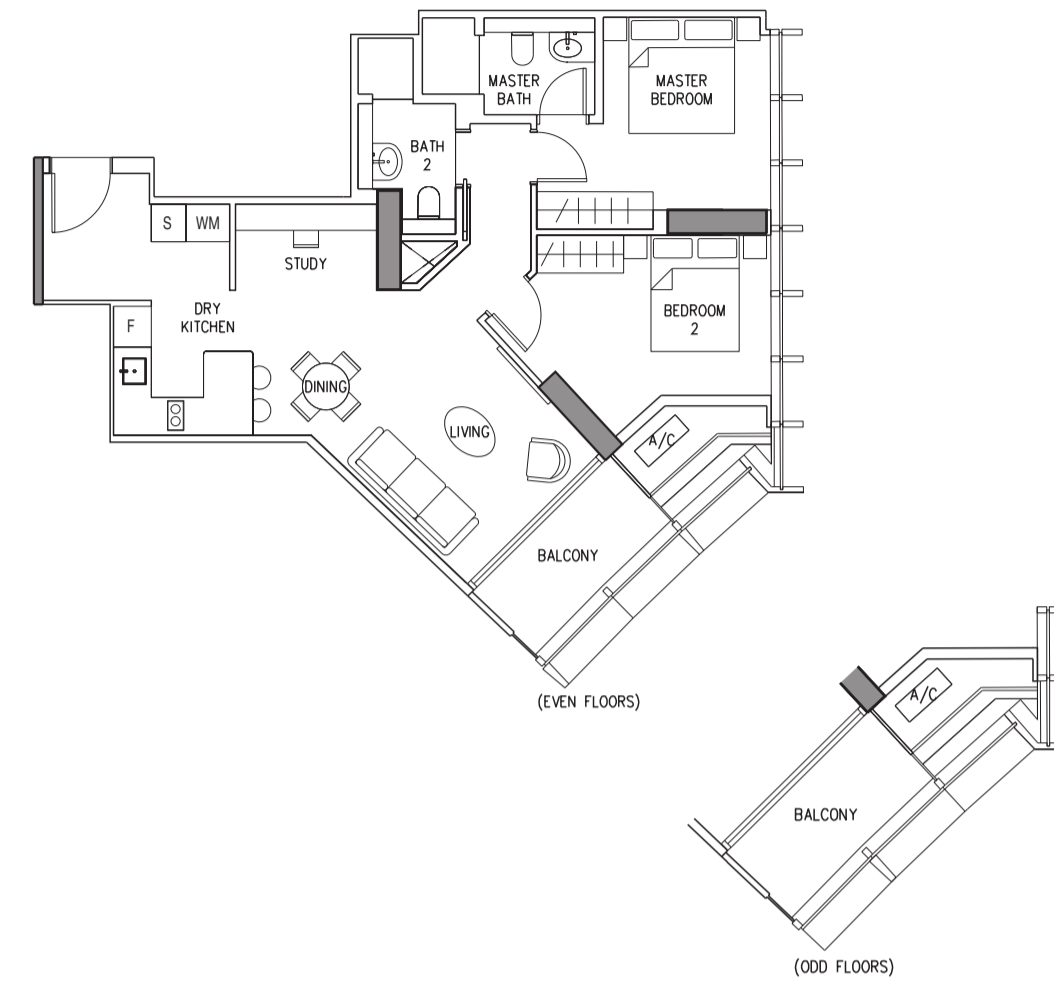
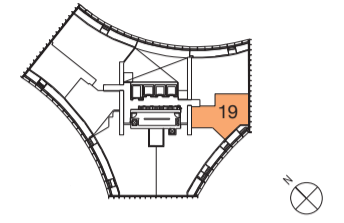

Type E2

110 sq.m. / 1,184 sq.ft.
Including 27 sq.m. / 291 sq.ft. of Balcony

#04-11 to #19-11

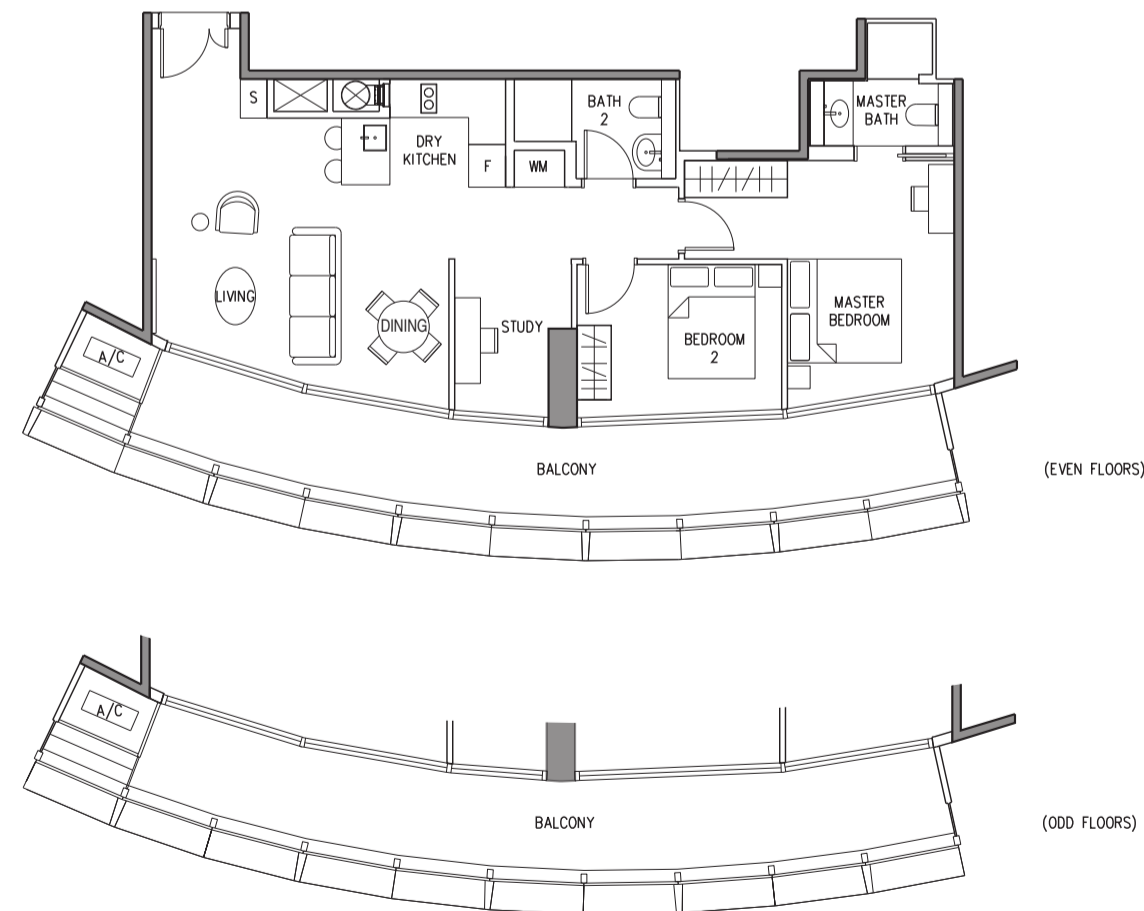
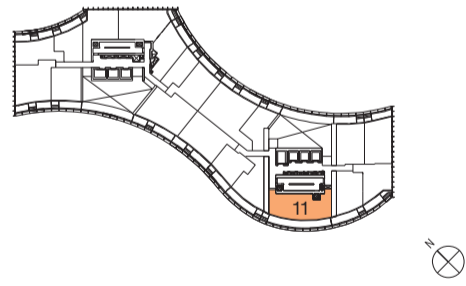

Type E4

93 sq.m. / 1,001 sq.ft.
Including 15 sq.m. / 161 sq.ft. of Balcony

#32-12 to #47-12

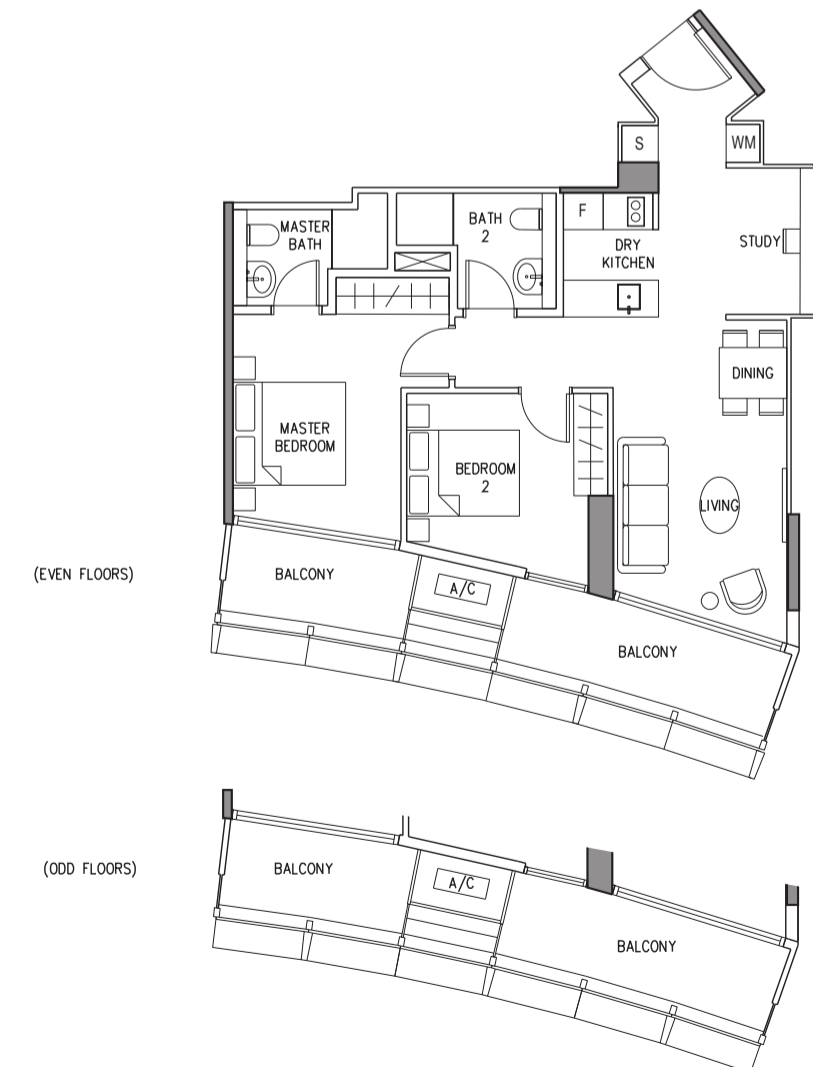
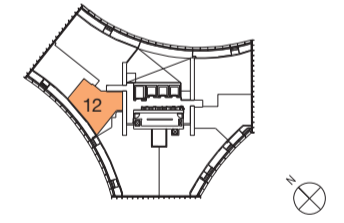

3-Bedroom

Type F1

160 sq.m. / 1,722 sq.ft.
Including 25 sq.m. / 269 sq.ft. of Balcony

#32-15 to #47-15

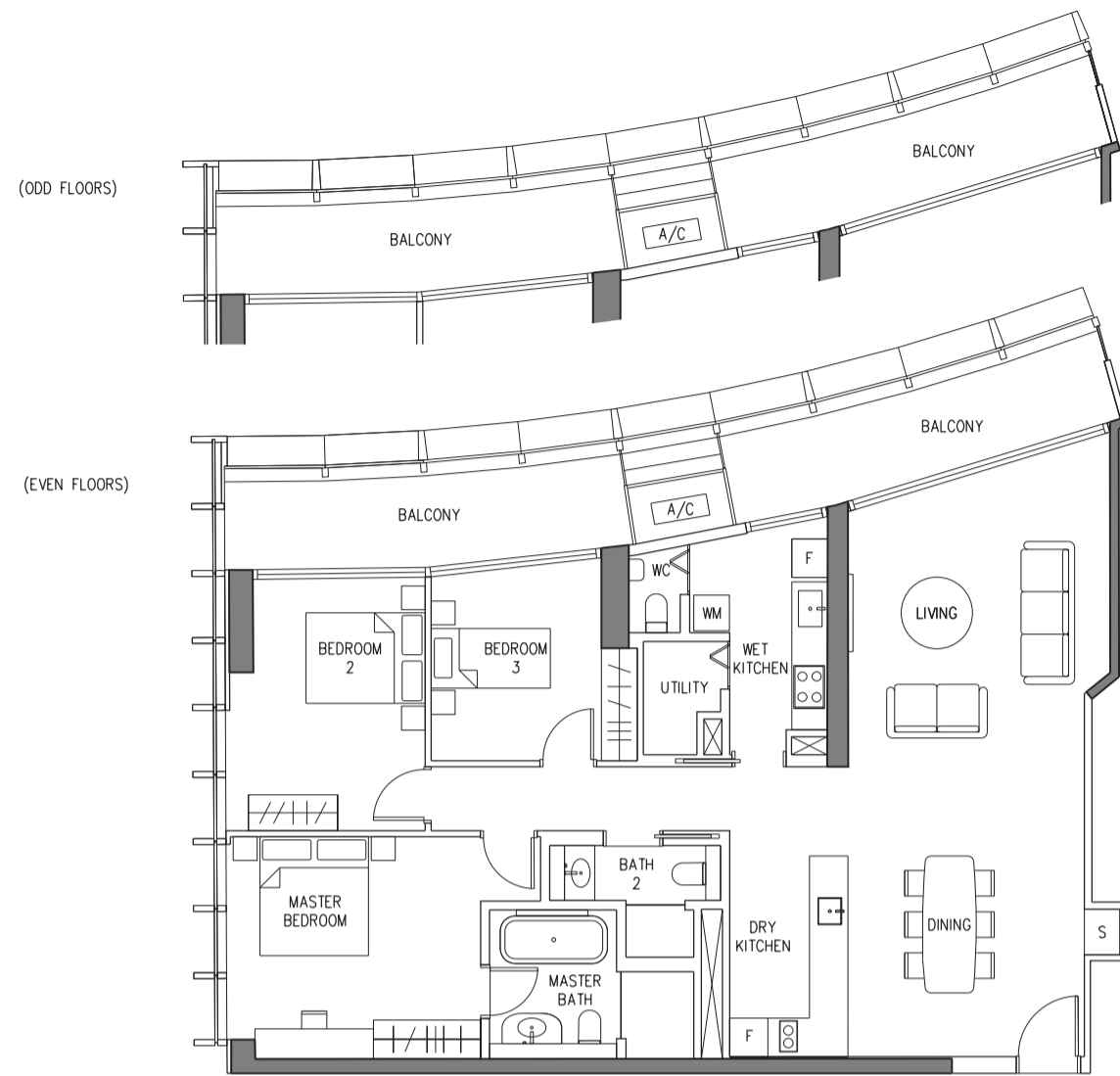
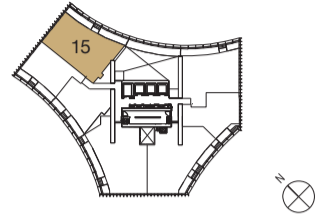

3-Bedroom

Type F3

142 sq.m. / 1,528 sq.ft.
Including 14 sq.m. / 151 sq.ft. of Balcony

#22-20 to #30-20

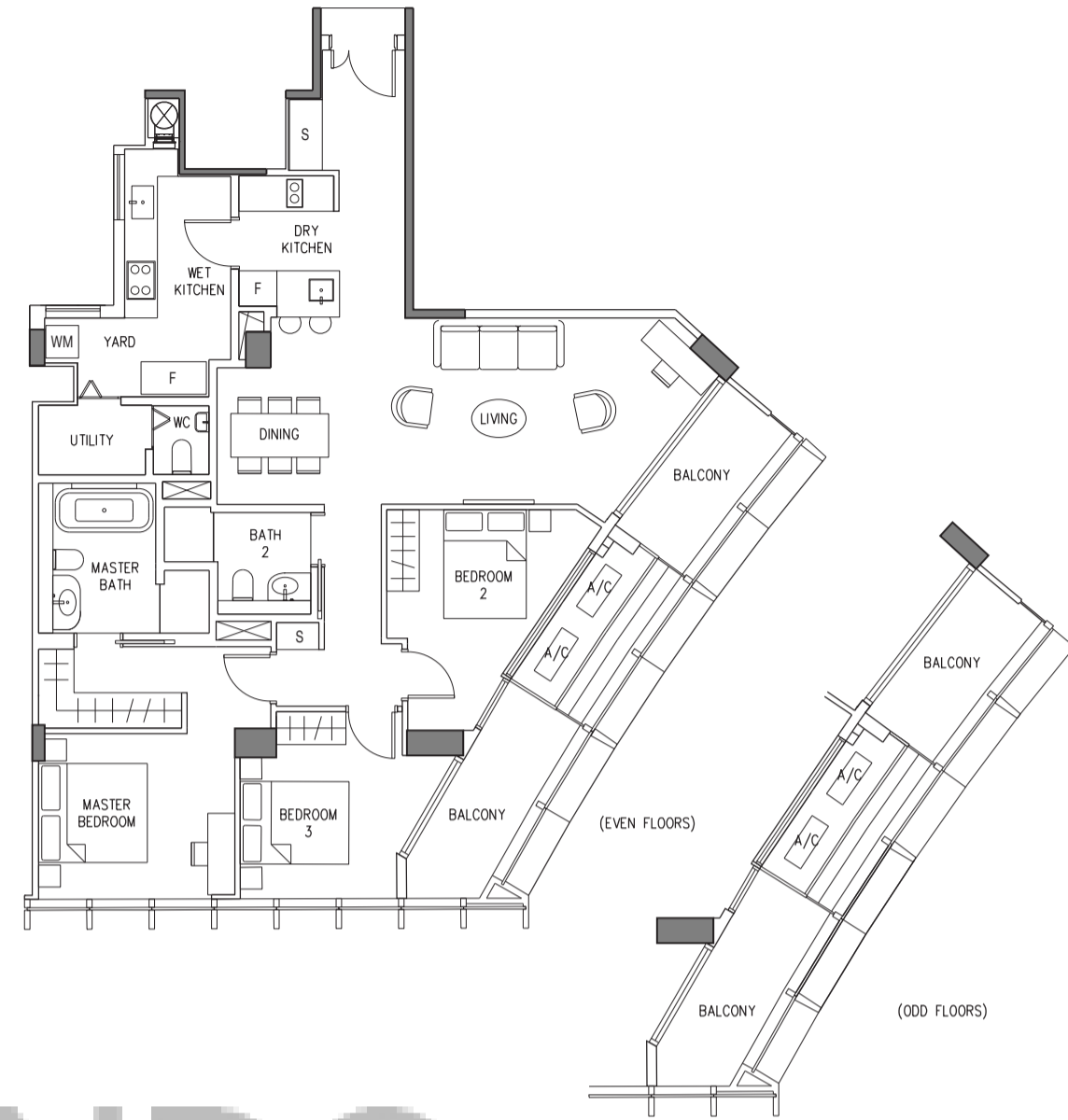
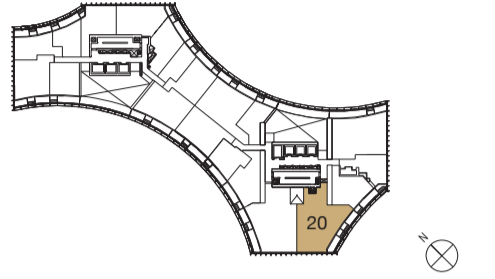

Type F2

133 sq.m. / 1,432 sq.ft.
Including 20 sq.m. / 215 sq.ft. of Balcony

#22-17 to #30-17

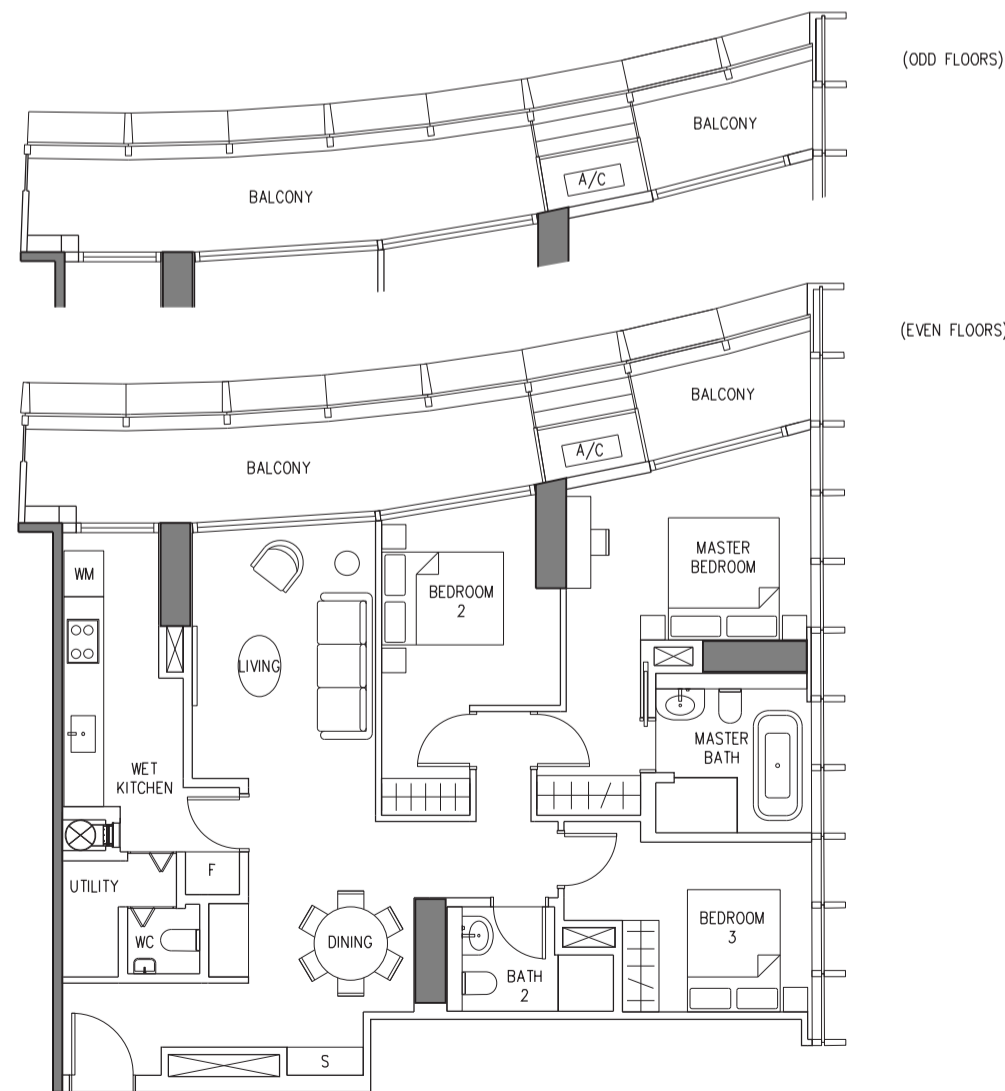
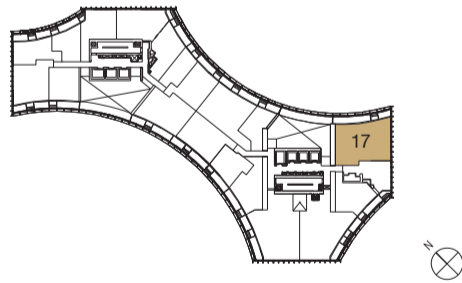

Type F4

150 sq.m. / 1,615 sq.ft.
Including 16 sq.m. / 172 sq.ft. of Balcony

#22-11 to #30-11

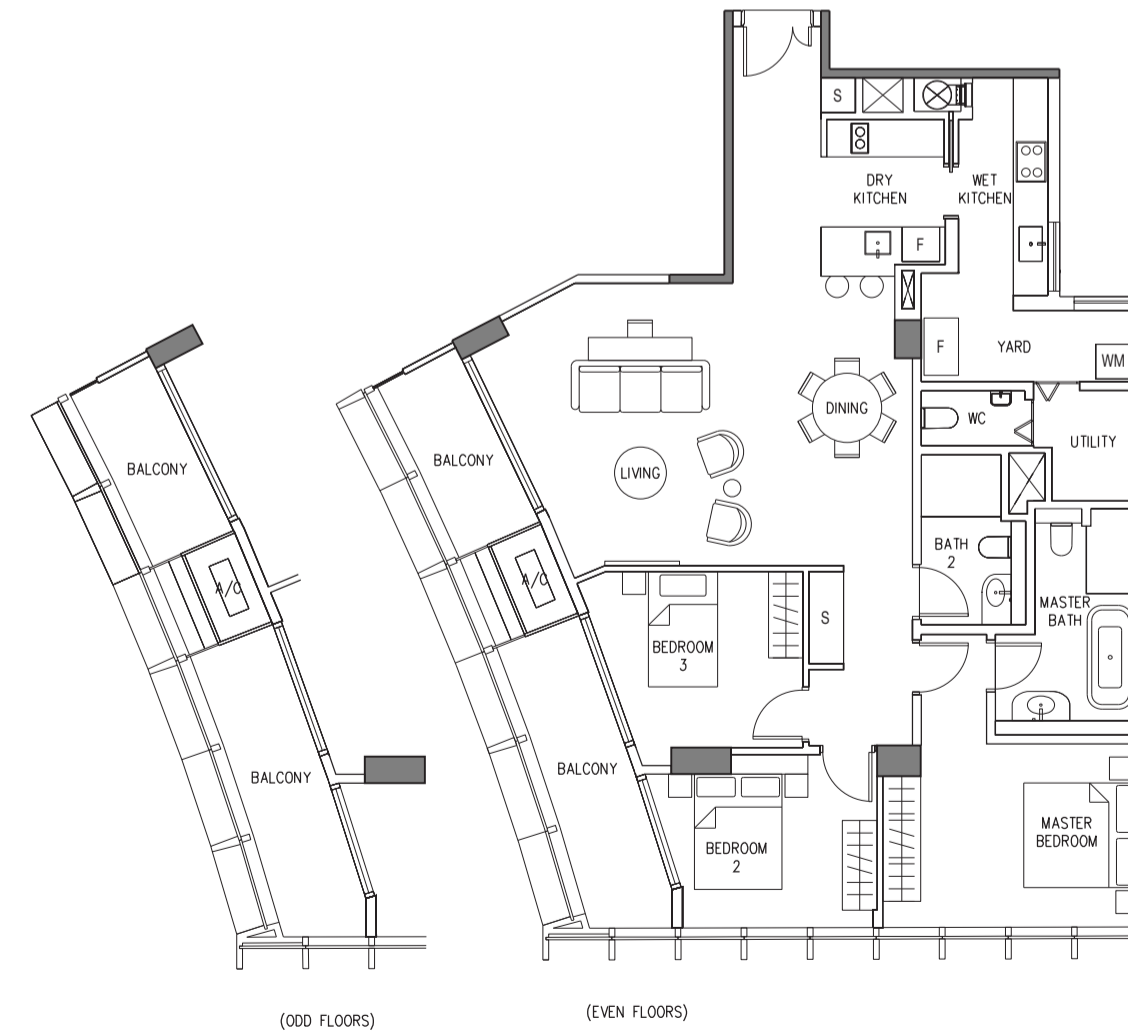
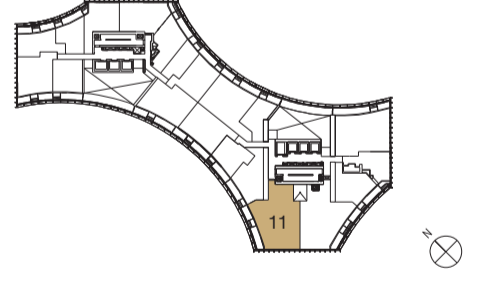

3-Bedroom

Type F5

142 sq.m. / 1,528 sq.ft.
Including 20 sq.m. / 215 sq.ft. of Balcony

#32-18 to #47-18

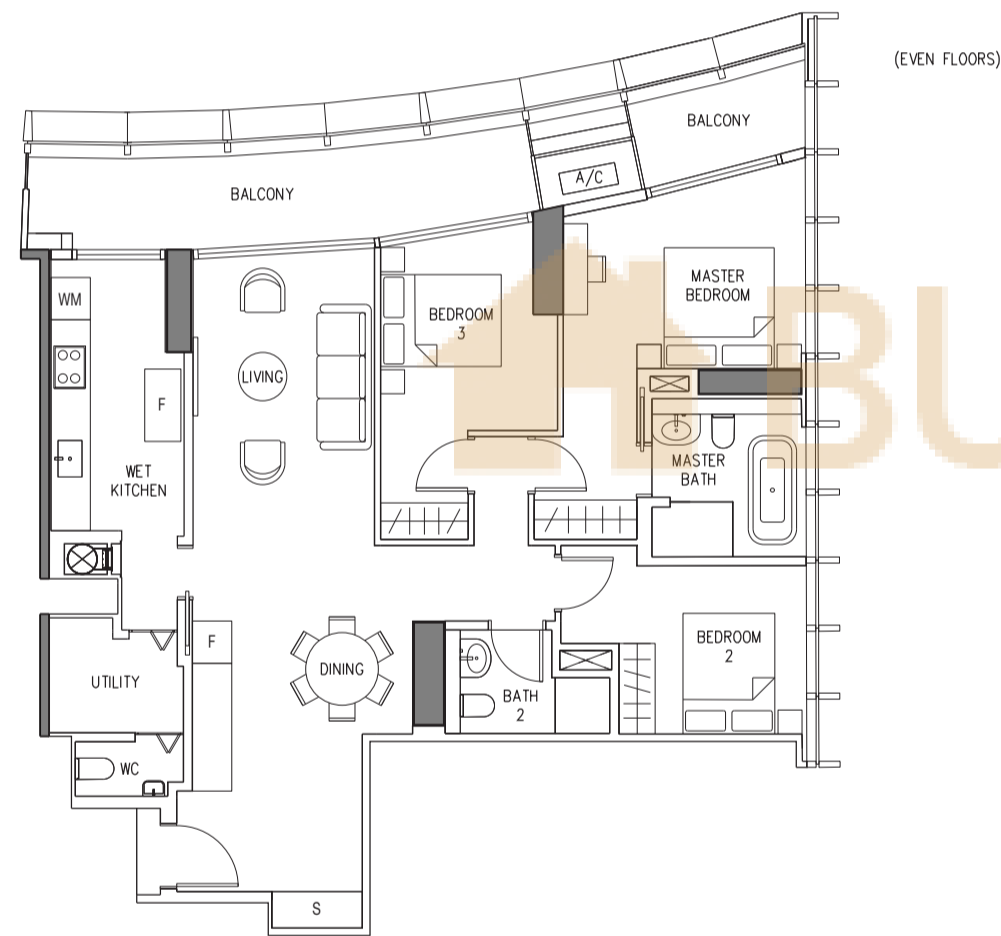
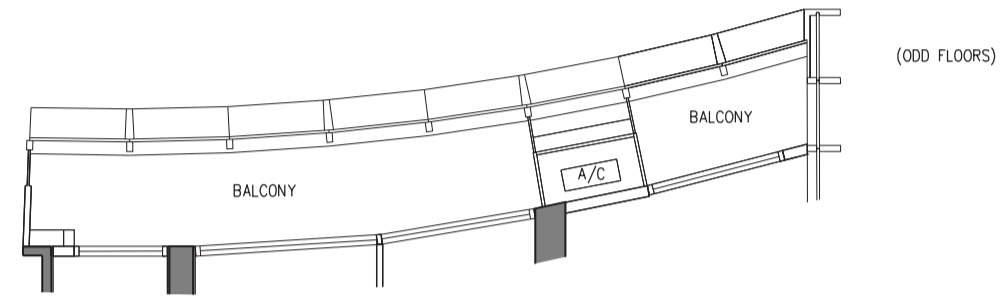
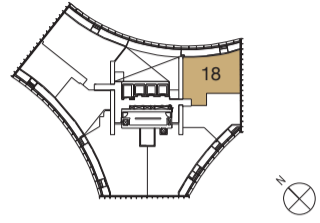

4-Bedroom

Type G1

179 sq.m. / 1,927 sq.ft.
Including 20 sq.m. / 215 sq.ft. of Balcony

#32-11 to #48-11

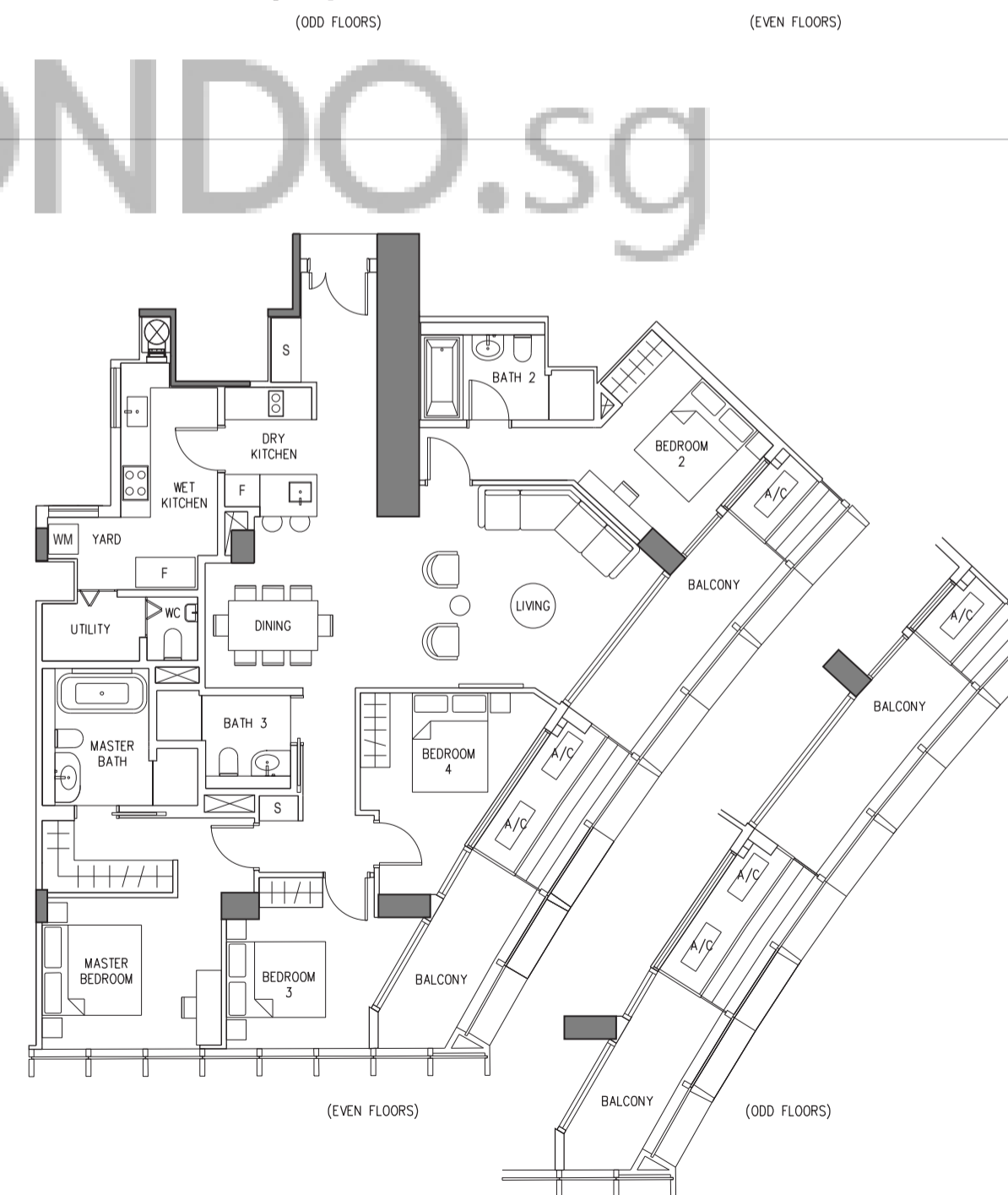
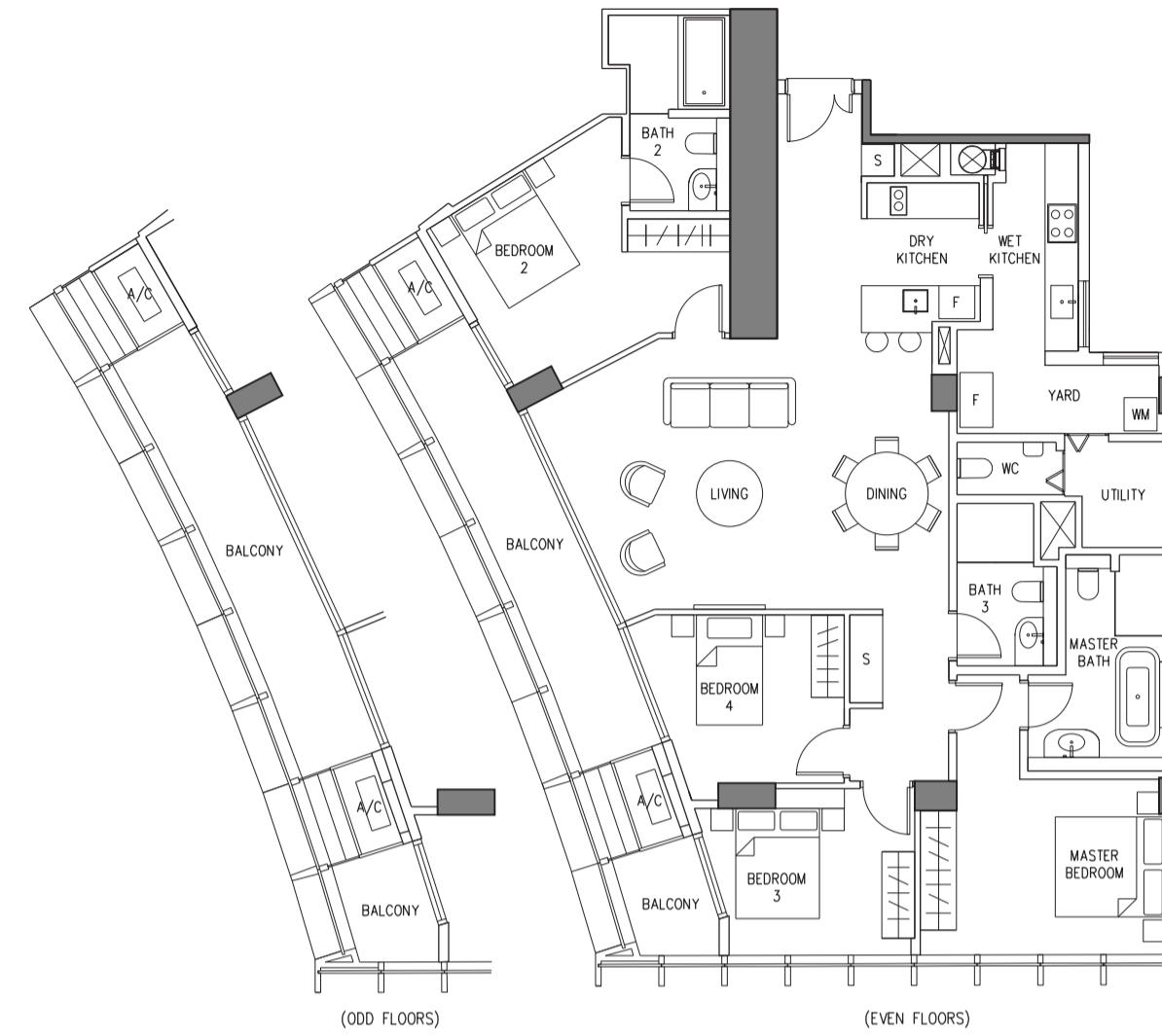
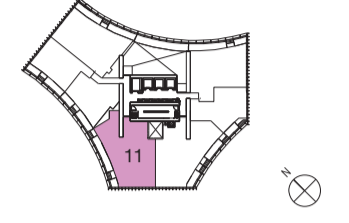

Type G2

171 sq.m. / 1,841 sq.ft.
Including 17 sq.m. / 183 sq.ft. of Balcony

#32-20 to #48-20

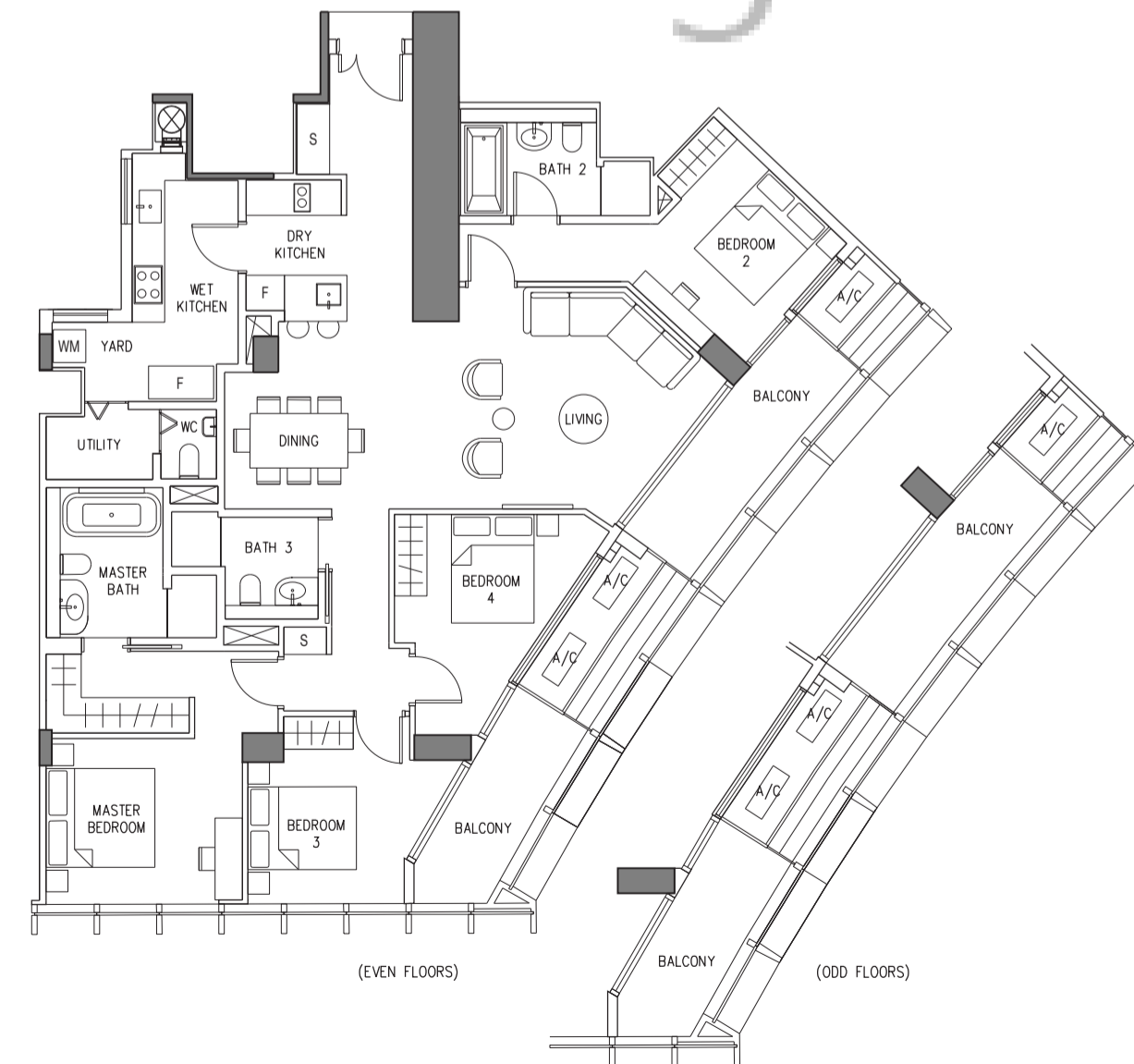
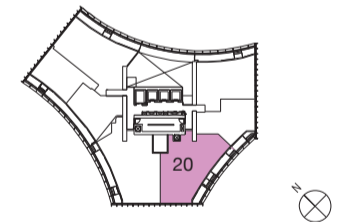

Type PH1

351 sq.m. / 3,778 sq.ft.
Including 55 sq.m. / 592 sq.ft. of Balcony

#48-15

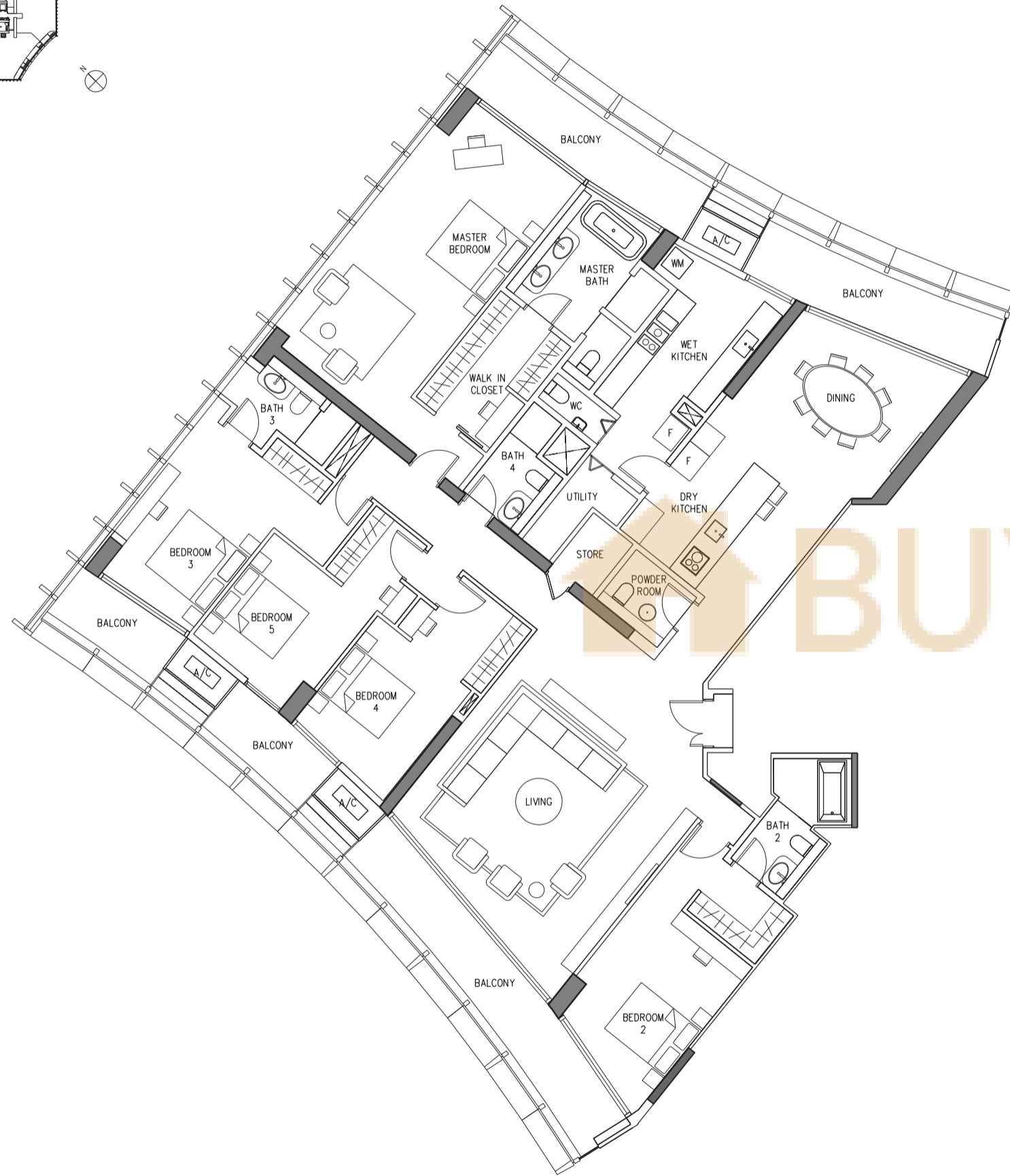
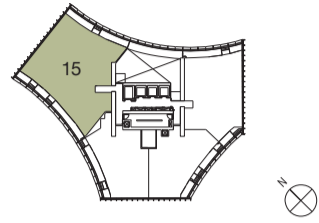

Type PH2

234 sq.m. / 2,519 sq.ft.
Including 27 sq.m. / 291 sq.ft. of Balcony

#48-18

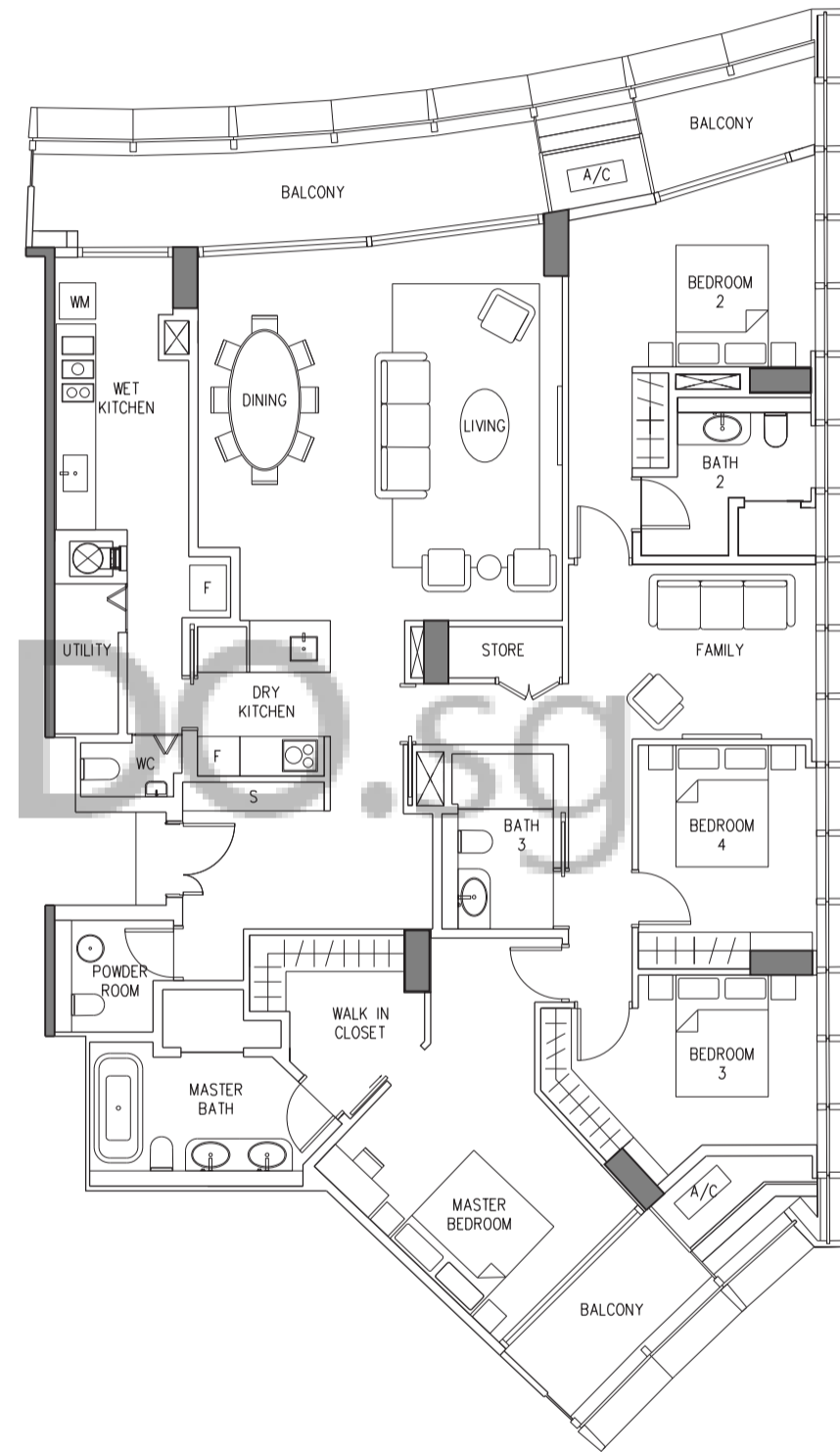
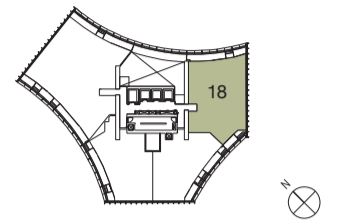

Type PH3

408 sq.m. / 4,392 sq.ft.
Including 100 sq.m. / 1,076 sq.ft. of
Balcony and Terrace

#49-15

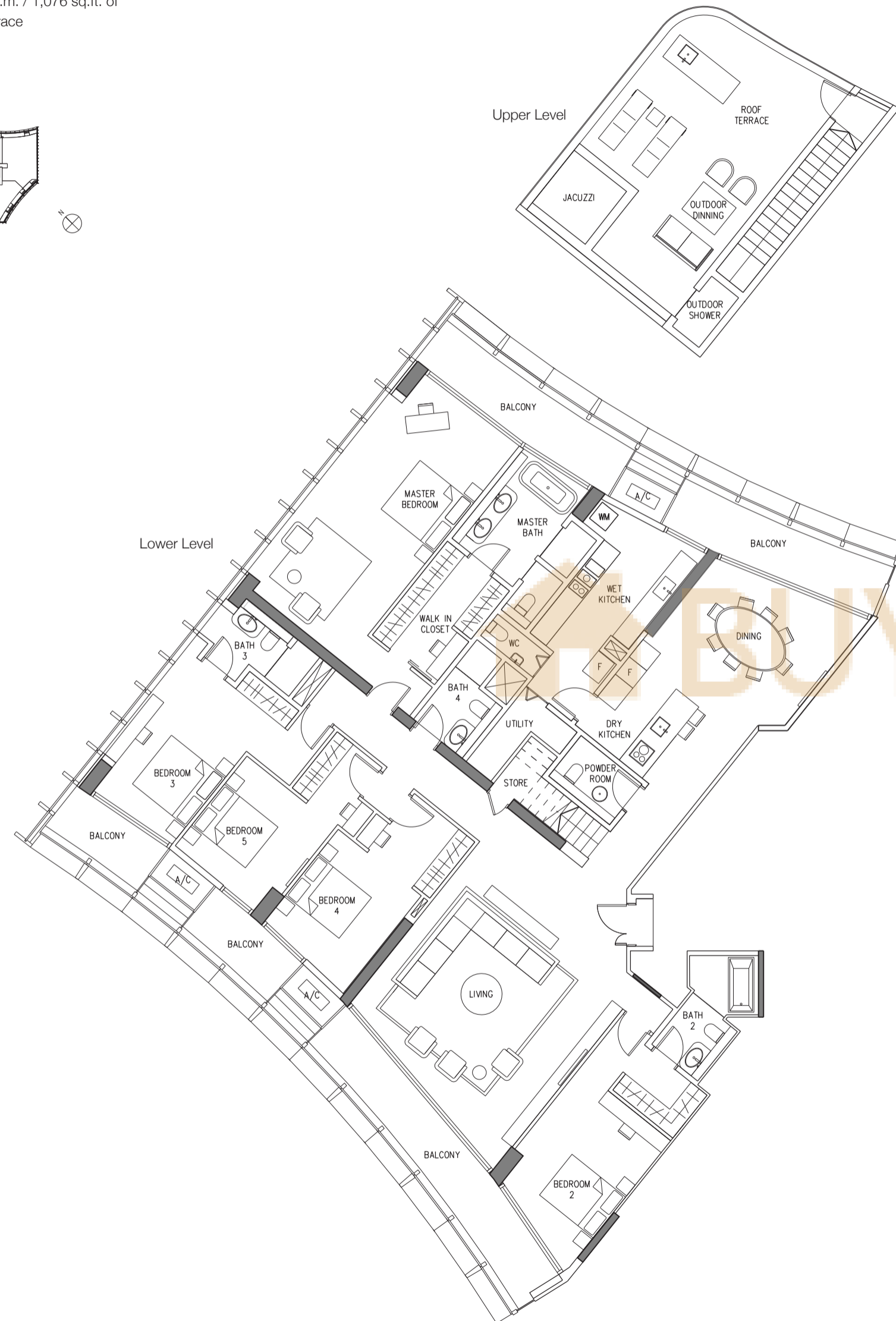
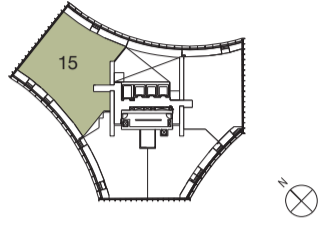

Type PH4

299 sq.m. / 3,218 sq.ft.
Including 79 sq.m. / 850 sq.ft. of
Balcony and Terrace

#49-18

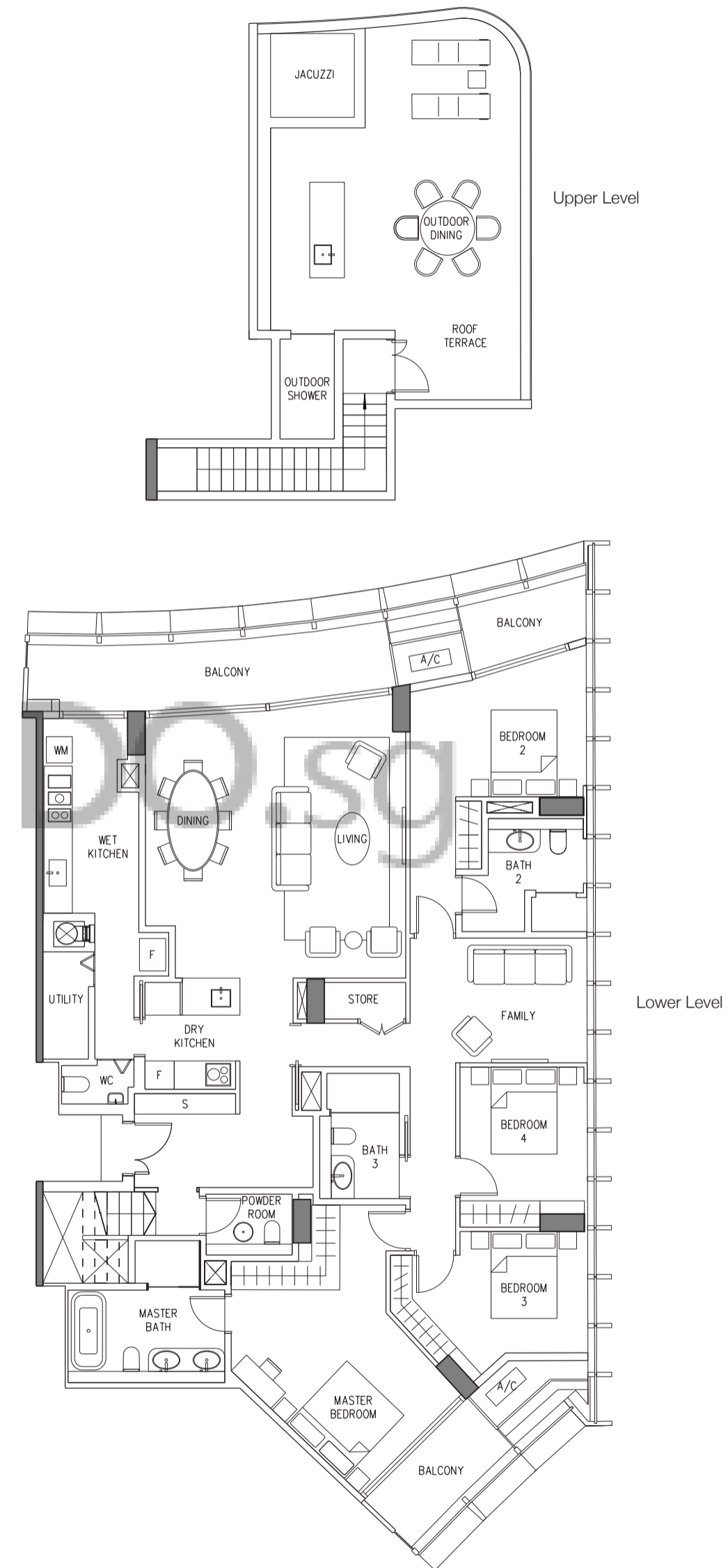
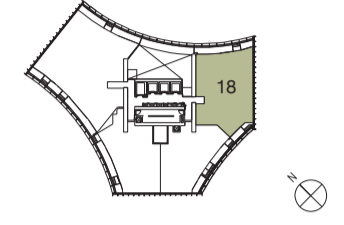

Type PH5

232 sq.m. / 2,497 sq.ft.
Including 65 sq.m. / 700 sq.ft. of Balcony,
Terrace and Void

#49-11

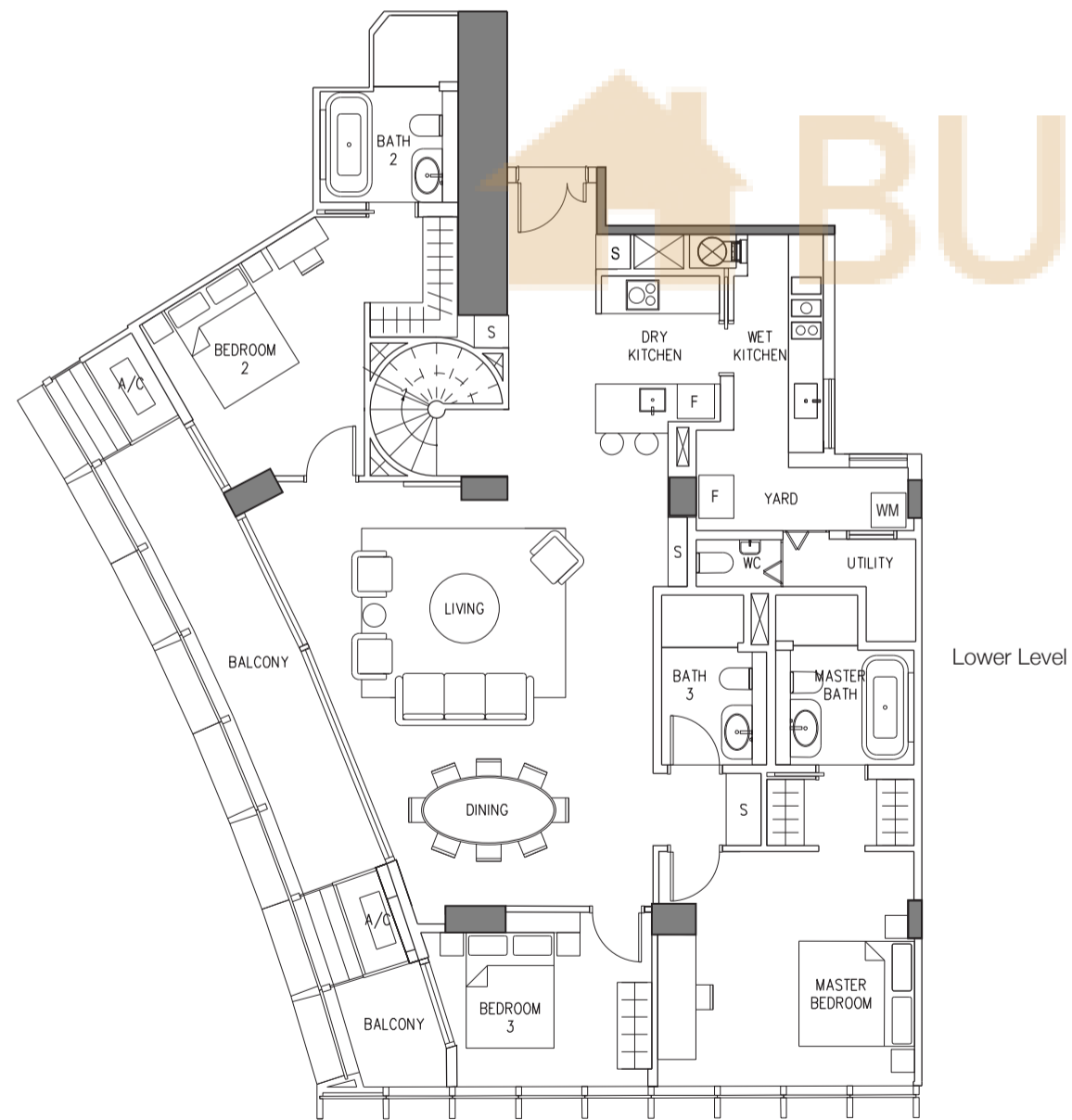
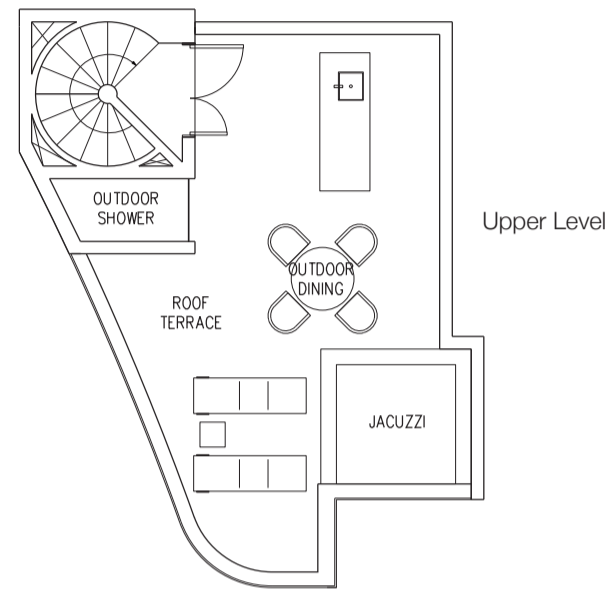
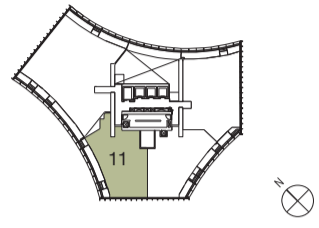

Type PH6

222 sq.m. / 2,390 sq.ft.
Including 63 sq.m. / 678 sq.ft. of Balcony,
Terrace and Void

#49-20

