

Unit Plan

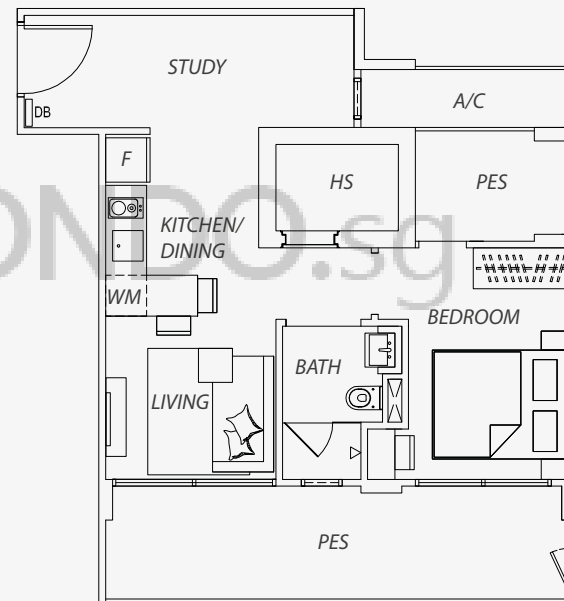

1A Type 1A (PES)
47 sqm
Aster: #01-01
Clover: #01-11

1B Type 1B (PES)
59 sqm
Aster: #01-05 & #01-06
Clover: #01-07 & #01-08

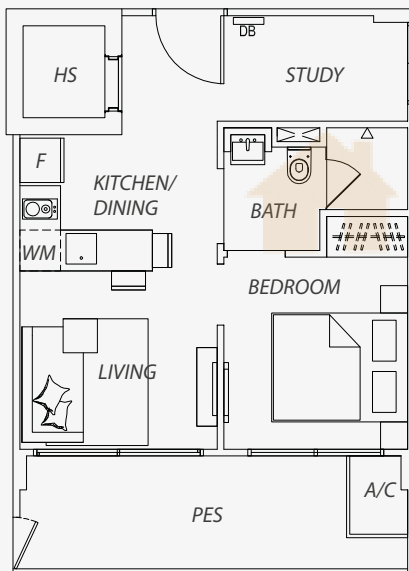
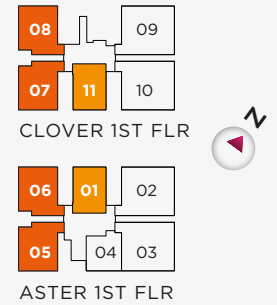
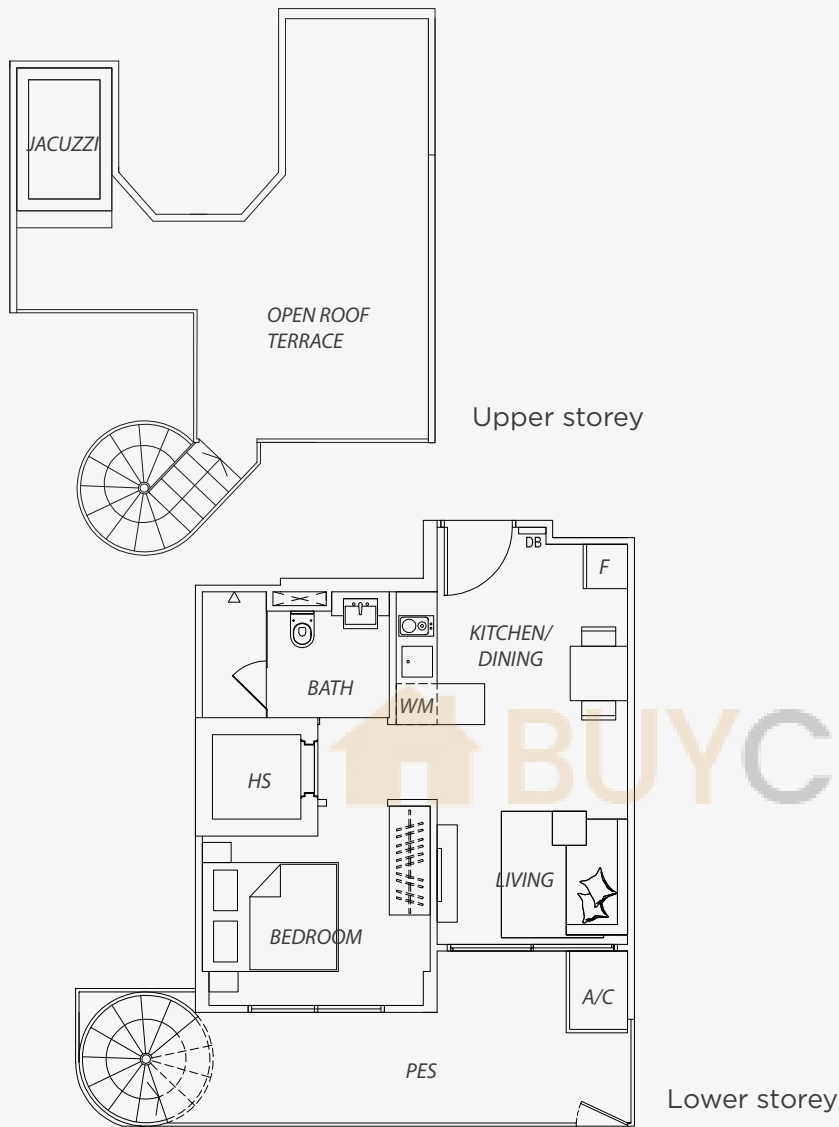

1C Type 1C
84 sqm
Aster: #01-04

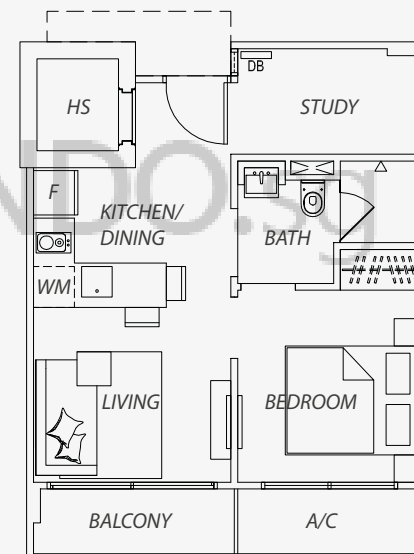
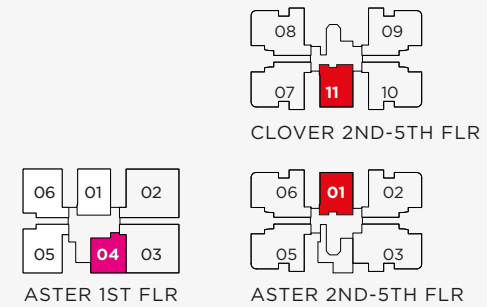

1D Type 1D
45 sqm
Aster: #02-01, #03-01, #04-01 & #05-01
Clover: #02-11, #03-11, #04-11 & #05-11

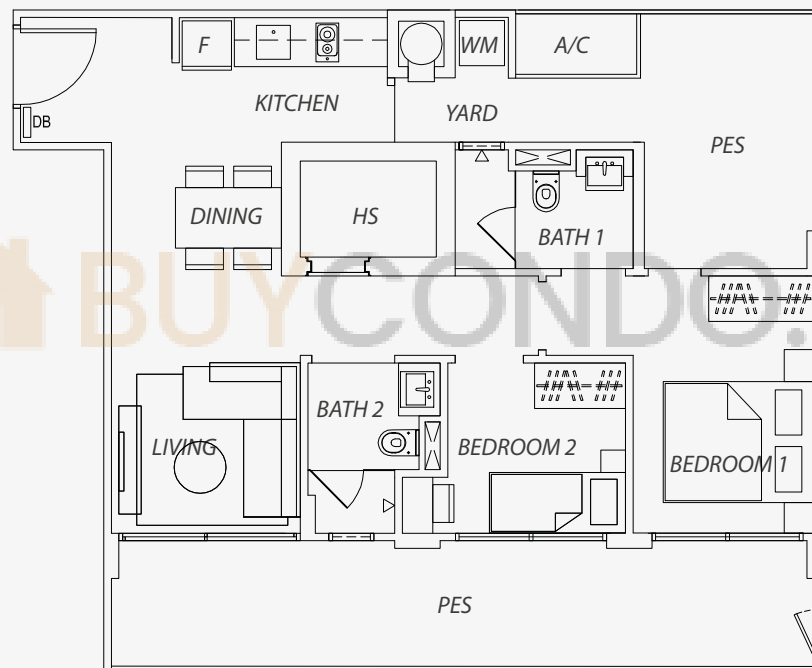
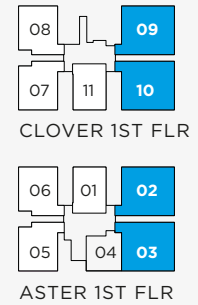

2A Type 2A (PES)

2A

83 sqm

Aster: #01-02 & #01-03

Clover: #01-09 & #01-10

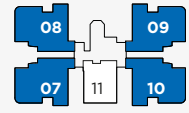

CLOVER 2ND FLR

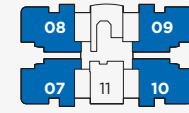

CLOVER 4TH FLR

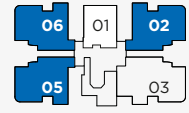

ASTER 2ND FLR

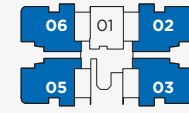

ASTER 4TH FLR

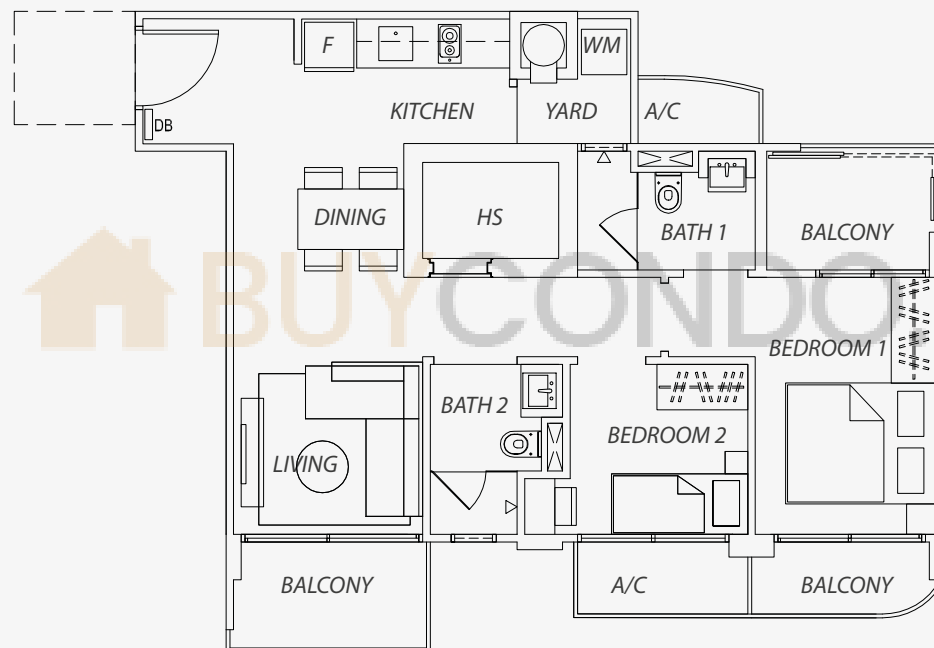

2B Type 2B

72 sqm/73 sqm

Aster: #02-02, #02-05, #02-06 (72 sqm)

#04-02, #04-03, #04-05, #04-06 (73 sqm)

Clover: #02-07, #02-08, #02-09, #02-10 (72 sqm)

#04-07, #04-08, #04-09, #04-10 (73 sqm)

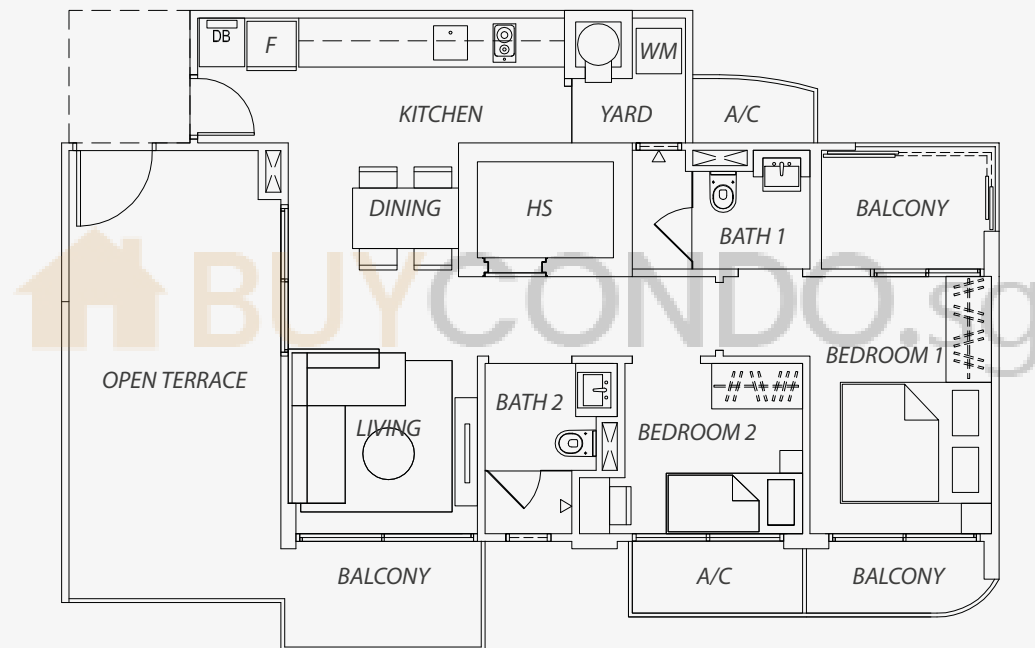
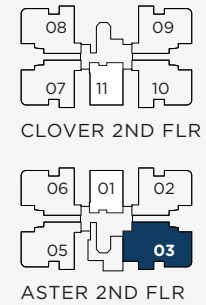

2C Type 2C
 90 sqm
 Aster: #02-03

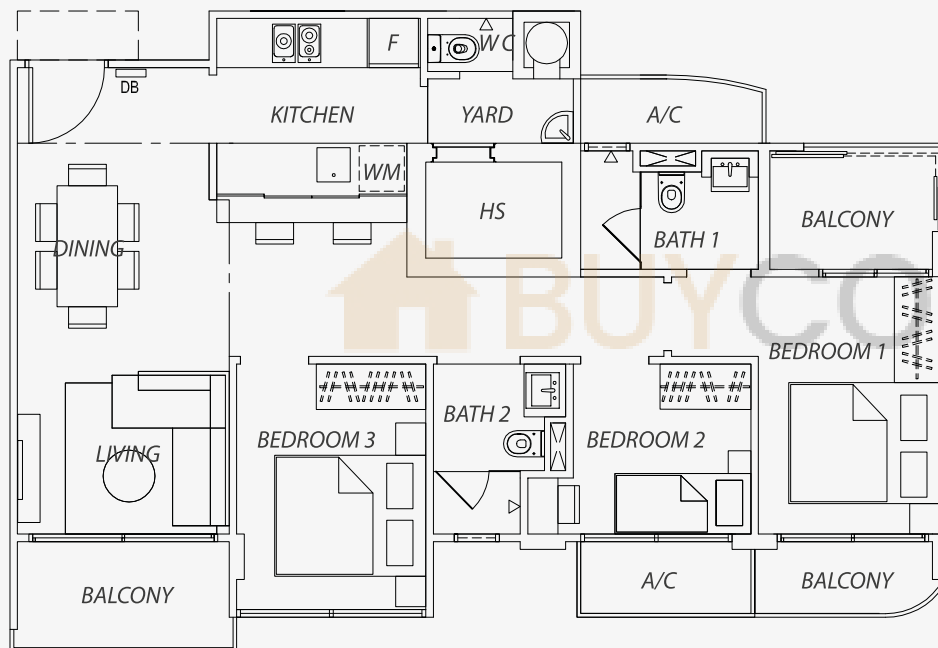
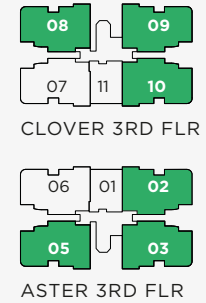

3A Type 3A

104 sqm

Aster: #03-02, #03-03 & #03-05
Clover: #03-08, #03-09 & #03-10

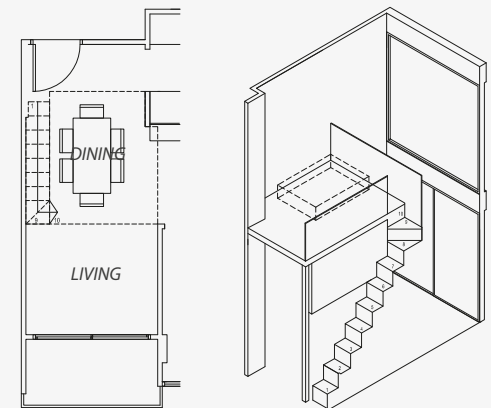

Suggested loft layout for entertainment/study area

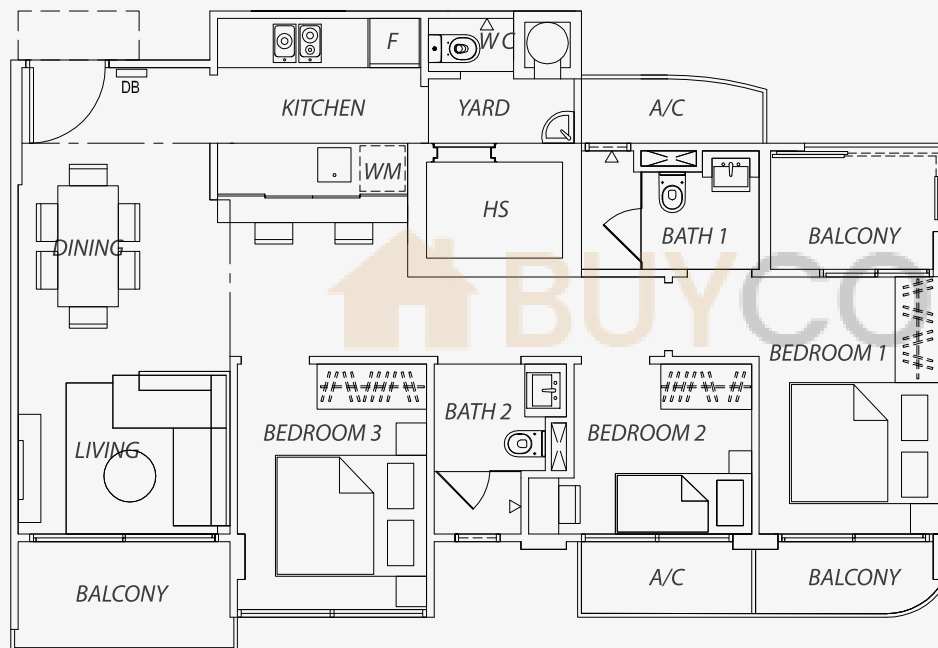
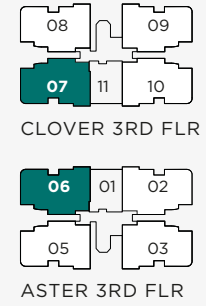

3B Type 3B
104 sqm
Aster: #03-06
Clover: #03-07

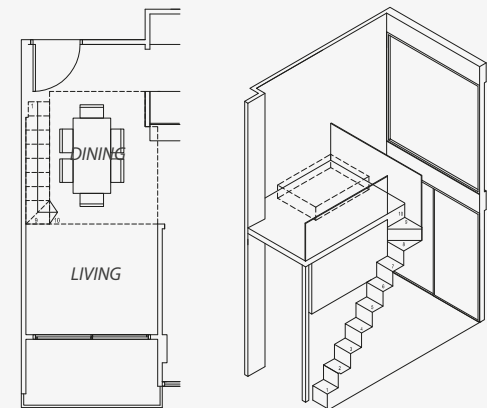

Suggested loft layout for entertainment/study area