

# SEMI-DETACHED

## TYPE A

STRATA AREA:  
365 sq m / 3929 sq ft

HOUSE NOS:  
369-379, 575, 577

Mirror Image:  
365, 367, 559-573

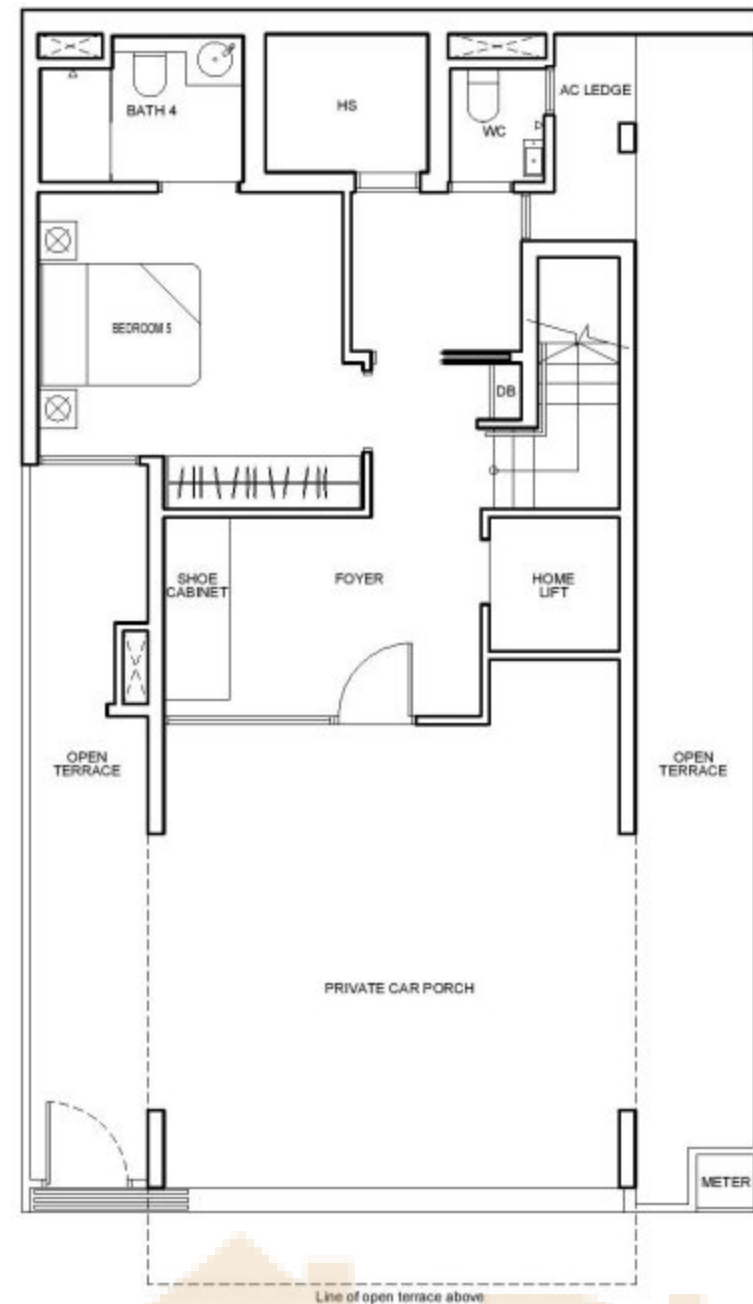

1ST STOREY

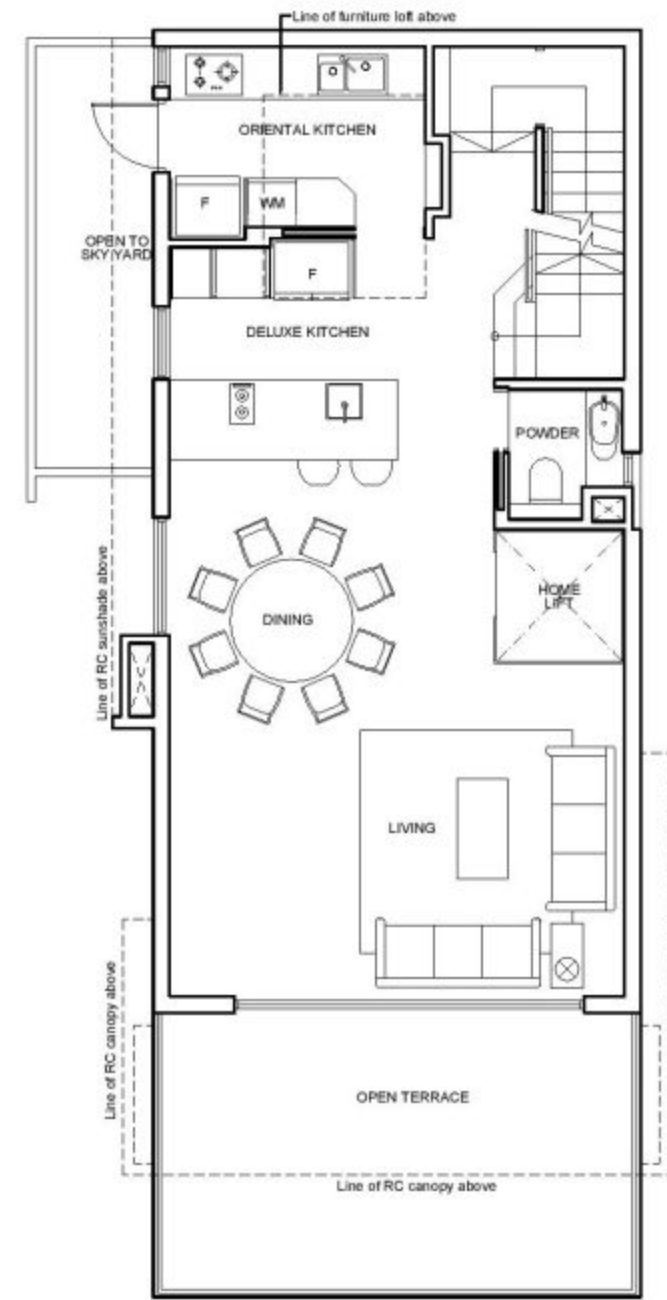

2ND STOREY

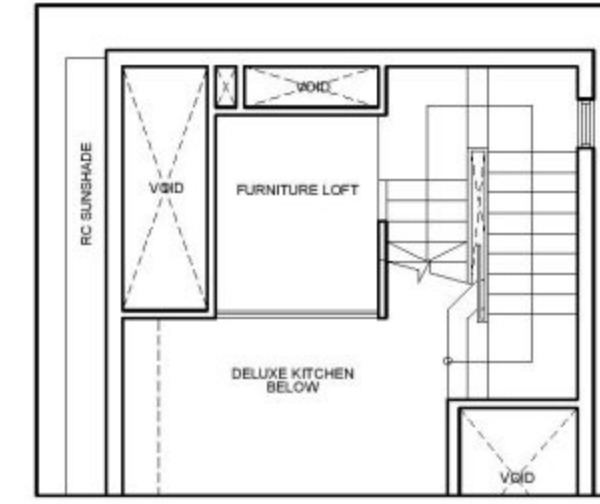

LOFT - PLAN

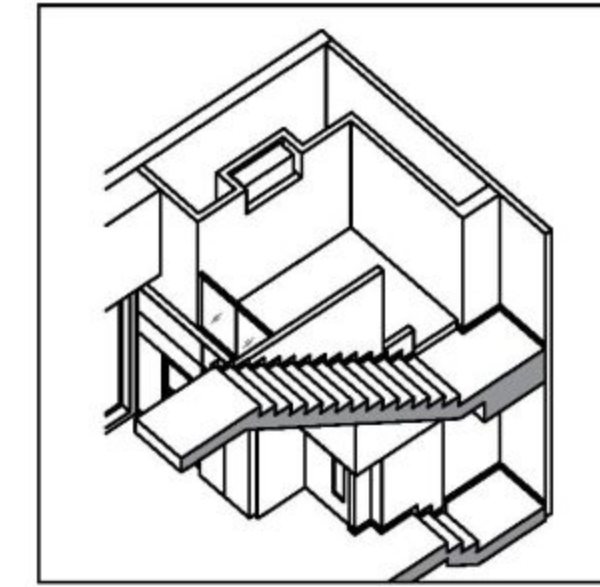

LOFT - ISOMETRIC VIEW

### LEGENDS FOR FLOOR PLAN

- HS – Household shelter
- WC – Water closet
- DB – Distribution board
- WM – Washing machine
- F – Fridge
- PES – Private enclosed space
- M&E – Mechanical & Electrical
- CTL – Control Lift Panel
- ⊗ – Void

Units may have different columns in the basement (refer to BP Plan). All areas are inclusive of air-con ledge, open roof terrace, open to sky terrace, PES and void, if any. Furniture are indicative only and not provided. All plans are subject to amendment as approved by the relevant authorities. Floor areas are approximate measurements only and are subject to final survey.

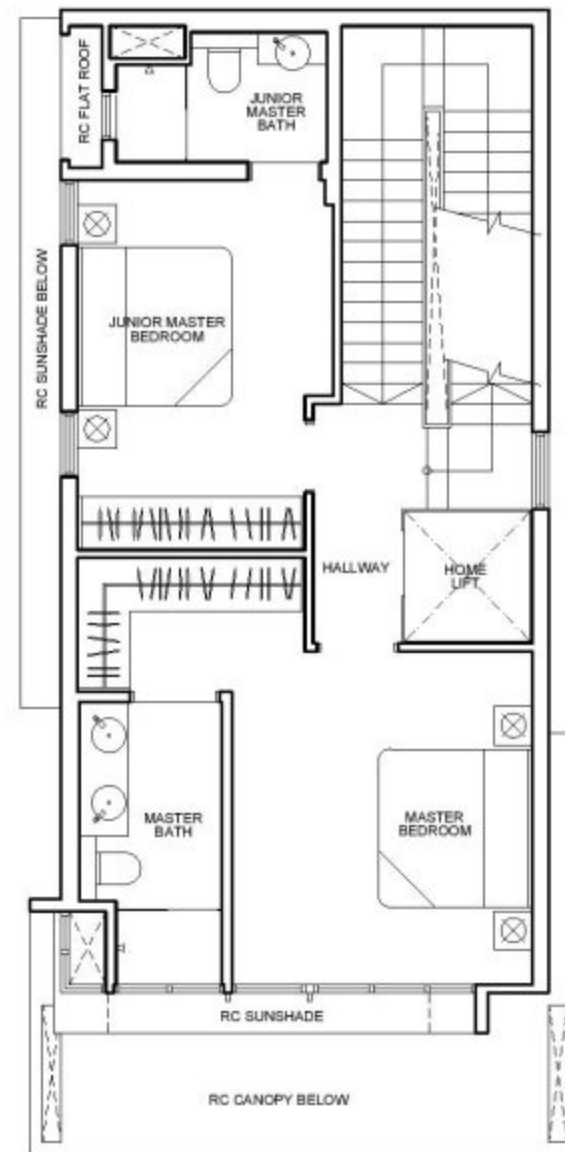
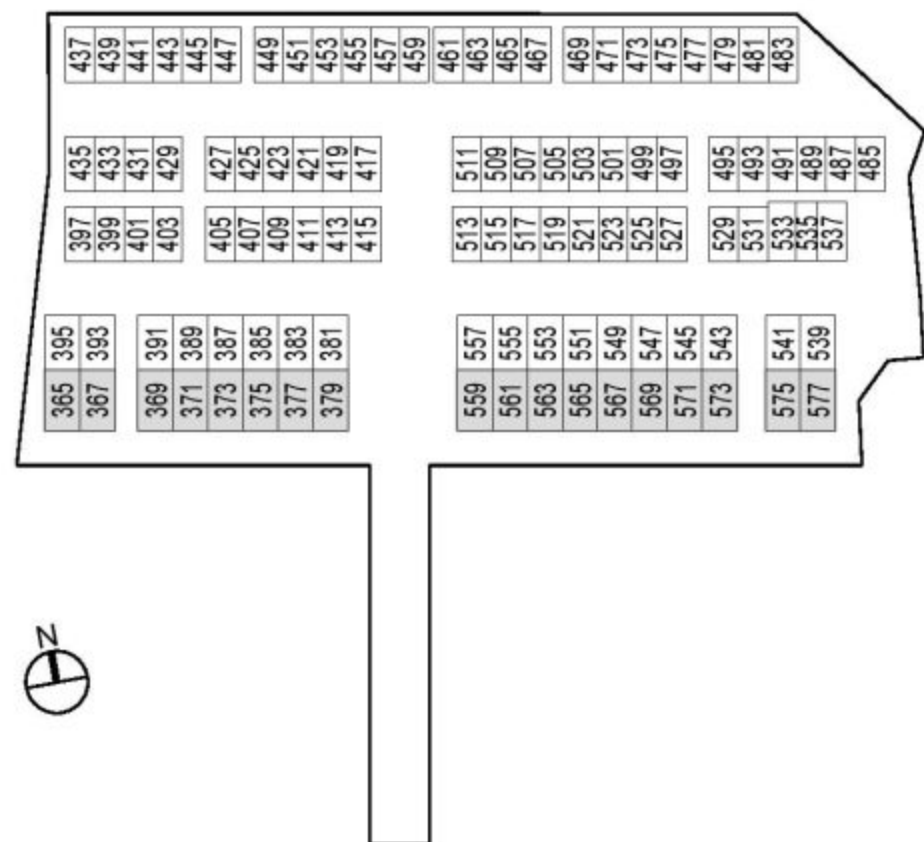

3RD STOREY

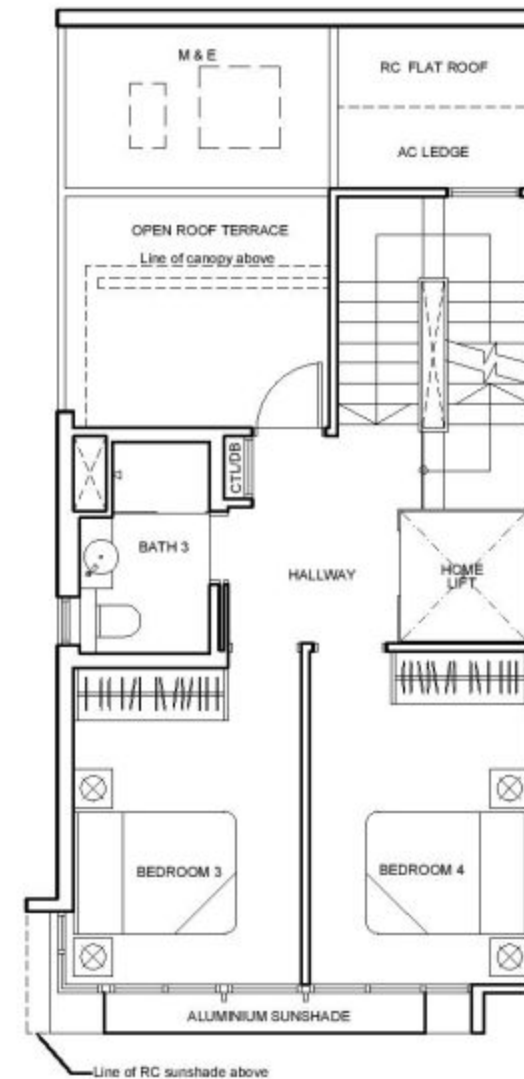

ATTIC

# SEMI-DETACHED

## TYPE B

STRATA AREA:  
406 sq m / 4370 sq ft

HOUSE NOS:  
381-391, 539, 541

Mirror Image:  
393, 395, 543-557

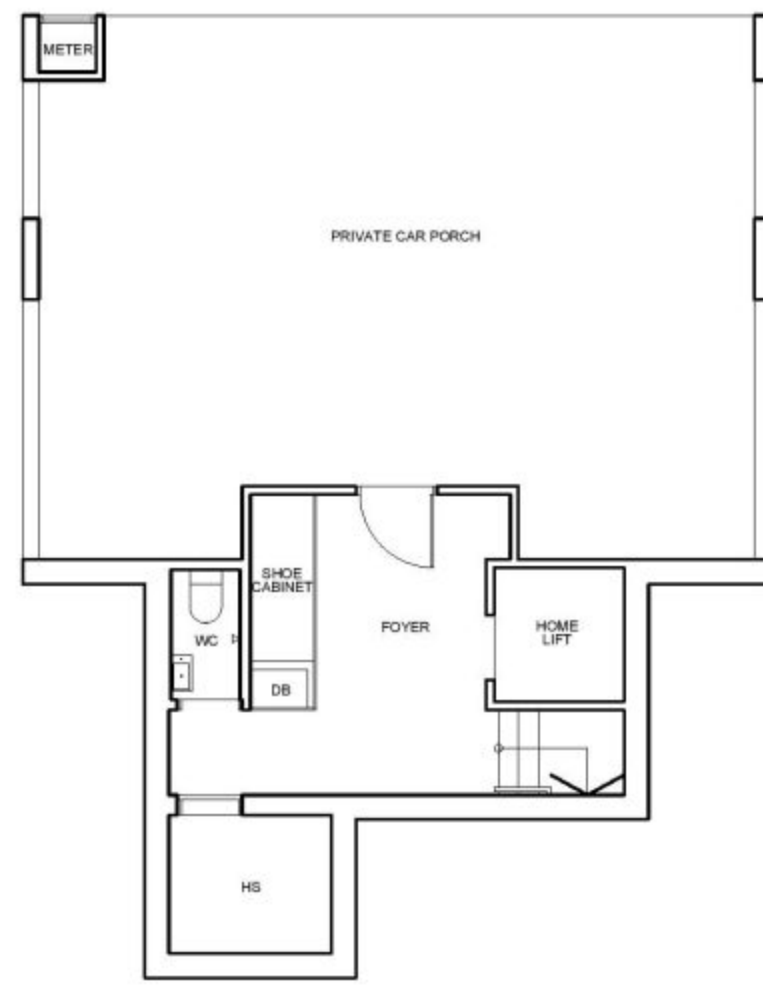

BASEMENT

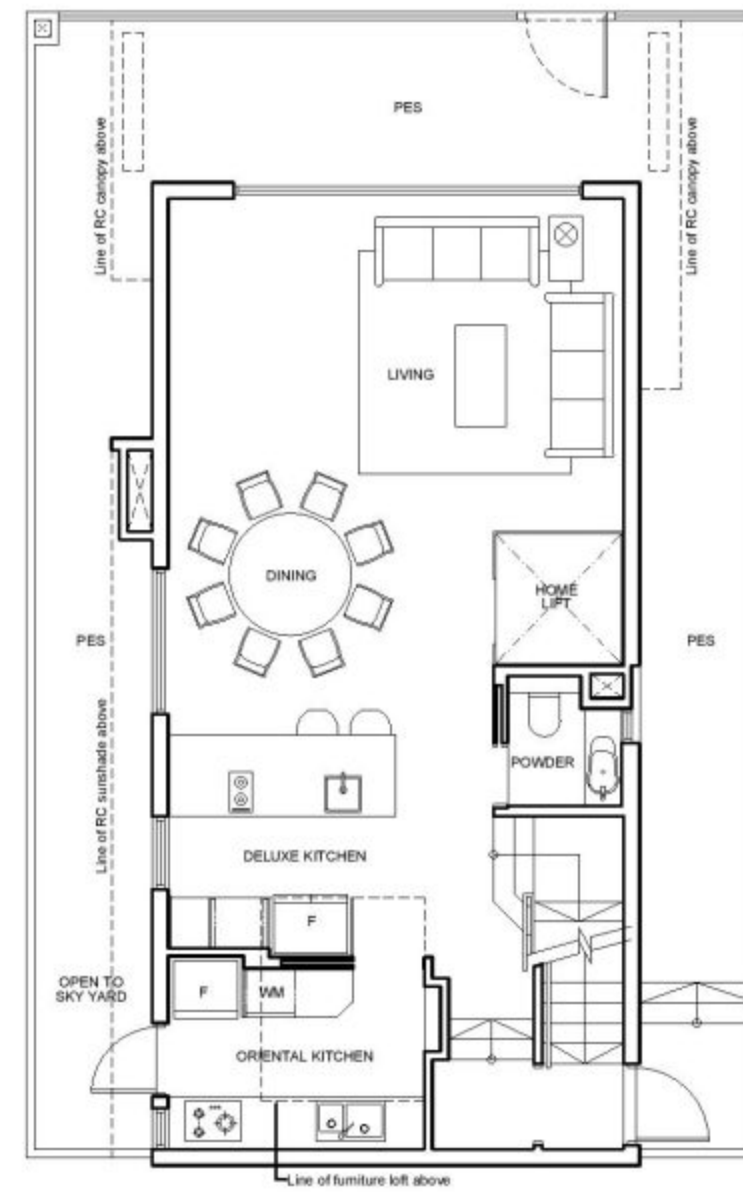

1ST STOREY

### LEGENDS FOR FLOOR PLAN

- HS – Household shelter
- WC – Water closet
- DB – Distribution board
- WM – Washing machine
- F – Fridge
- PES – Private enclosed space
- M&E – Mechanical & Electrical
- CTL – Control Lift Panel
- ☒ – Void

Units may have different columns in the basement (refer to BP Plan). All areas are inclusive of air-con ledge, open roof terrace, open to sky terrace, PES and void, if any. Furniture are indicative only and not provided. All plans are subject to amendment as approved by the relevant authorities. Floor areas are approximate measurements only and are subject to final survey.

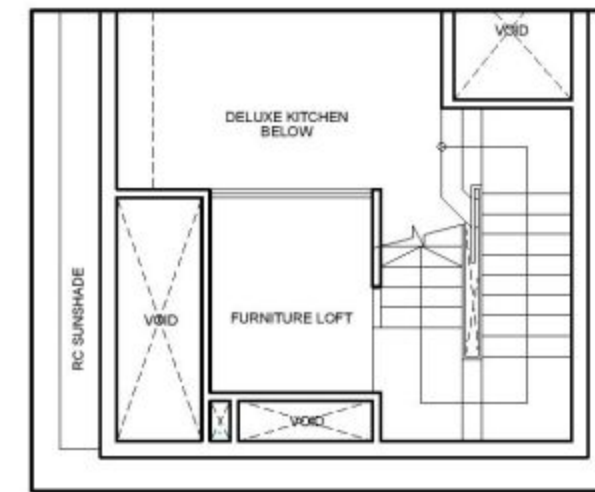

LOFT - PLAN

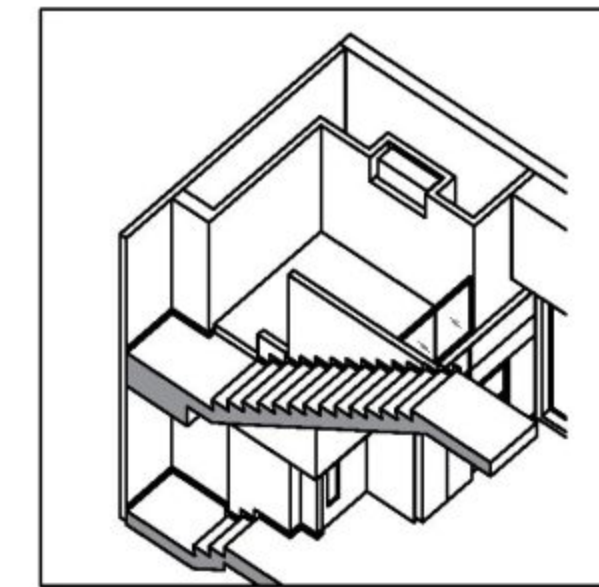

LOFT - ISOMETRIC VIEW

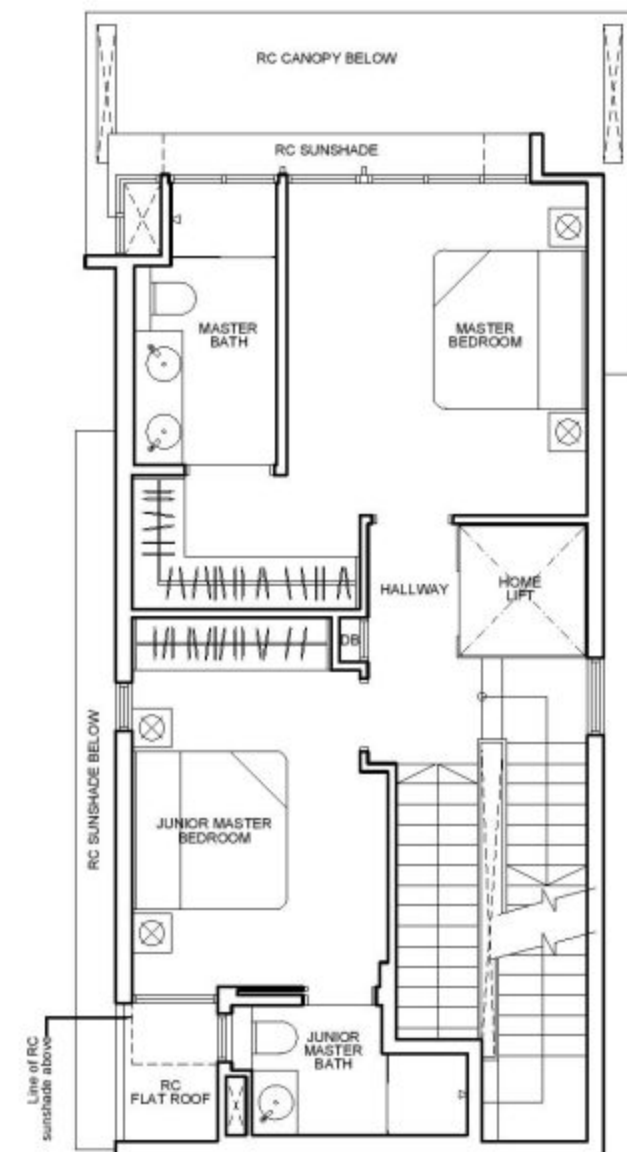
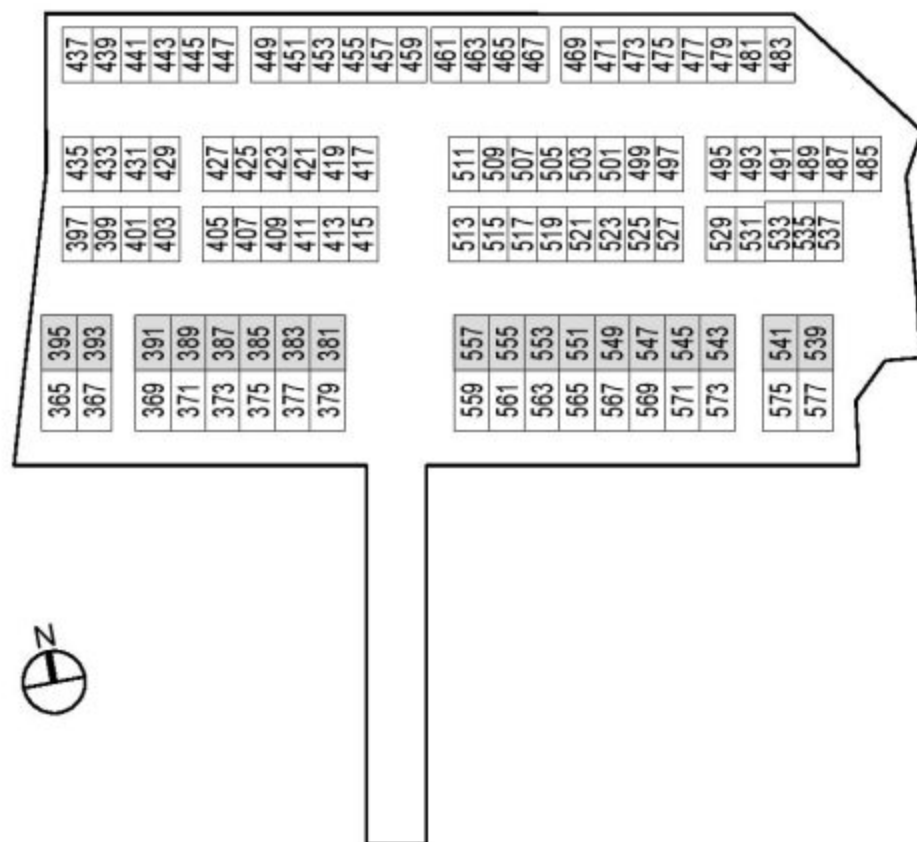

2ND STOREY

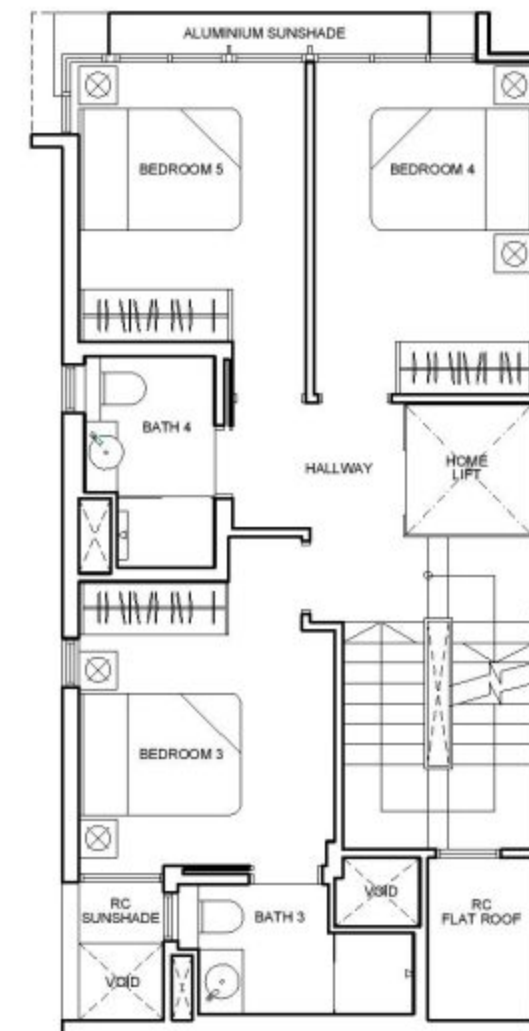

3RD STOREY

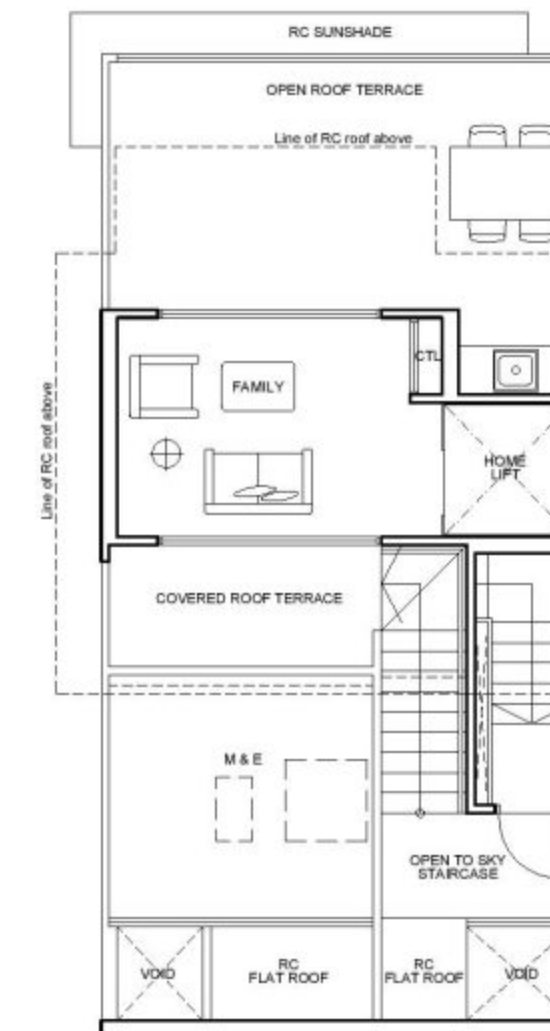

ROOF TERRACE

# SEMI-DETACHED

## TYPE C

STRATA AREA:  
377 sq m / 4058 sq ft

### HOUSE NOS:

399, 403, 407, 411, 415, 419, 423,  
427, 431, 435, 439, 443, 447, 451,  
455, 459, 463, 467, 471, 475, 479,  
483, 487, 491, 495, 499, 503, 507,  
511, 515, 519, 523, 527, 531

### Mirror Image:

397, 401, 405, 409, 413, 417, 421,  
425, 429, 433, 437, 441, 445, 449,  
453, 457, 461, 465, 469, 473, 477,  
481, 485, 489, 493, 497, 501, 505,  
509, 513, 517, 521, 525, 529



BASEMENT

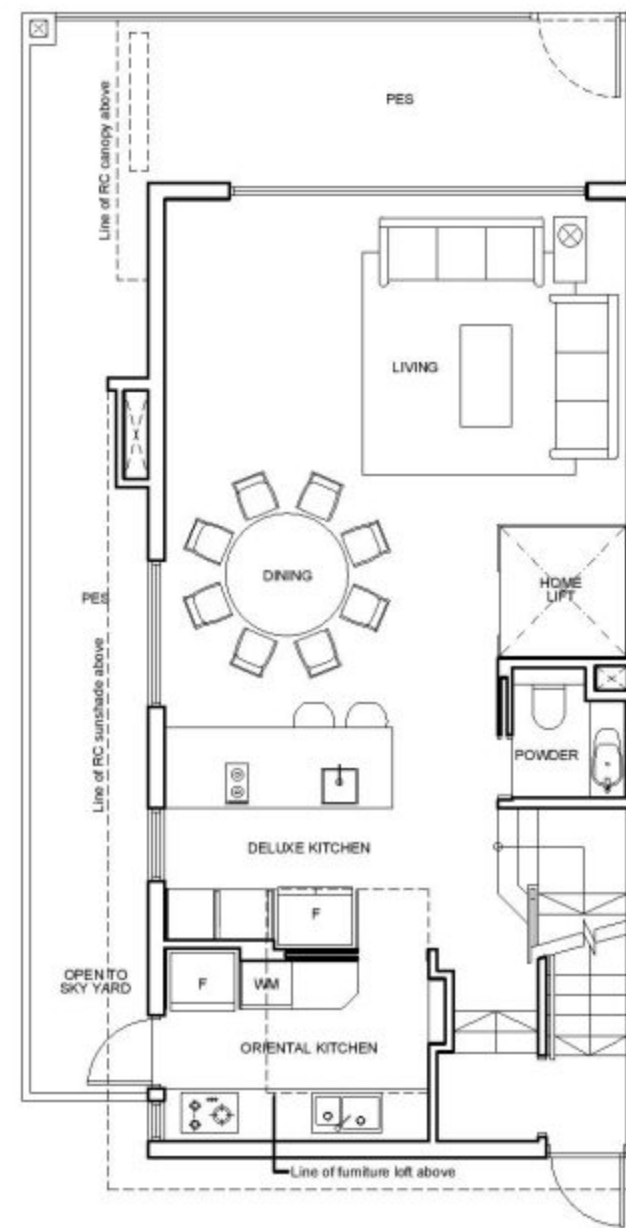

1ST STOREY

### LEGENDS FOR FLOOR PLAN

- HS – Household shelter
- WC – Water closet
- DB – Distribution board
- WM – Washing machine
- F – Fridge
- PES – Private enclosed space
- M&E – Mechanical & Electrical
- CTL – Control Lift Panel
- ⊗ – Void

Units may have different columns in the basement (refer to BP Plan). All areas are inclusive of air-con ledge, open roof terrace, open to sky terrace, PES and void, if any. Furniture are indicative only and not provided. All plans are subject to amendment as approved by the relevant authorities. Floor areas are approximate measurements only and are subject to final survey.

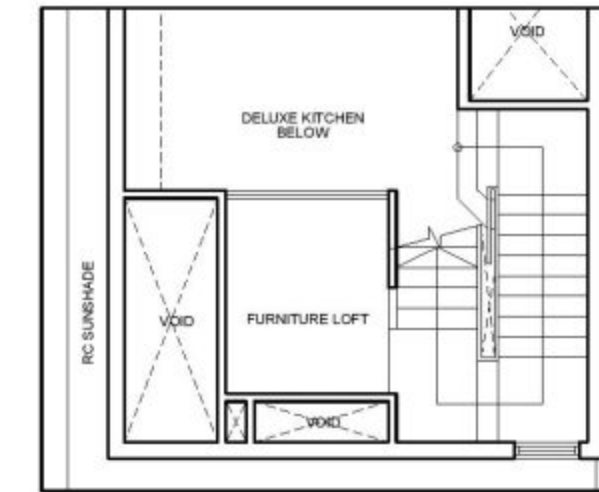

LOFT - PLAN

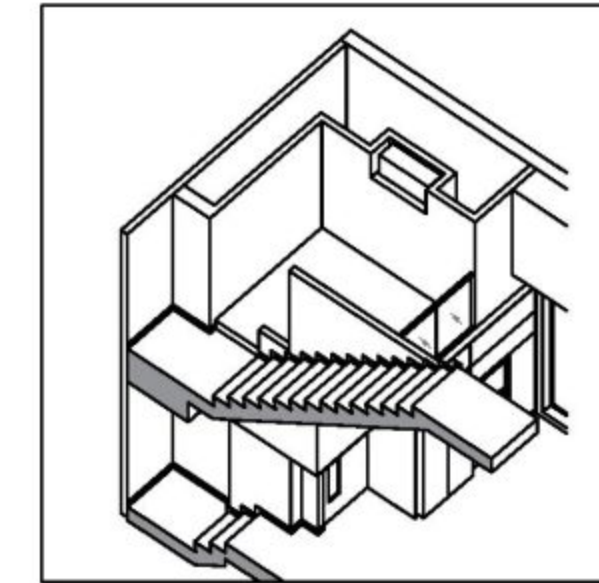

LOFT - ISOMETRIC VIEW

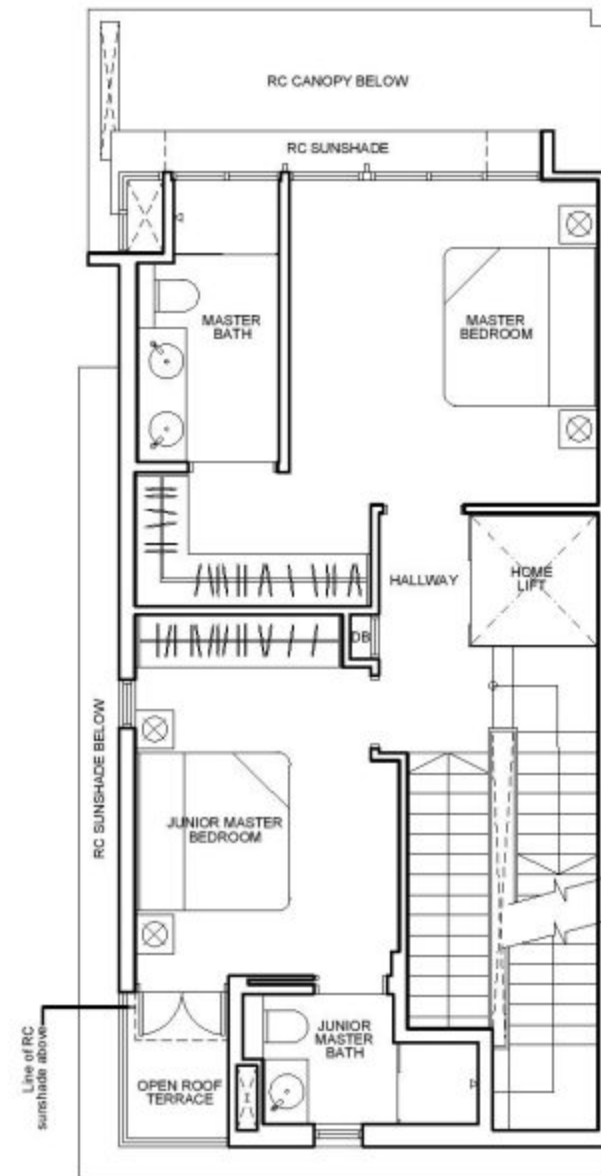
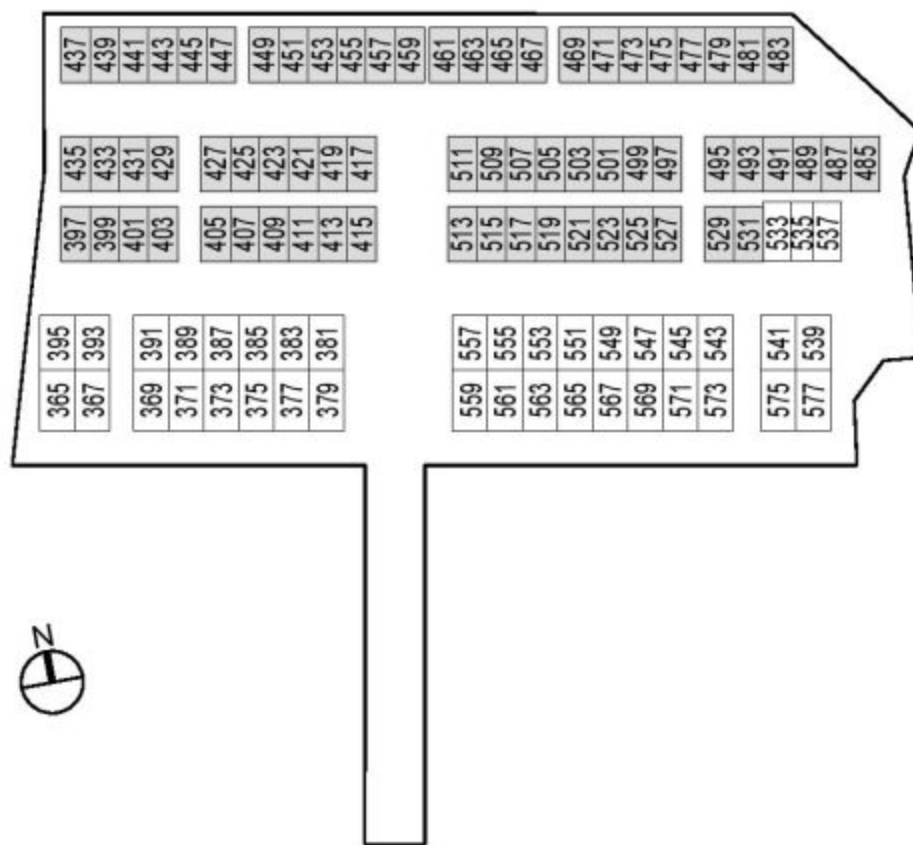

2ND STOREY

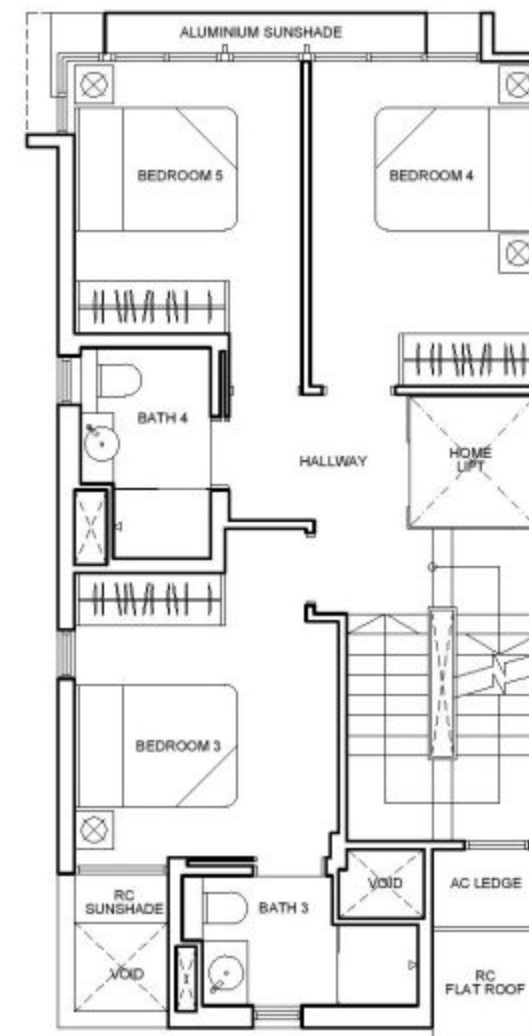

3RD STOREY

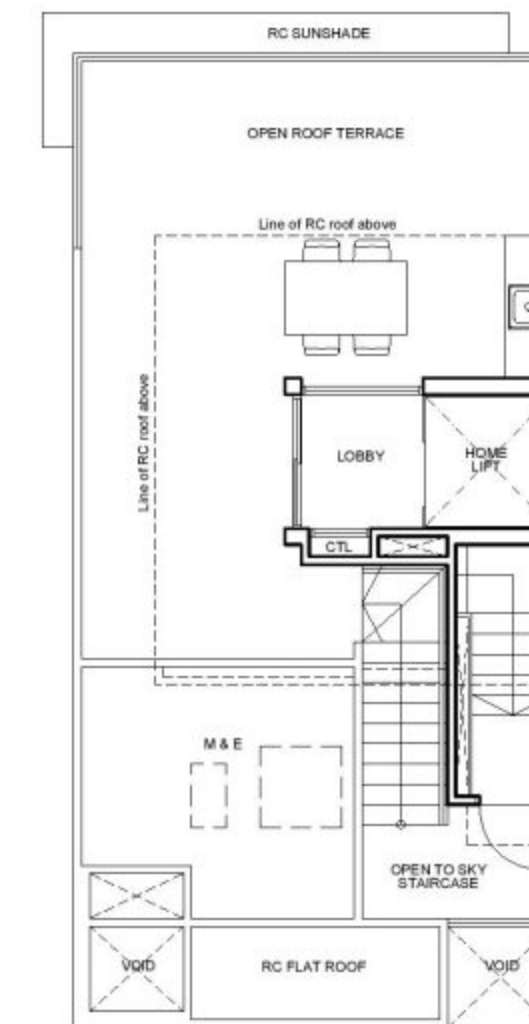

ROOF TERRACE



# TERRACE

## TYPE D1

STRATA AREA:  
339 sq m / 3649 sq ft

HOUSE NOS:  
535



BASEMENT

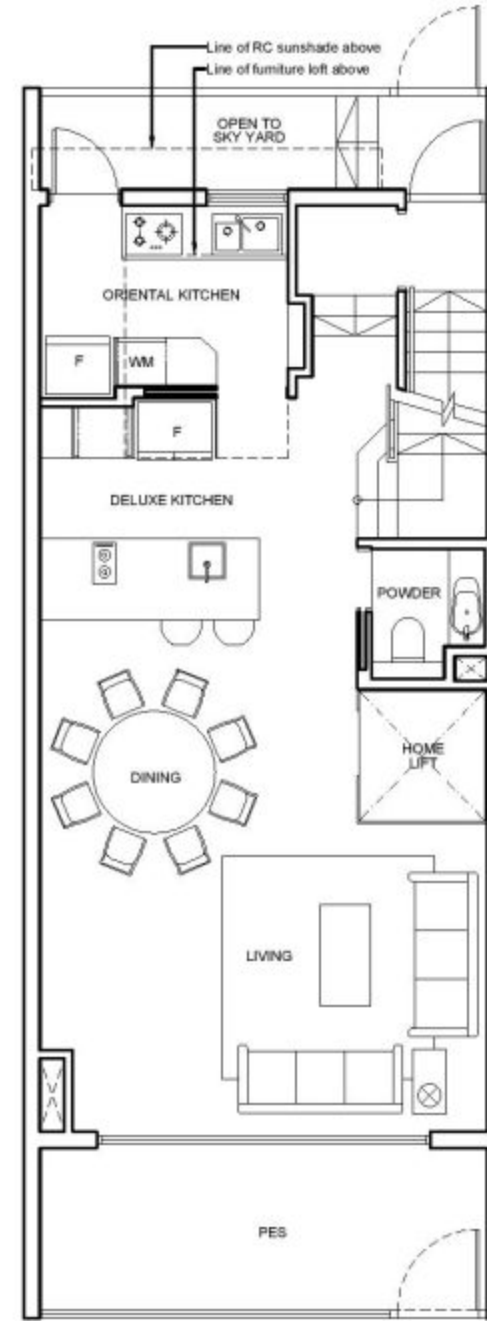

1ST STOREY

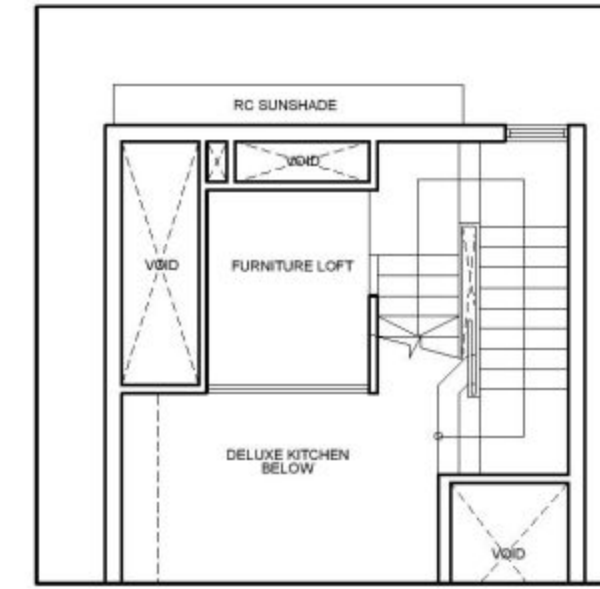

LOFT - PLAN

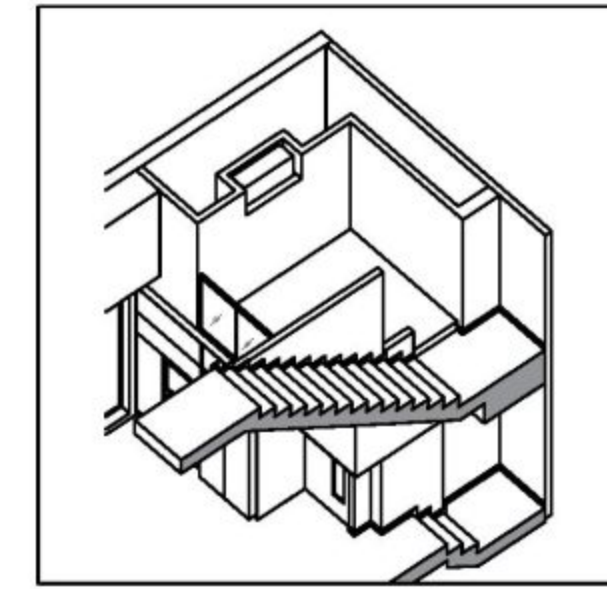

LOFT - ISOMETRIC VIEW

### LEGENDS FOR FLOOR PLAN

- HS – Household shelter
- WC – Water closet
- DB – Distribution board
- WM – Washing machine
- F – Fridge
- PES – Private enclosed space
- M&E – Mechanical & Electrical
- CTL – Control Lift Panel
- ⊗ – Void

Units may have different columns in the basement (refer to BP Plan). All areas are inclusive of air-con ledge, open roof terrace, open to sky terrace, PES and void, if any. Furniture are indicative only and not provided. All plans are subject to amendment as approved by the relevant authorities. Floor areas are approximate measurements only and are subject to final survey.

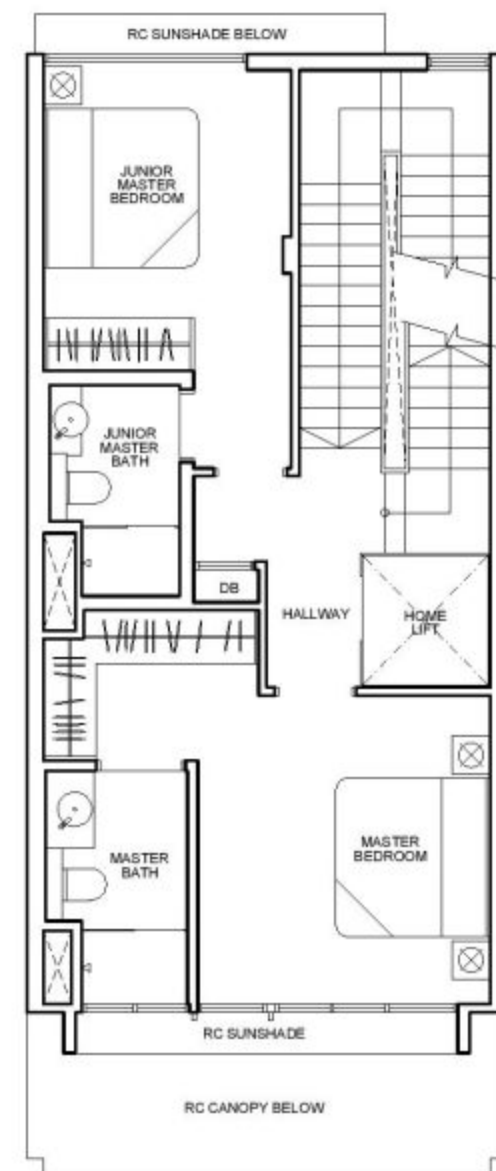
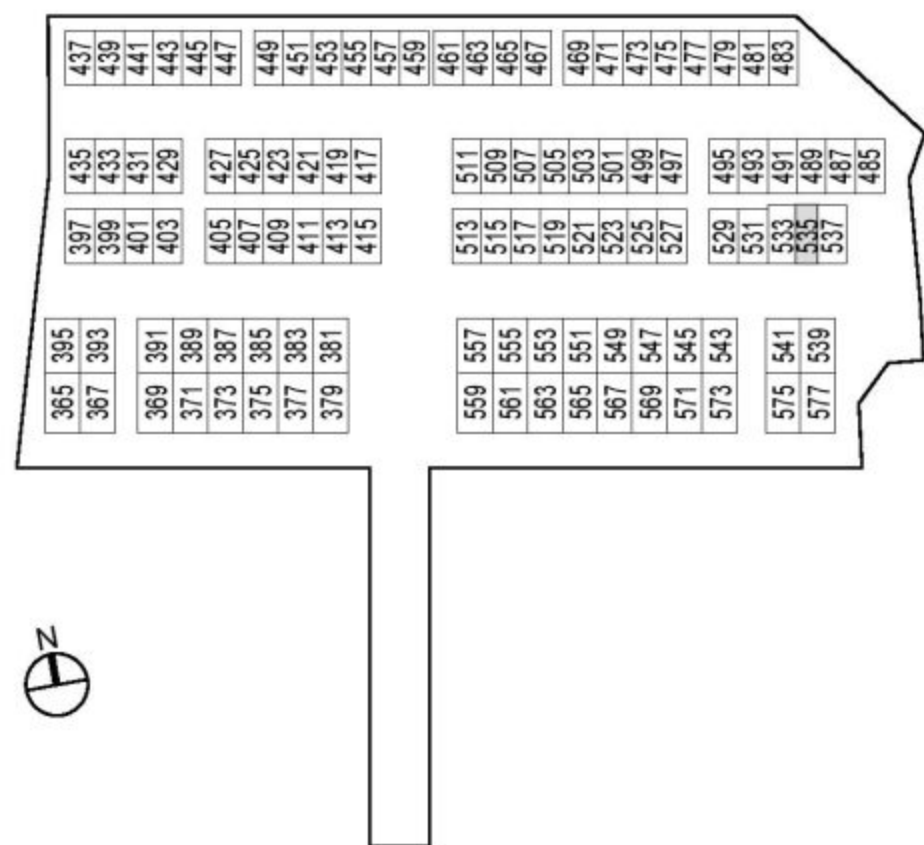

2ND STOREY

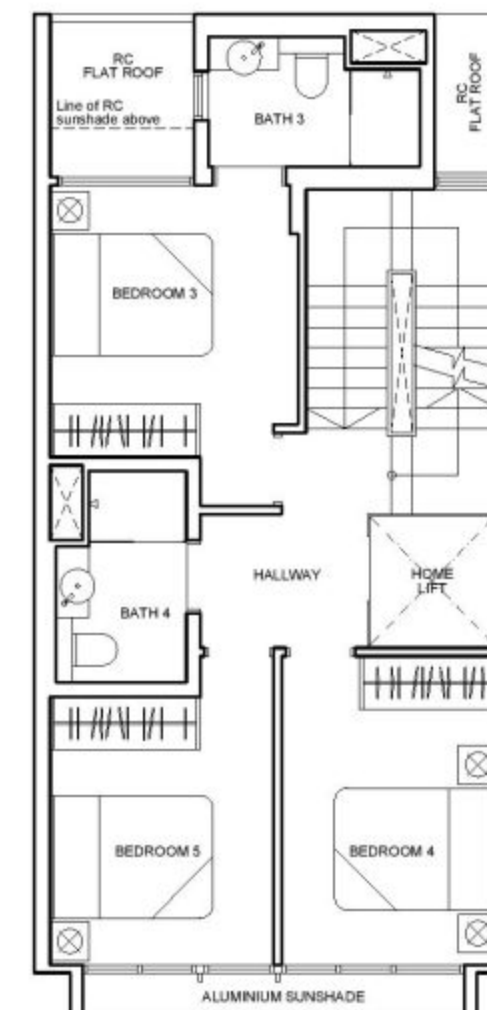

3RD STOREY



ROOF TERRACE



# TERRACE

## TYPE D2

STRATA AREA:  
374 sq m / 4026 sq ft

HOUSE NOS:  
533

Mirror Image:  
537



BASEMENT

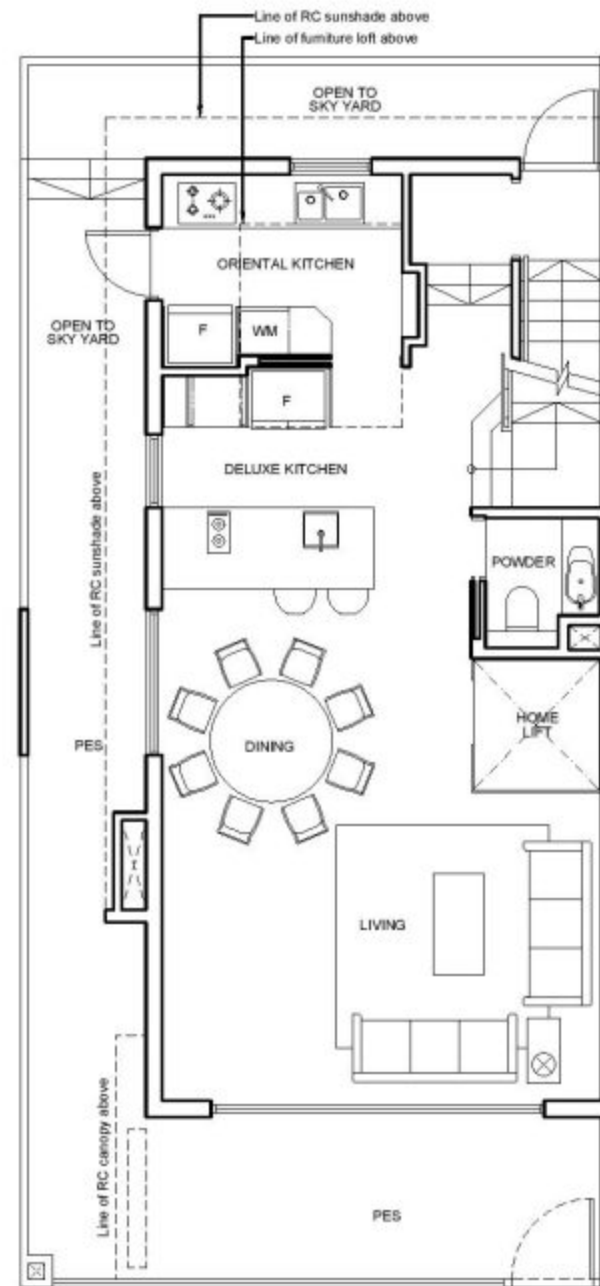

1ST STOREY

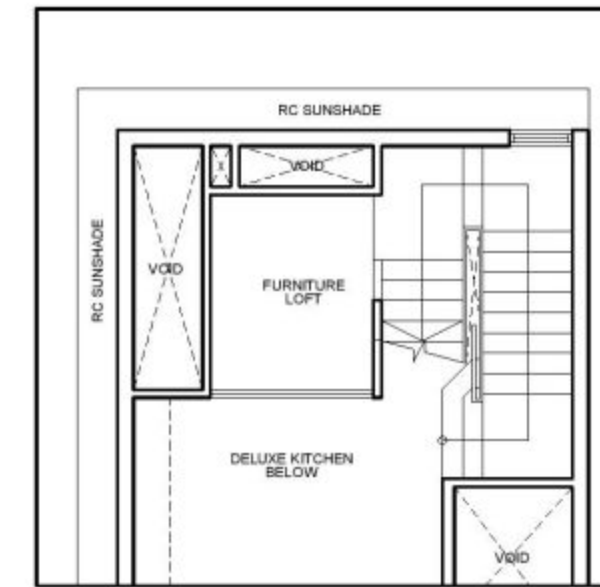

LOFT - PLAN

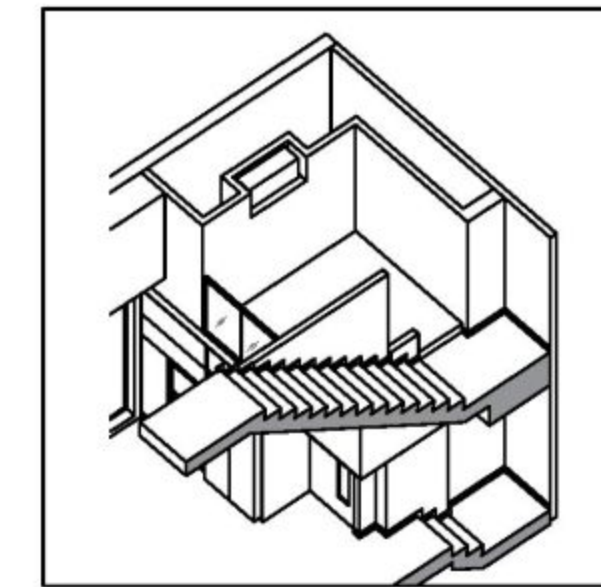

LOFT - ISOMETRIC VIEW

### LEGENDS FOR FLOOR PLAN

- HS – Household shelter
- WC – Water closet
- DB – Distribution board
- WM – Washing machine
- F – Fridge
- PES – Private enclosed space
- M&E – Mechanical & Electrical
- CTL – Control Lift Panel
- ⊗ – Void

Units may have different columns in the basement (refer to BP Plan). All areas are inclusive of air-con ledge, open roof terrace, open to sky terrace, PES and void, if any. Furniture are indicative only and not provided. All plans are subject to amendment as approved by the relevant authorities. Floor areas are approximate measurements only and are subject to final survey.

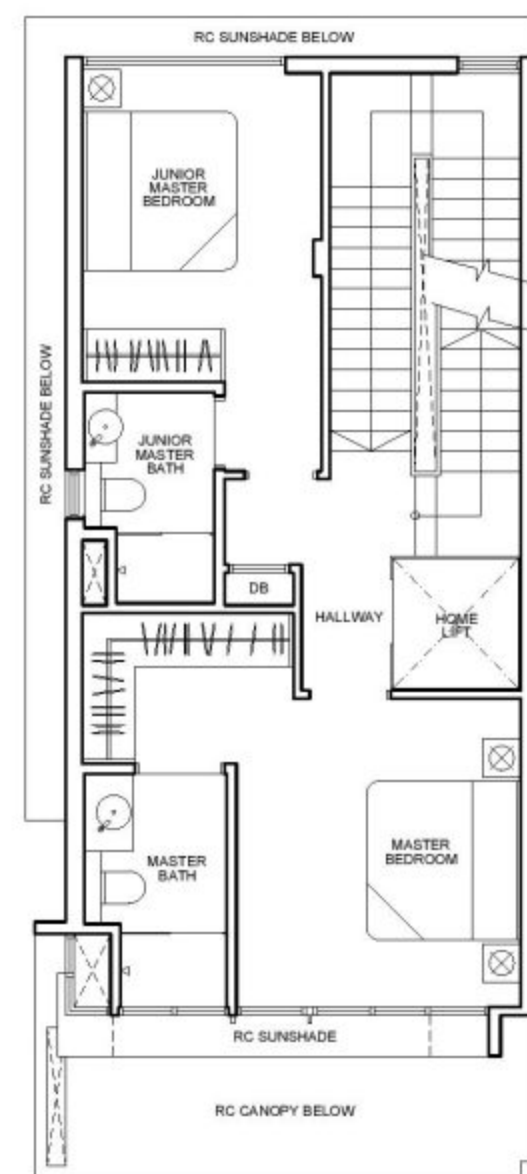
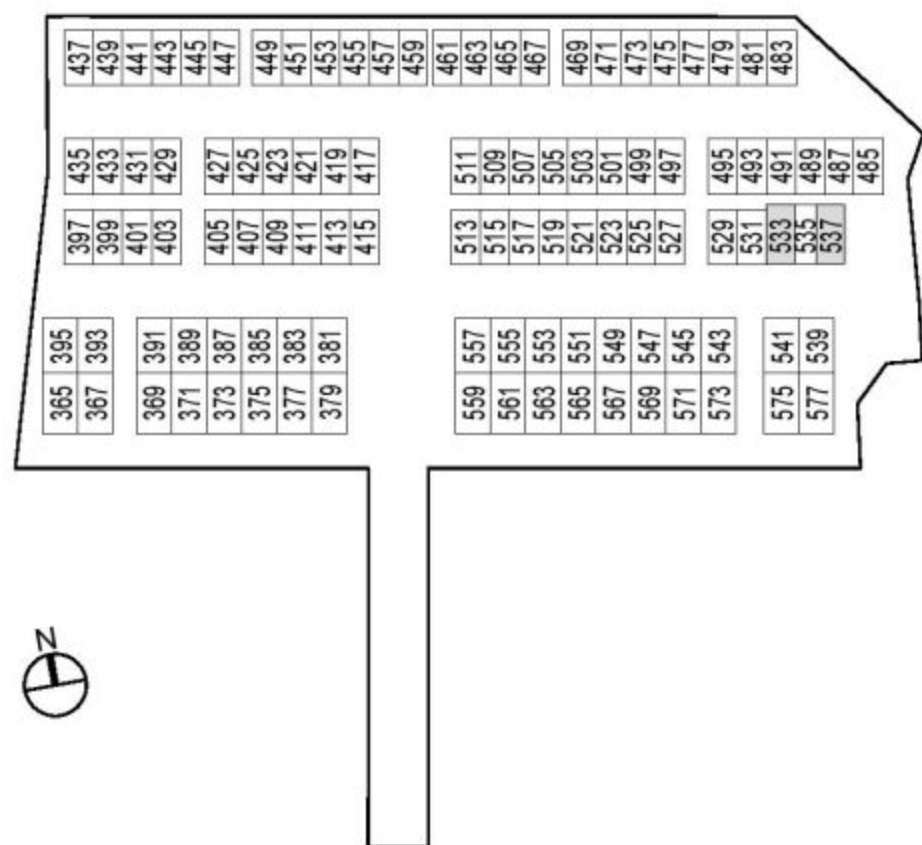

2ND STOREY

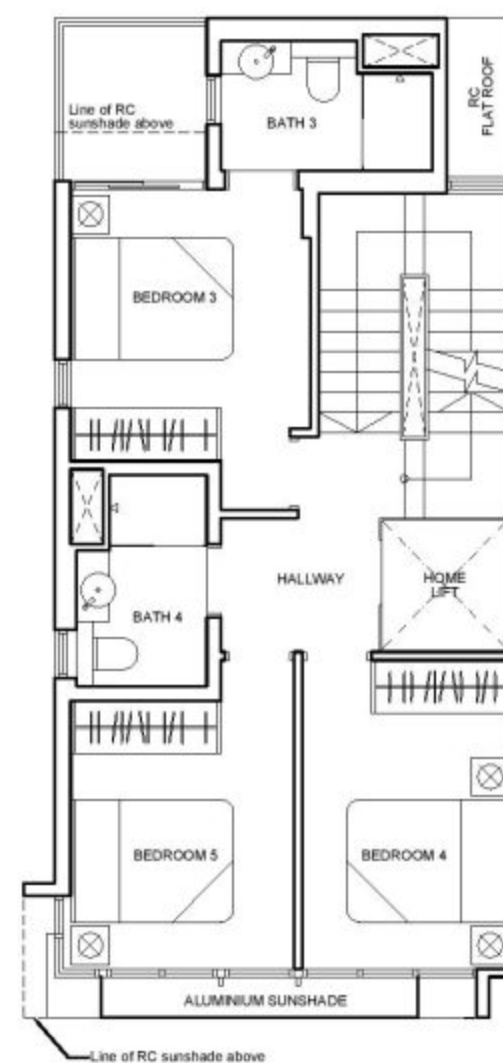

3RD STOREY



ROOF TERRACE

