

Floor Plan

TYPE SH2
7 sq.m. / 75 sq.ft.
Unit #01-02

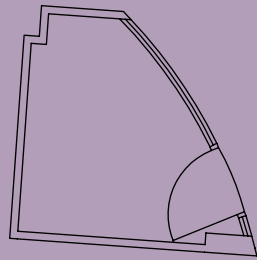

TYPE SH5
41 sq.m. / 441 sq.ft.
Unit #01-05

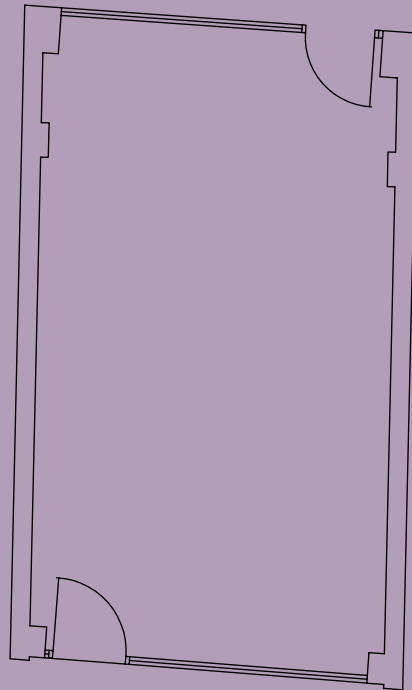

TYPE R3
65 sq.m. / 700 sq.ft.
Unit #01-03

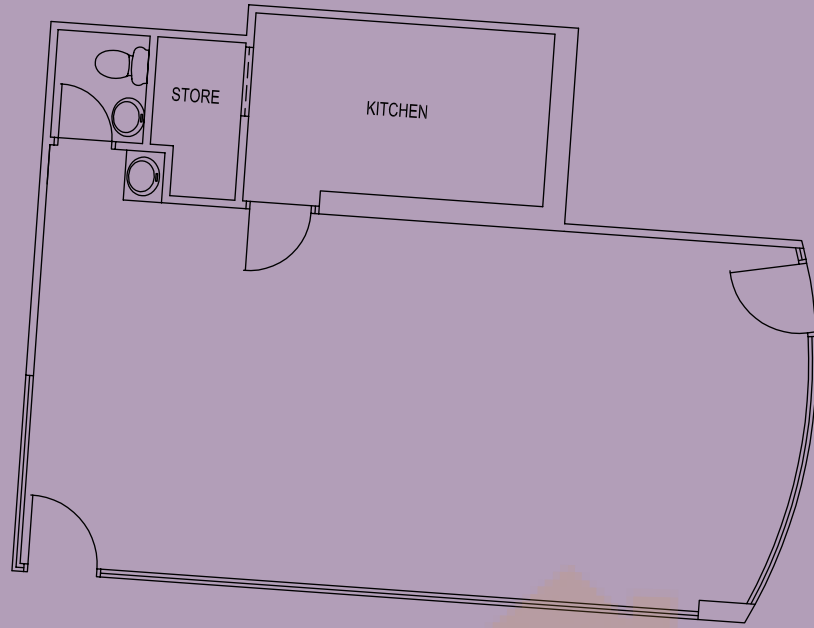

TYPE SH4
41 sq.m. / 441 sq.ft.
Unit #01-04

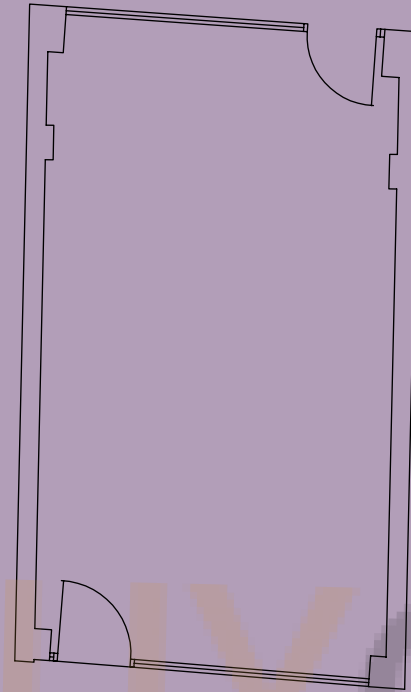

TYPE SH7
39 sq.m. / 420 sq.ft.
Unit #01-07

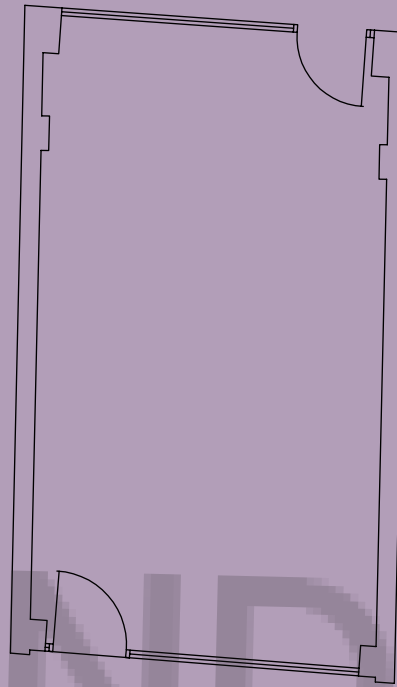

TYPE SH8
39 sq.m. / 420 sq.ft.
Unit #01-08

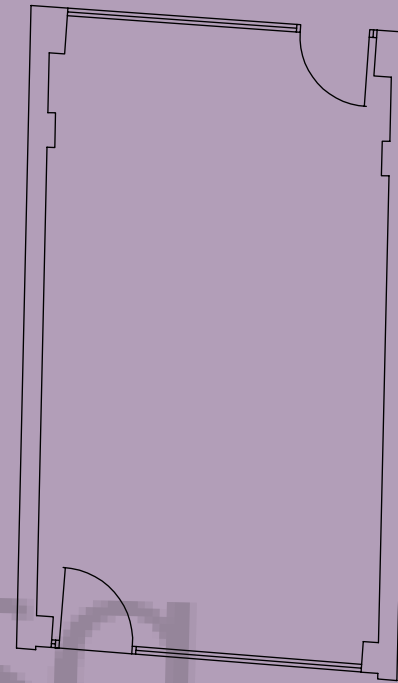

TYPE SH9
39 sq.m. / 420 sq.ft.
Unit #01-09

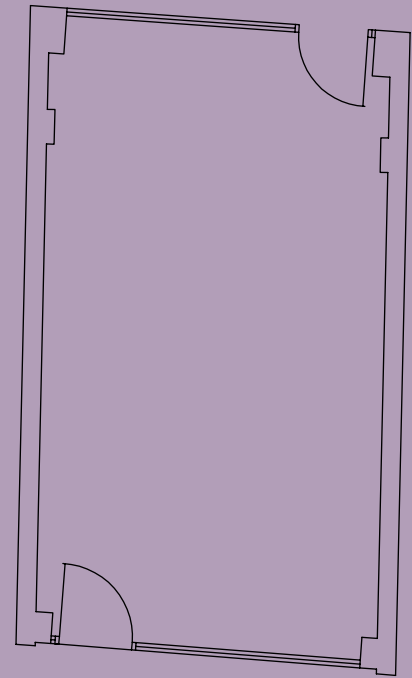

TYPE SH6
40 sq.m. / 431 sq.ft.
Unit #01-06

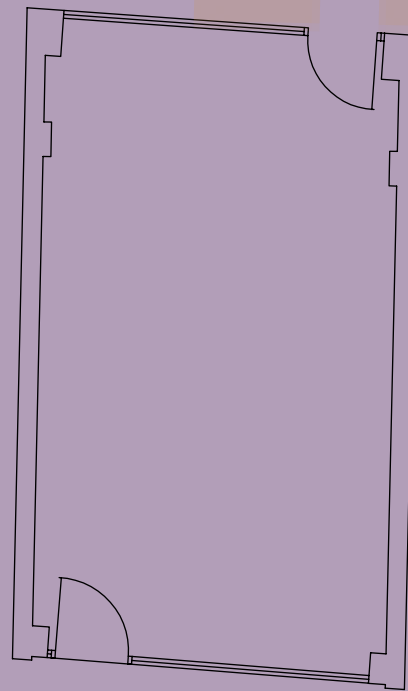

TYPE SH10
38 sq.m. / 409 sq.ft.
Unit #01-10

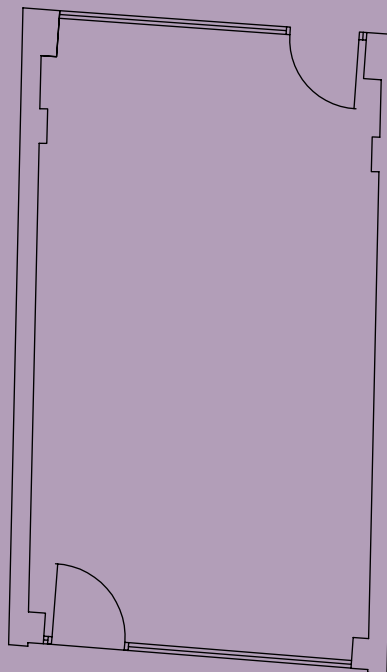

TYPE SH11
38 sq.m. / 409 sq.ft.
Unit #01-11

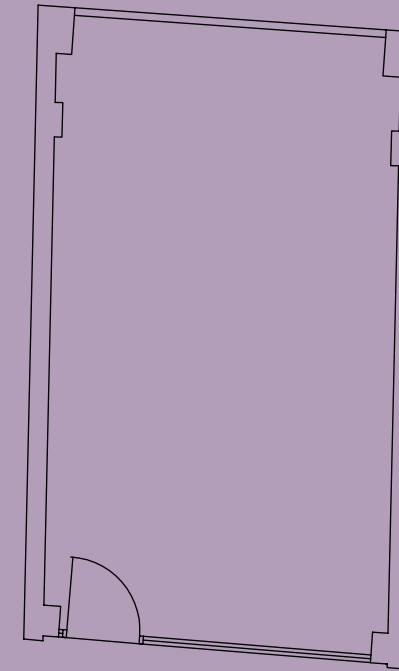

TYPE SH16
11 sq.m. / 118 sq.ft.
Unit #01-16

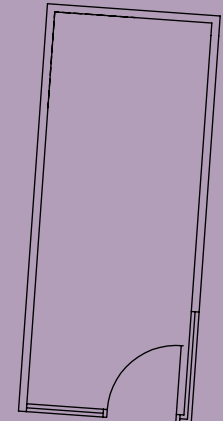

COMMERCIAL

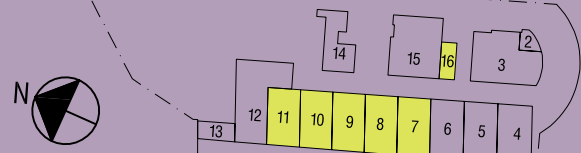
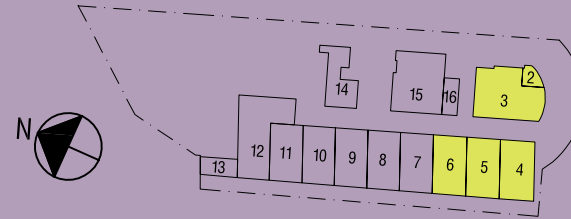

All areas stated herein include Strata Voids and Balconies where applicable. All areas and measurements stated herein are approximate and subject to adjustment on final survey. All plans are not to scale and subject to amendment as approved by the relevant authorities.

All areas stated herein include Strata Voids and Balconies where applicable. All areas and measurements stated herein are approximate and subject to adjustment on final survey. All plans are not to scale and subject to amendment as approved by the relevant authorities.

TYPE R12
67 sq.m. / 721 sq.ft.
Unit #01-12

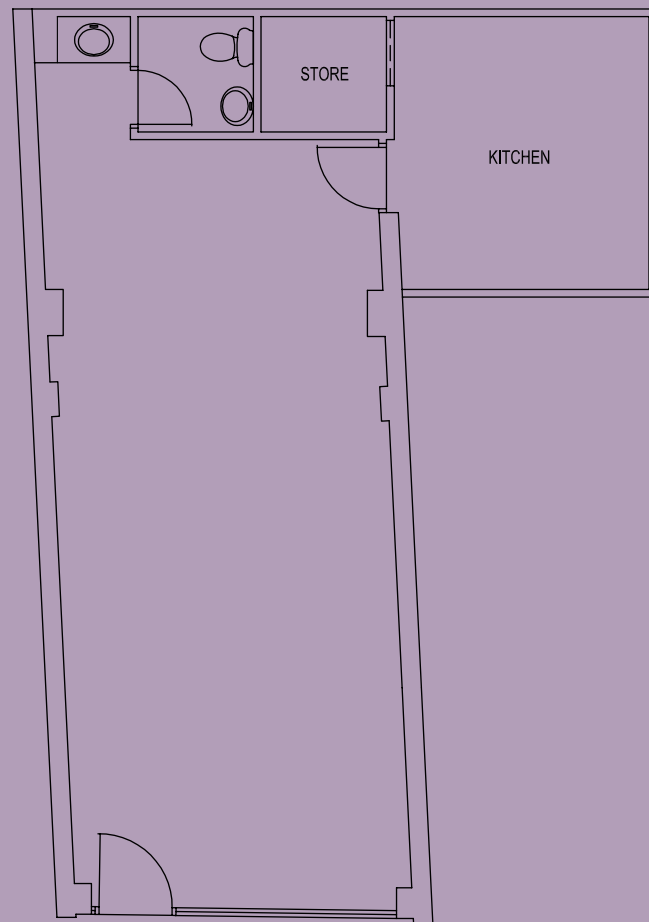

TYPE R14
31 sq.m. / 334 sq.ft.
Unit #01-14

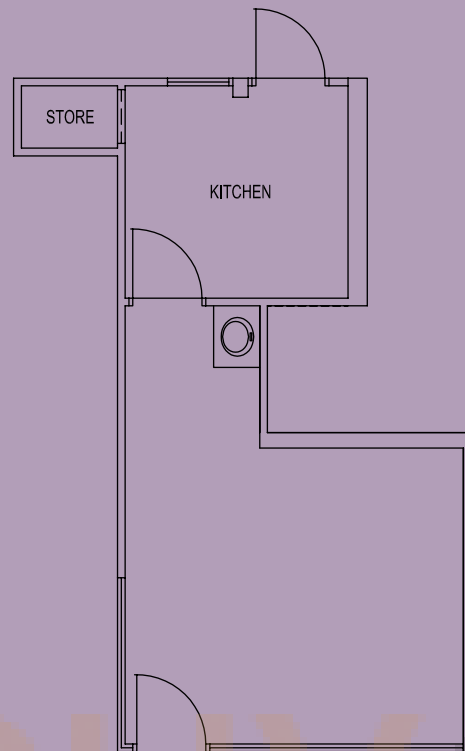

TYPE R15
63 sq.m. / 678 sq.ft.
Unit #01-15

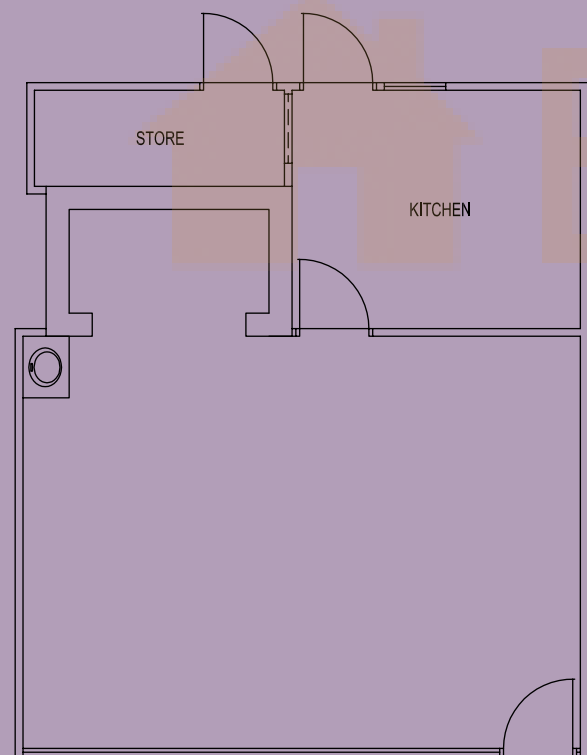

TYPE SH13
13 sq.m. / 140 sq.ft.
Unit #01-13

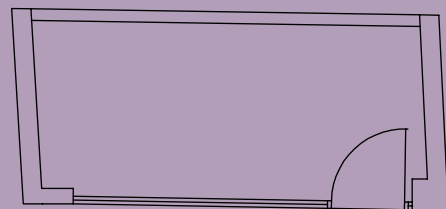

TYPE SH18
100 sq.m. / 1076 sq.ft.
Unit #02-02

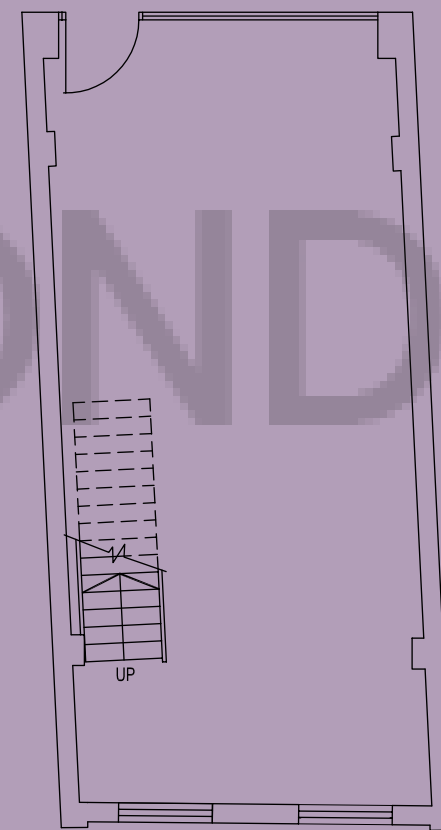

TYPE SH19
100 sq.m. / 1076 sq.ft.
Unit #02-03

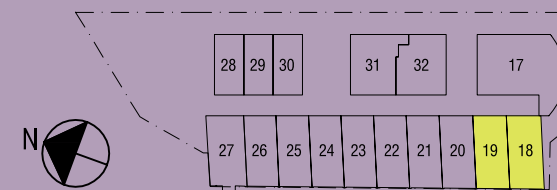
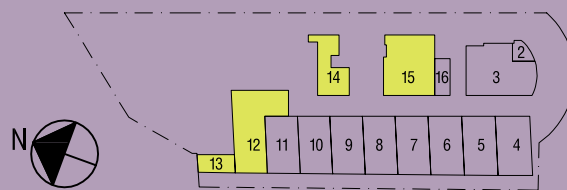
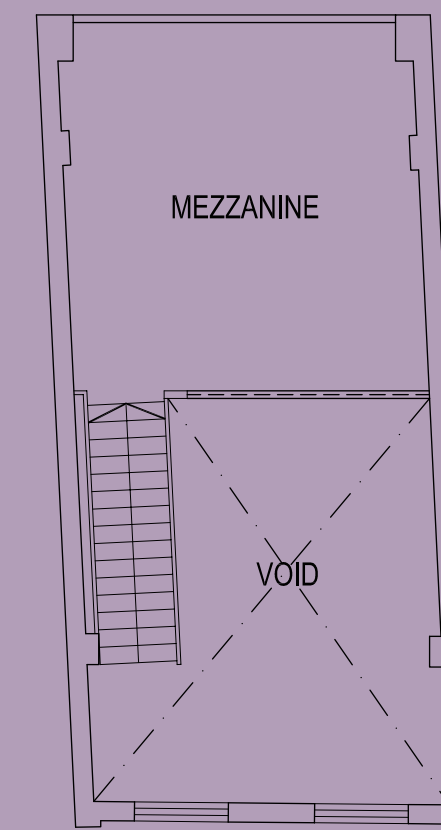
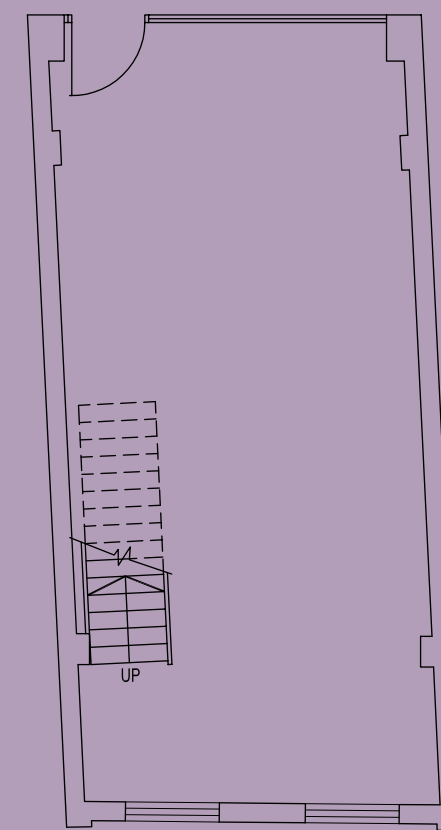

TYPE SH20

100 sq.m. / 1076 sq.ft.

Unit #02-04

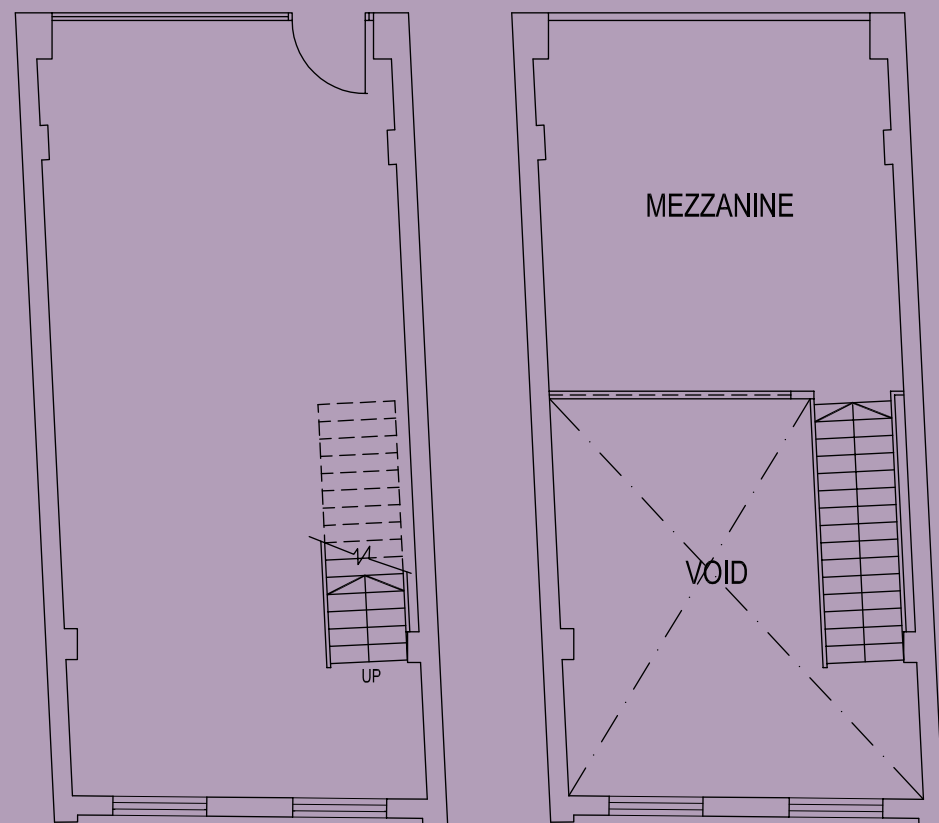

TYPE SH21

98 sq.m. / 1055 sq.ft.

Unit #02-05

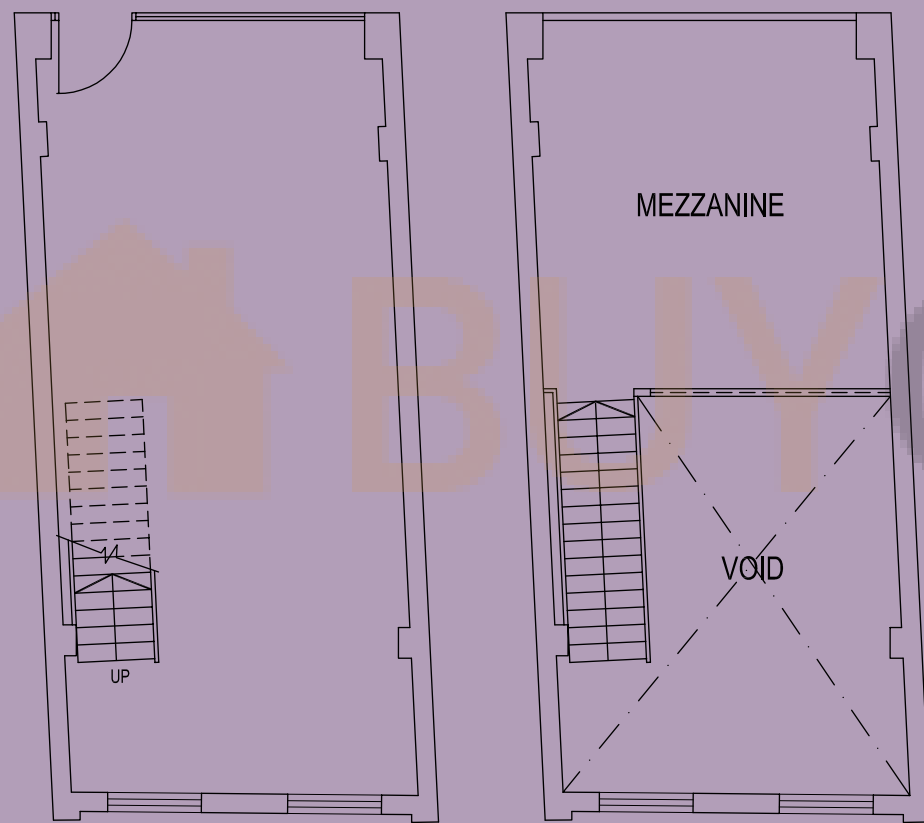

TYPE SH22

96 sq.m. / 1033 sq.ft.

Unit #02-06

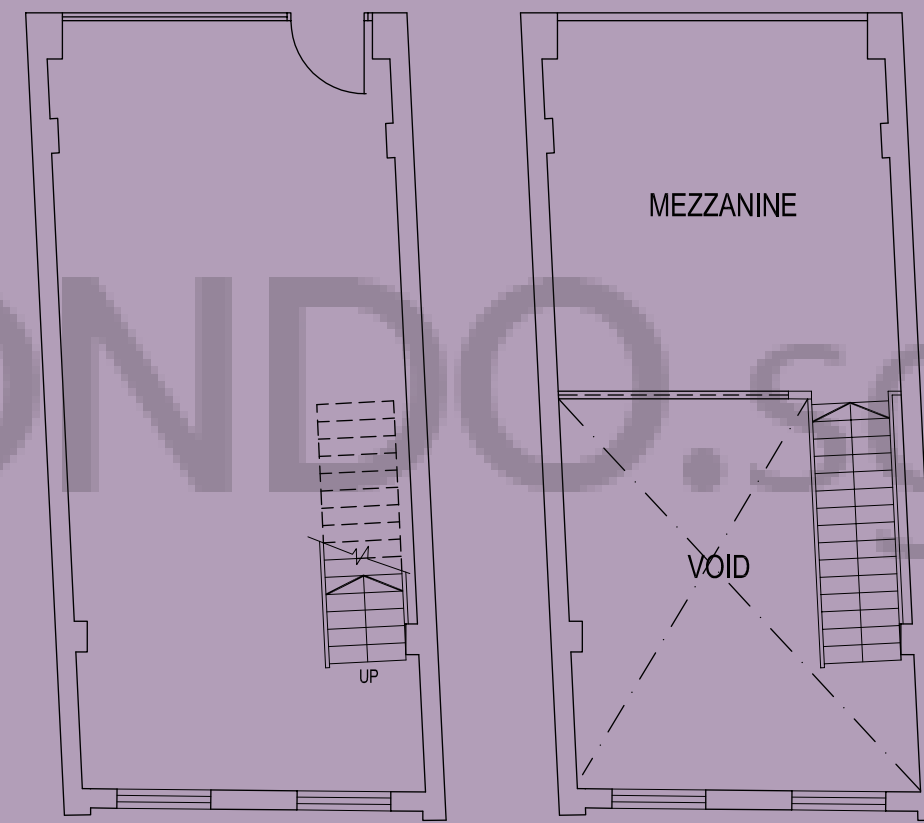

TYPE SH23

96 sq.m. / 1033 sq.ft.

Unit #02-07

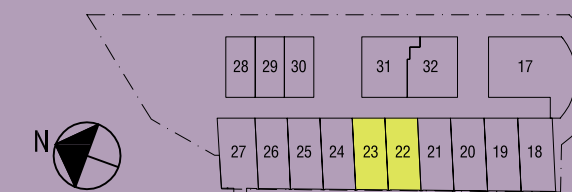
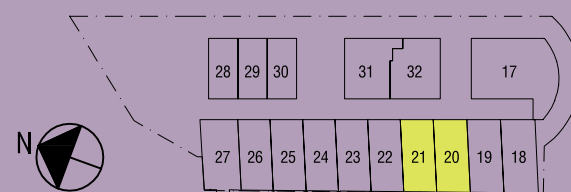
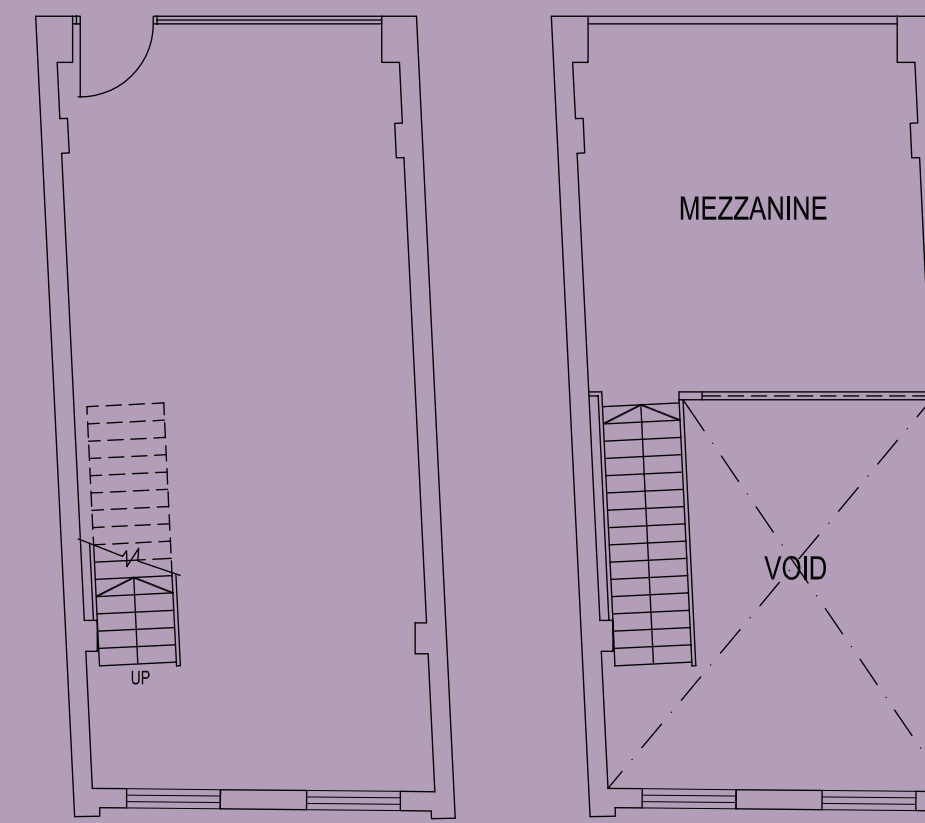

TYPE SH24
 94 sq.m. / 1012 sq.ft.
 Unit #02-08

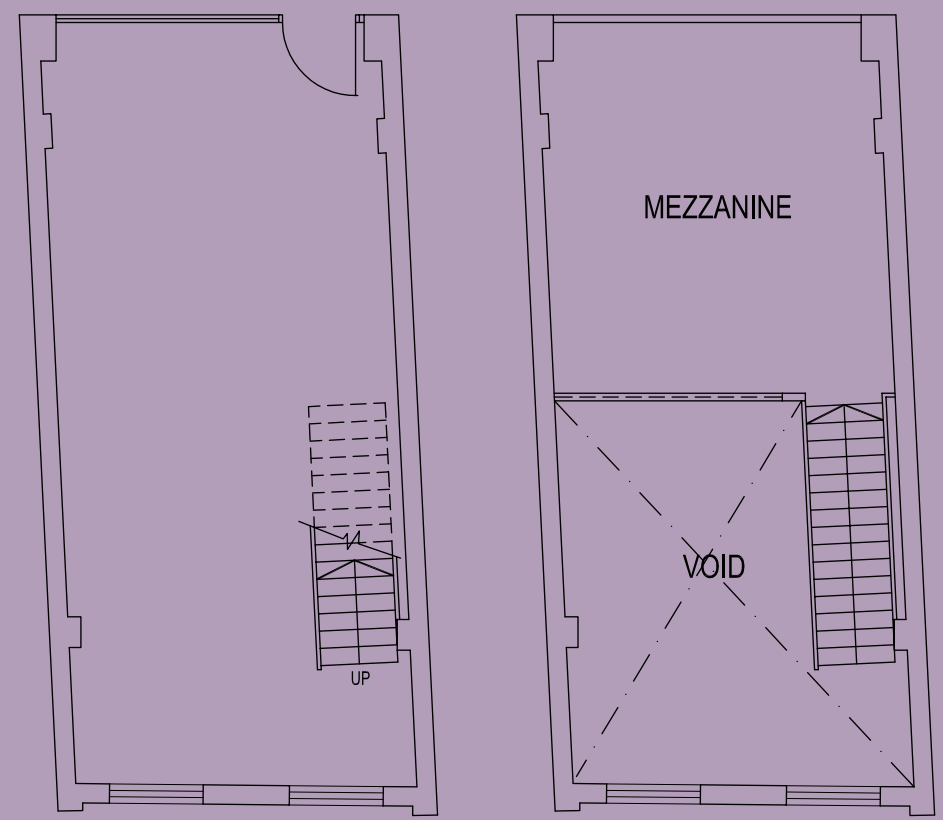

TYPE SH25
 96 sq.m. / 1033 sq.ft.
 Unit #02-09

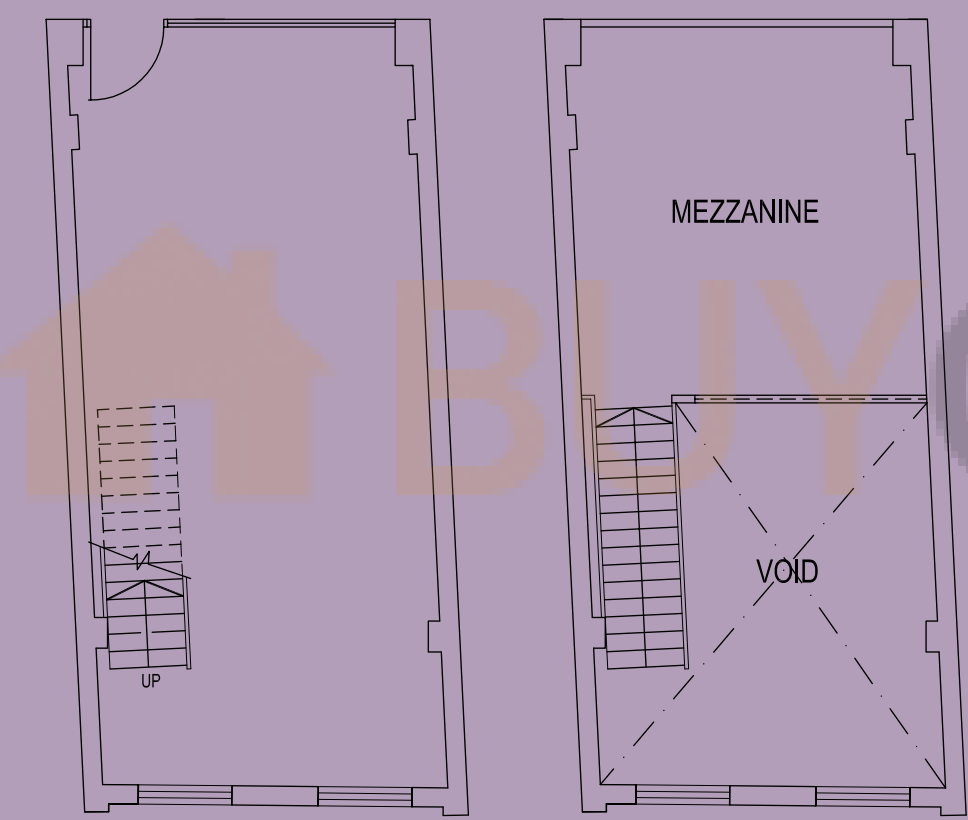

TYPE SH26
 92 sq.m. / 990 sq.ft.
 Unit #02-10

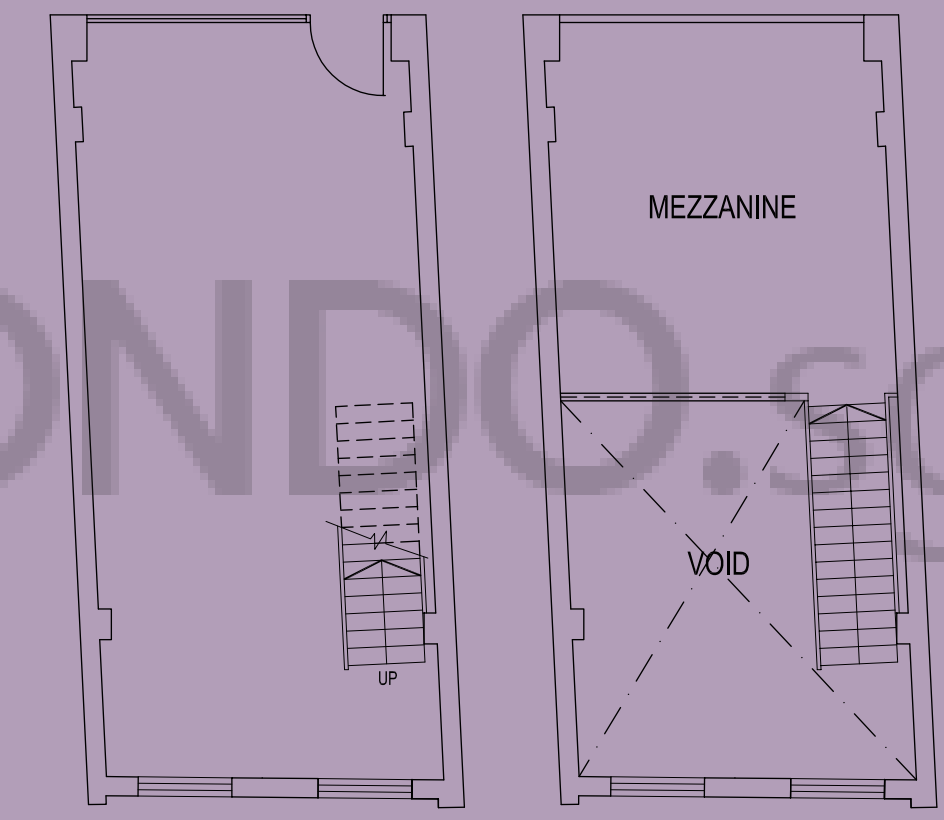

TYPE SH27
 108 sq.m. / 1163sq.ft.
 Unit #02-11

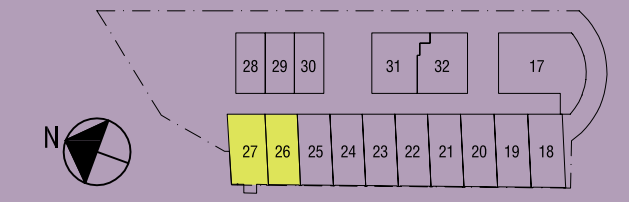
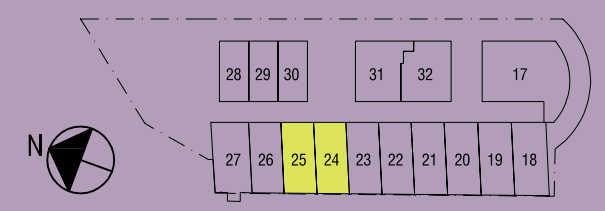
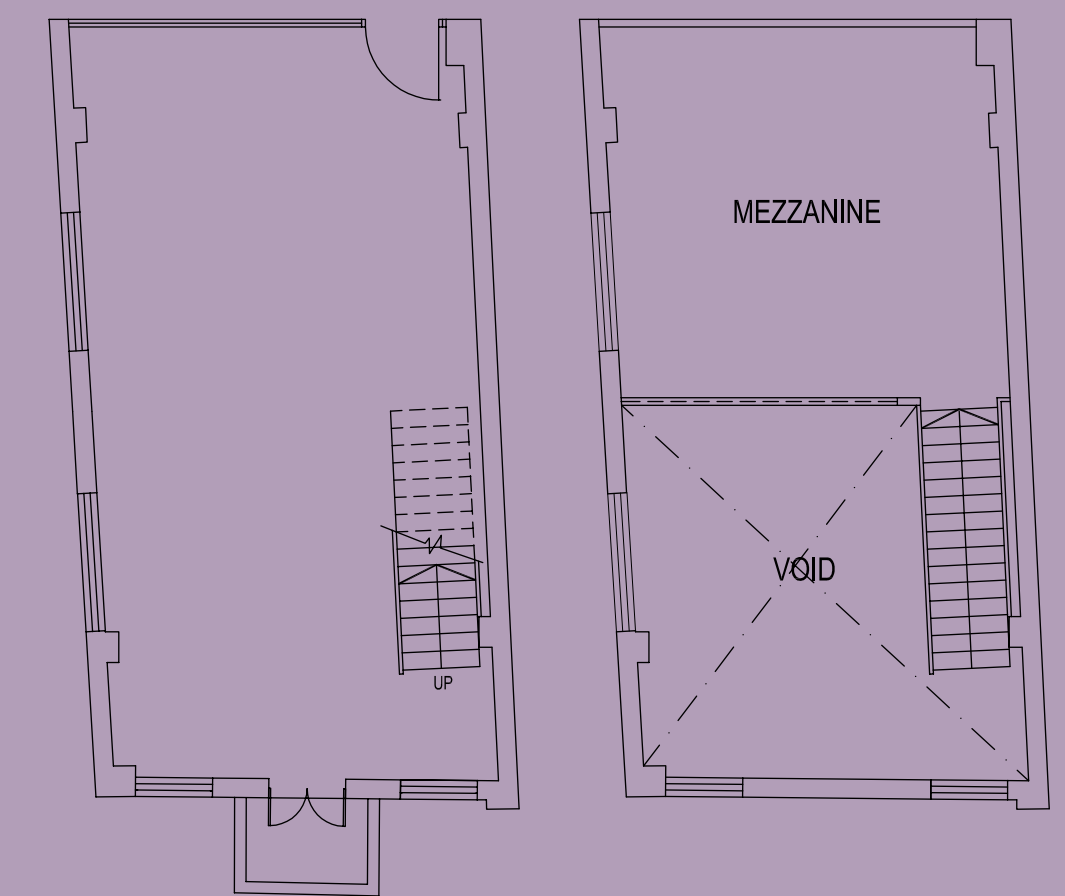

TYPE SH28
36 sq.m. / 388 sq.ft.
Unit #02-12

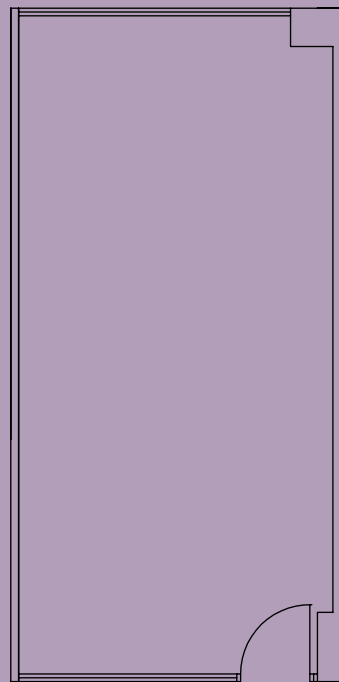

TYPE SH29
36 sq.m. / 388 sq.ft.
Unit #02-13

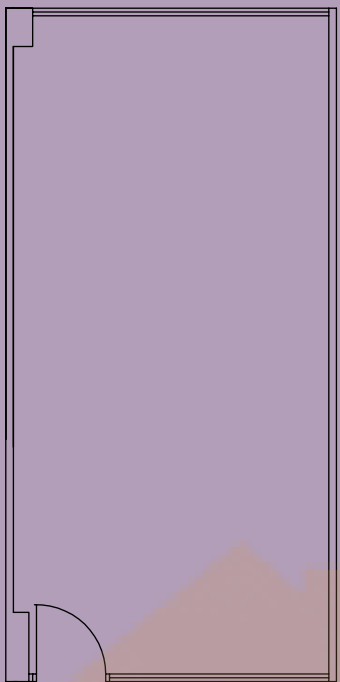

TYPE SH30
37 sq.m. / 398 sq.ft.
Unit #02-14

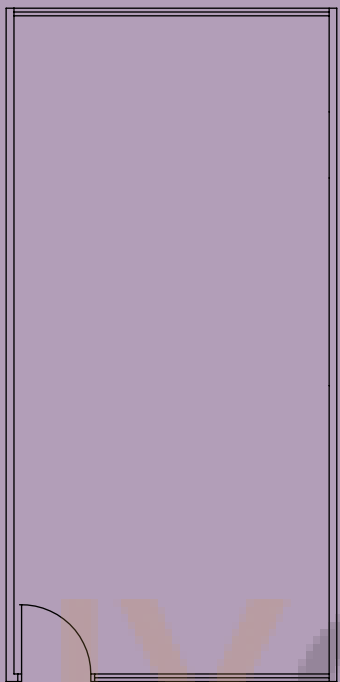

TYPE SH32
59 sq.m. / 635 sq.ft.
Unit #02-16

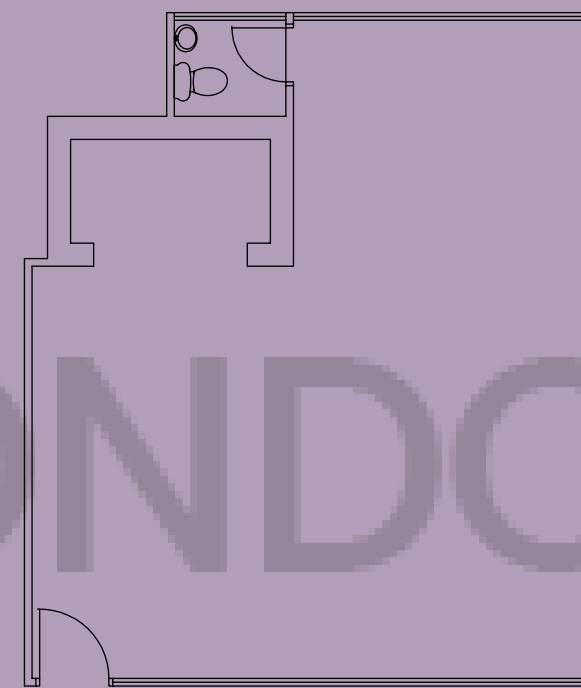

TYPE R17
124 sq.m. / 1335 sq.ft.
Unit #02-01

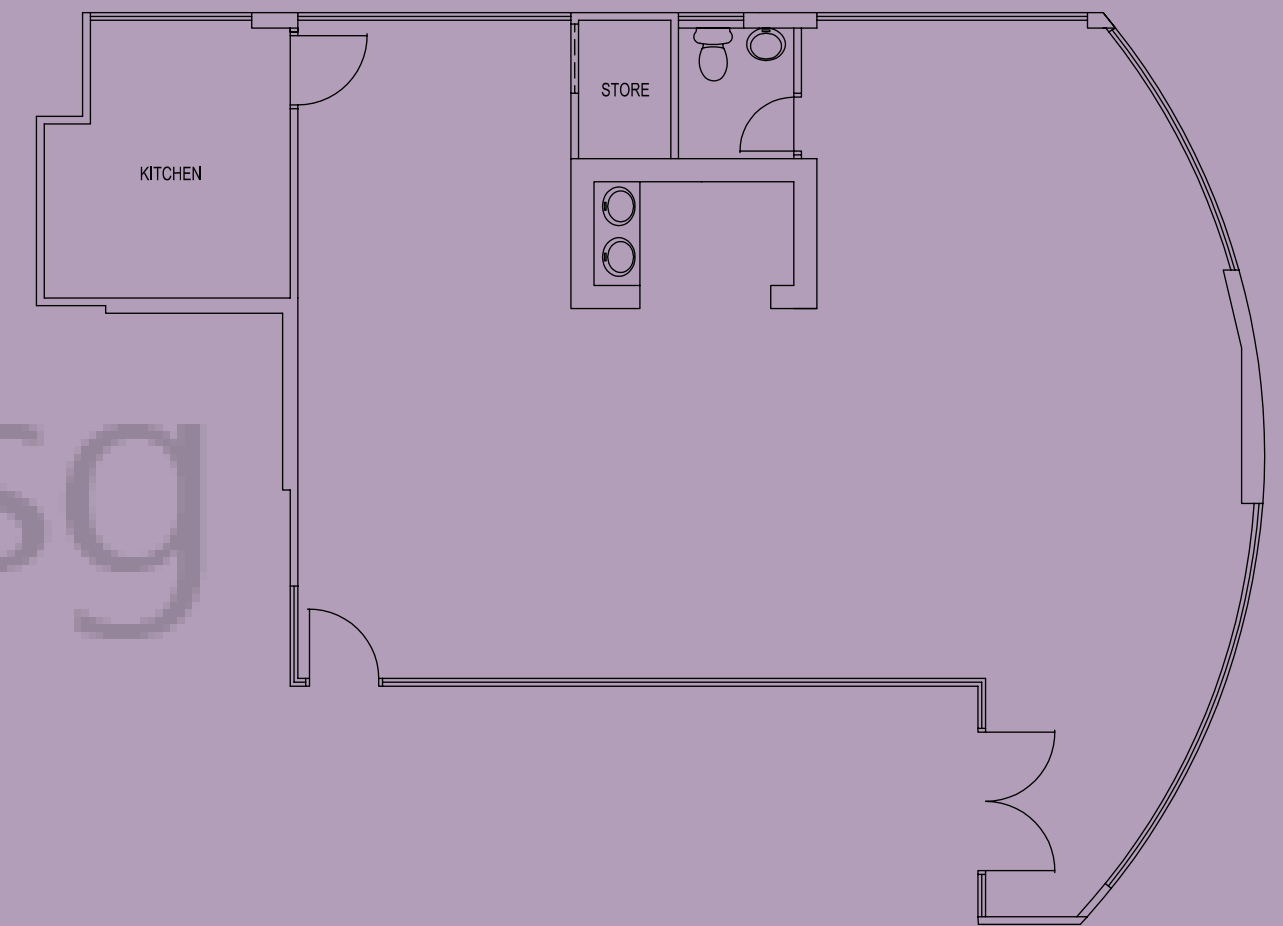

TYPE SH31
60 sq.m. / 646 sq.ft.
Unit #02-15

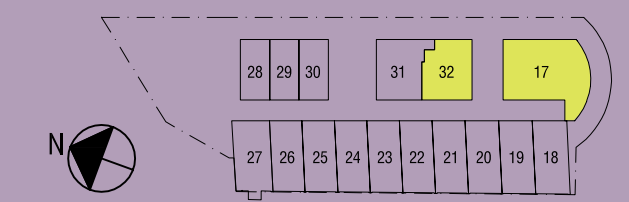
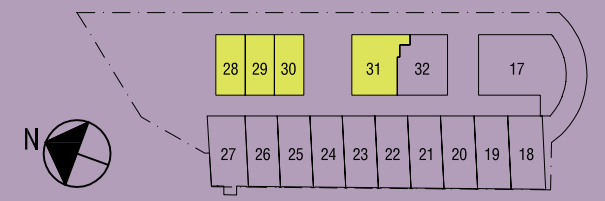
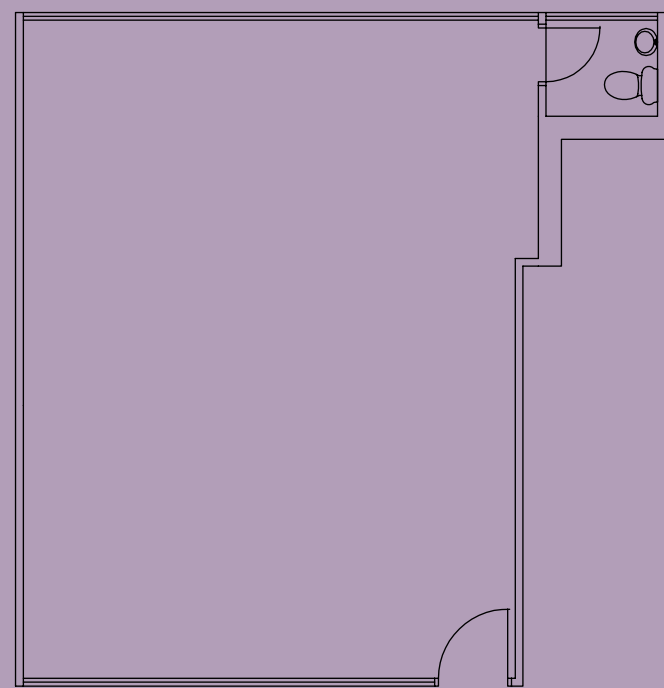

Floor Plan

RESIDENTIAL

TYPE A (2-Bedroom)
 53 sq.m. / 570 sq.ft.
 Unit #03-01, #04-01

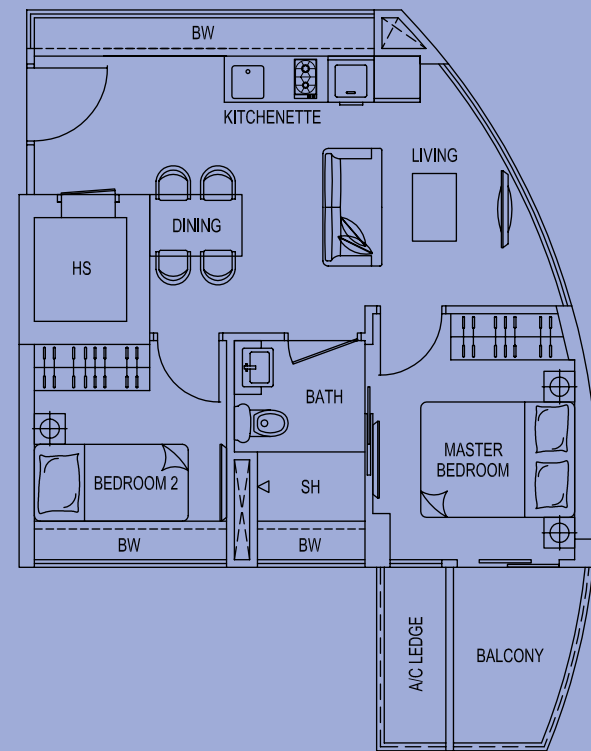

TYPE B (1-Bedroom)
 34 sq.m. / 366 sq.ft.
 Unit #03-02, #04-02

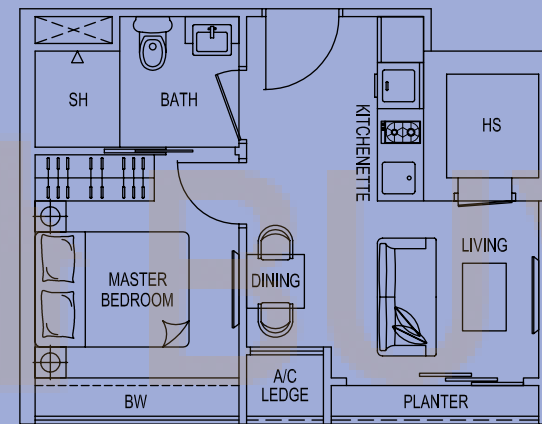

TYPE C (2-Bedroom)
 42 sq.m. / 452 sq.ft.
 Unit #03-03, #04-03, #05-03

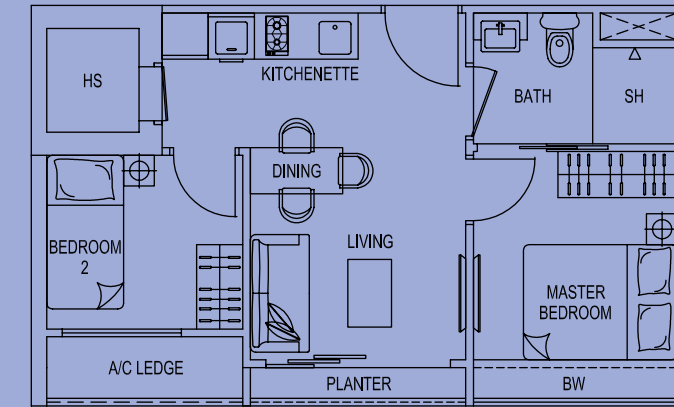

TYPE D (2-Bedroom)
 42 sq.m. / 452 sq.ft.
 Unit #03-04, #04-04, #05-04

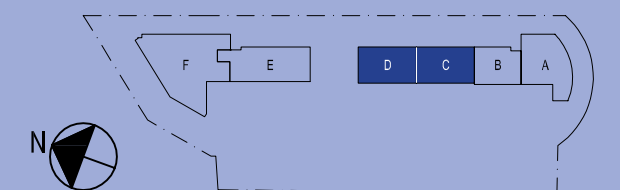
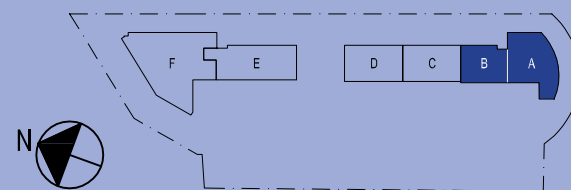
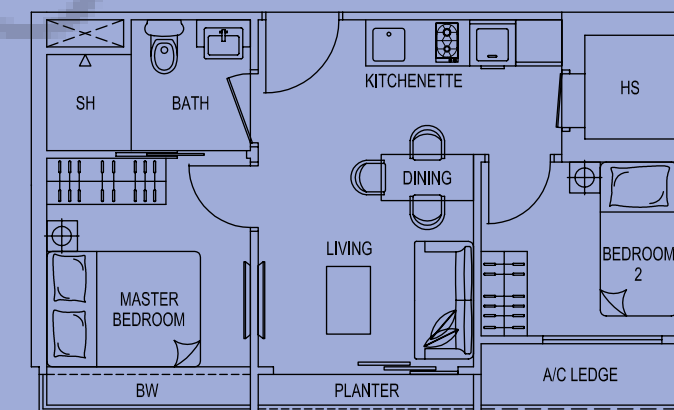

TYPE E (2-Bedroom)

56 sq.m. / 603 sq.ft.

Unit #03-05, #04-05

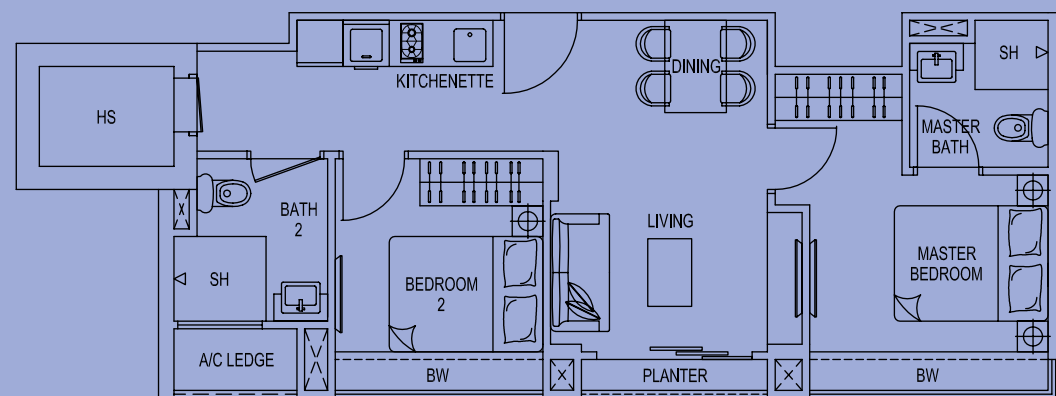

TYPE A1 (2-Bedroom Penthouse)

108 sq.m. / 1163 sq.ft.

Unit #05-01

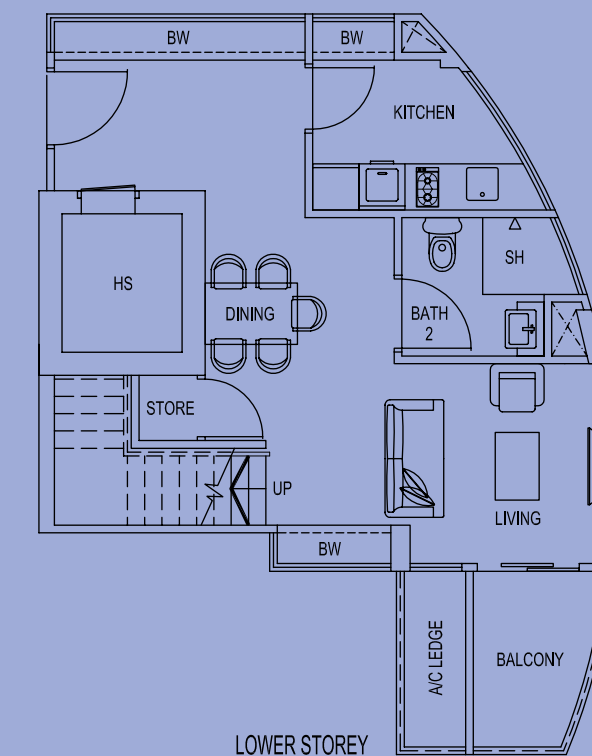

TYPE F (3-Bedroom)

96 sq.m. / 1033 sq.ft.

Unit #03-06, #04-06

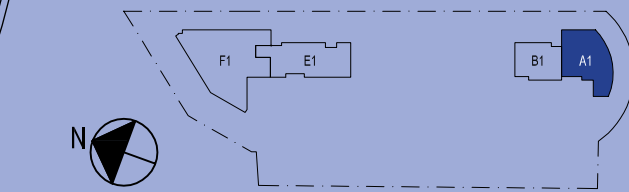
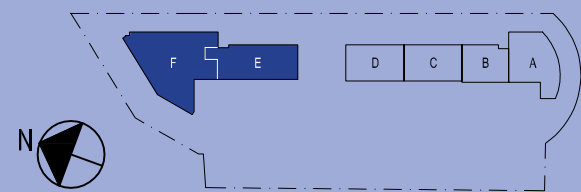
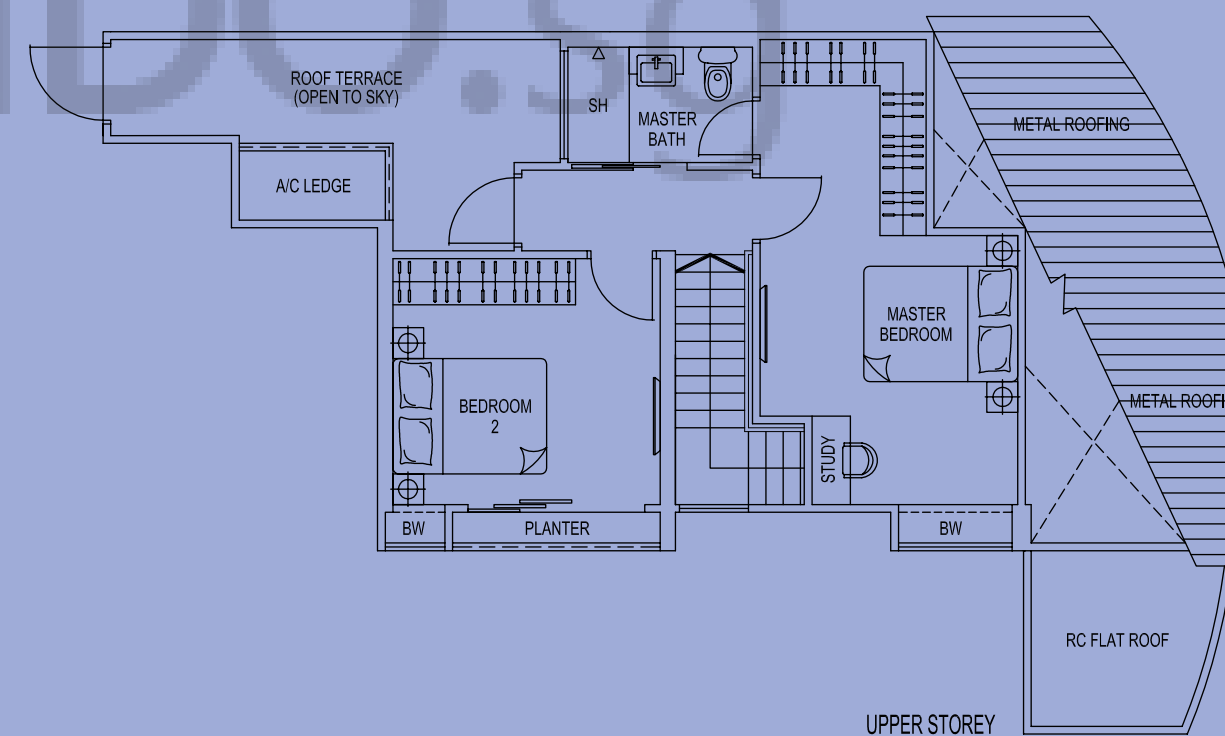
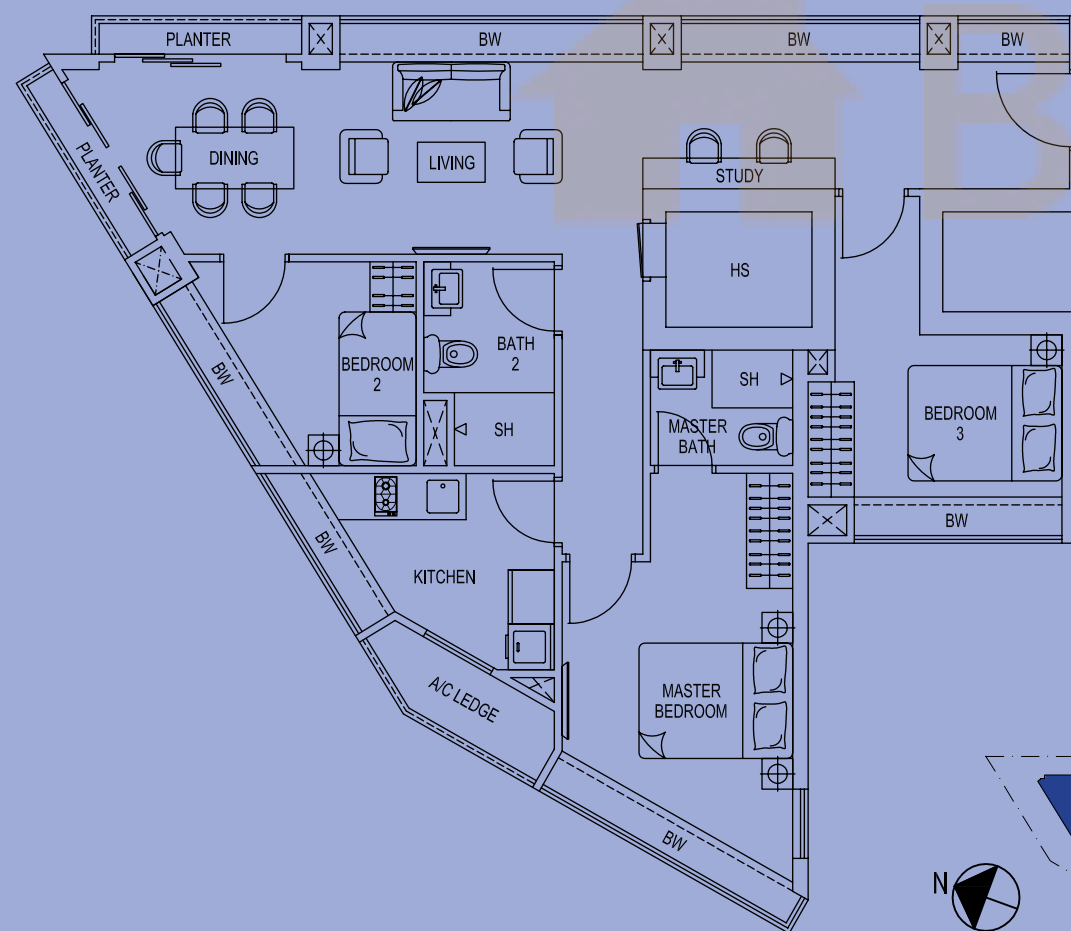

TYPE B1 (2-Bedroom Penthouse)

79 sq.m. / 850 sq.ft.

Unit #05-02

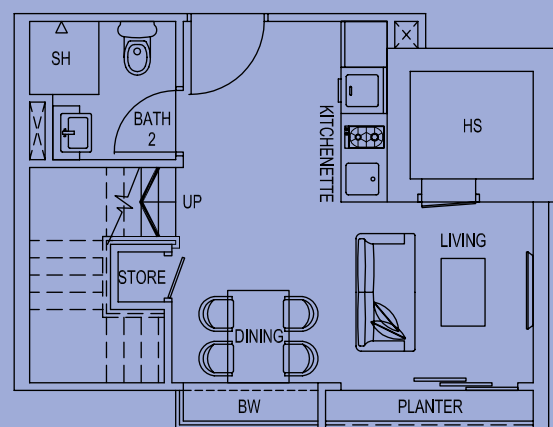

LOWER STOREY

TYPE E1 (3-Bedroom Penthouse)

90 sq.m. / 969 sq.ft.

Unit #05-05

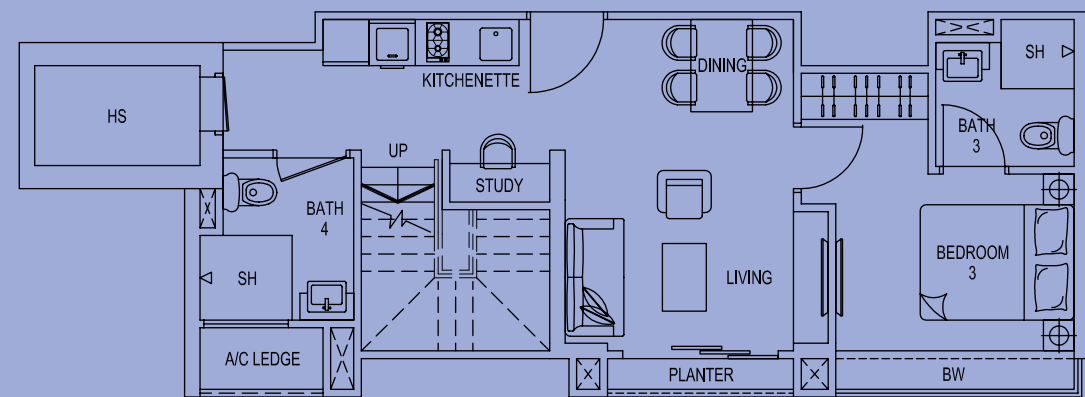

LOWER STOREY

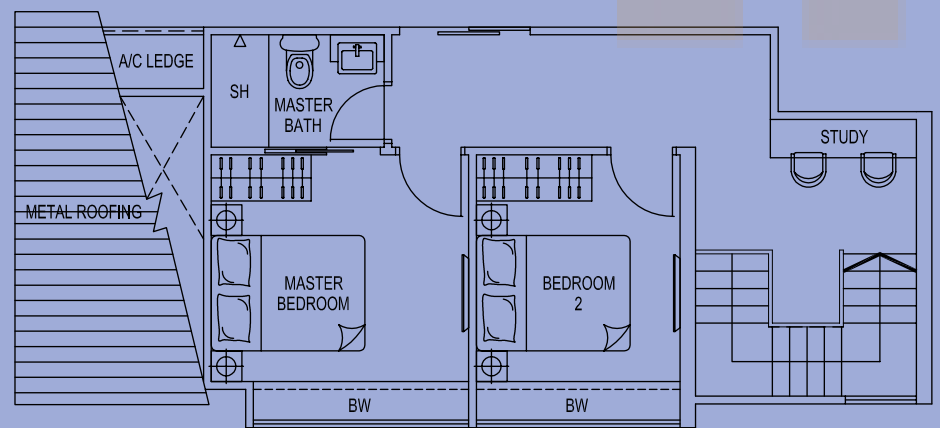

UPPER STOREY

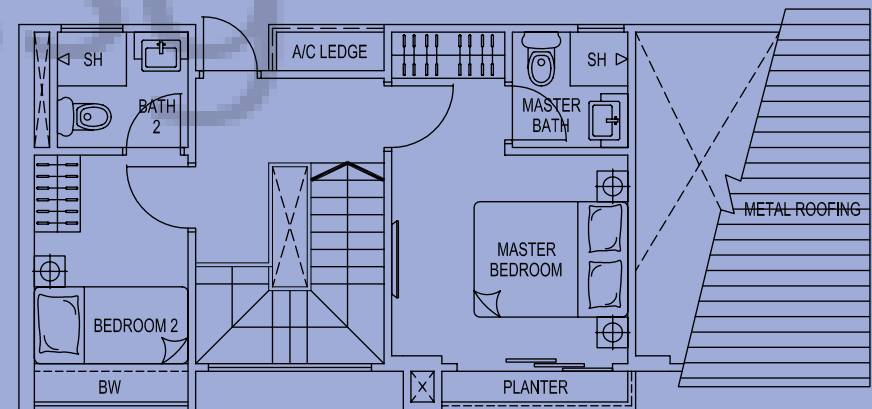

UPPER STOREY

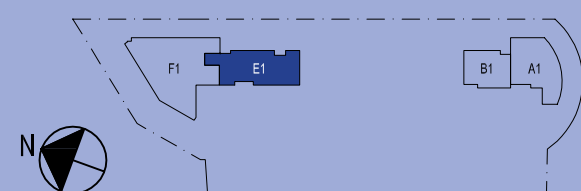
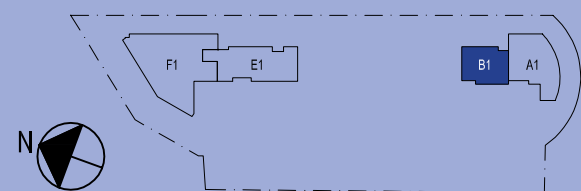

Specifications

TYPE F1 (5-Bedroom Penthouse)

166 sq.m. / 1787 sq.ft.

Unit #05-06



All areas stated herein include A/C Ledges, Planter Boxes, Balconies, Roof Terraces and/or Bay Windows where applicable. All areas and measurements stated herein are approximate and subject to adjustment on final survey. All plans are not to scale and subject to amendment as approved by the relevant authorities.

- Foundation**
Raft foundation with 650mm thick reinforced concrete slab
- Superstructure**
Reinforced concrete using Grade 35 and/ or Grade 45 concrete complying with SS26 and steel reinforcement bars complying with SS22
- Walls**
a) External wall – RC walls and/ or clay bricks
b) Internal wall – Clay bricks and/ or pre-cast concrete panel
- Roof**
a) Flat roof: Reinforced concrete roof with appropriate water proofing system
b) Metal roof: Insulated roofing system
- Ceiling**
Apartment Units
Living/ Dining, Bedroom, Kitchen, Kitchenette, Bath, Balcony and Planter : False ceiling
Store and Household Shelter : Skim coat with emulsion paint

Common Areas
Lift Lobbies, Escape Staircases, Basement Mechanized Car Parks and Other Areas : False ceiling and/ or Skim coat with emulsion paint
- Finishes**
a) *Walls*
i) *Apartment Units*
Living/ Dining, Bedroom, Kitchen, Kitchenette, Balcony, Roof Terrace, Store and Household Shelter : Cement and sand plaster/ skim coat with emulsion paint up to ceiling height or exposed areas only
Bath : Ceramic and/ or homogeneous tiles laid up to false ceiling level
ii) *Common Areas*
Internal Walls
Lift Lobbies : Homogeneous tiles at lift entrance area
Other Areas
 : Cement and sand plaster/ skim coat with emulsion paint up to ceiling height
External Walls
All Areas : Cement and sand plaster/ skim coat
b) *Floors*
i) *Apartment Units*
Internal Floors
Living/ Dining and Kitchenette : Marble with skirting
Kitchen, Bath, Household Shelter, Balcony, Store and Roof Terrace : Homogeneous and/ or ceramic tiles
Private Staircase and Bedroom : Timber strips with skirting
ii) *Common Areas*
Internal Floors
Lift Lobbies : Homogeneous and/ or ceramic tiles
Escape Staircases and Other Areas : Cement/sand screed and/ or ceramic tiles
External Floors
Other Areas : Cement/ sand screed and/ or ceramic tiles
- Windows**
Powder-coated aluminium and/ or UPVC framed windows with tinted and/ or tempered glass to all areas except for Bath using frosted glass (where applicable)
- Doors**
a) Approved fire-rated timber swing door with veneer finished to Main Entrance
b) Timber swing and/ or sliding door with veneer finished to all Bedroom and Bath
c) Powder coated aluminium and/ or UPVC framed glass door from Bedroom/ Living/ Dining to Balcony/ Planter/ Roof Terrace where applicable
d) Metal gate from Roof Terrace to Common Area where applicable
e) Light steel protective door according to Competent Authority's requirement to Household Shelter
f) Imported good quality ironmongery provided to doors
- Sanitary Fittings**
Bath : One shower cubicle with shower mixer & soap holder
 : Granite vanity top with one wash basin and tap mixer
 : One pedestal water closet
 : One mirror
 : One paper holder
 : One towel rail
- Electrical Installation**
a) Refer to Electrical Schedule for details
b) All electrical wirings are concealed in conduits/trunkings wherever possible
- TV/ FM/ Telephone**
Refer to Electrical Schedule for details
- Lightning Protection**
Lightning protection system shall be provided in accordance with Singapore Standard CP
- Painting**
a) Internal walls and ceiling : Emulsion paint
b) External walls : Sprayed textured coating and/ or emulsion paint
- Water Proofing**
Water proofing to floor slab of Kitchen, Kitchenette, Bath, Balcony, Planter, Roof Terrace and Reinforced Concrete Roof where applicable
- Driveway and Car Park**
Homogeneous tiles or cement/sand screed to driveway of mechanized car park

- Recreation Facilities**
a) Outdoor Children's Playground
b) Gymnasium
c) BBQ Area
 - Additional Items**
a) Kitchen Cabinets and Appliances : Solid surface countertop complete with veneer plywood kitchen cabinets, kitchen sink with mixer, electric induction hob, electric hood and built-in electric microwave oven to all unit types
b) Bedroom Wardrobe : Built-in wardrobe complete with aluminium sliding glass door to all Bedroom
c) Air-conditioners : i) One ceiling-mounted air-conditioning system provided to Living/ Dining Area
 : ii) One wall-mounted air-conditioning system provided to Bedrooms of all unit types
d) Hot Water Provision : Hot water supply provided to every Bath
e) Mechanical Ventilated Exhaust Fan : Mechanical ventilated exhaust fan system provided to Powder Room and Bath according to the Competent Authority's requirements
f) Intercom System : i) Card-accessed system to residential lobby and side entrance
 : ii) Audio intercom system provided to each unit, linking to residential lobby and side entrance
g) Fire Sprinkler System : Fire sprinkler system provided to basement mechanized car parks
h) Balcony and Roof Terrace : RC parapet wall and/ or tempered & laminated glass with polished stainless steel hand railing
i) Balcony and Roof Terrace : One tap provided
- Note:
- Marble/ Granite**
Marble/granite are natural stone materials containing veins with tonality differences. There will be colour and markings caused by their complex mineral composition and incorporated impurities. While such materials can be pre-selected before installation, this non-conformity in the marble/granite as well as non-uniformity between pieces cannot be totally avoided. Granite tiles are pre-polished before laying and care has been taken for their installation. However, granite, being a much harder material than marble, cannot be re-polished after installation. Hence, some differences may be felt at the joints. Subject to clause 14.3, the tonality and pattern of the marble or granite selected and installed shall be subject to availability.
 - Timber strips**
Timber strips are natural materials containing veins and tonal differences. Thus, it is not possible to achieve total consistency of colour and grain in their selection and installation. Timber strips are also subject to thermal expansion and contraction beyond the control of builder and vendor. Natural timber that is used outdoors will become bleached due to sunlight and rain. Thus, the cycle of maintenance on staining will need to be increased as required. Notwithstanding this note, the Vendor shall remain fully responsible for the performance of its obligations under clause 9 and clause 17.
 - Air-conditioning system**
To ensure good working condition of the air-conditioning system, the system has to be maintained and cleaned on a regular basis by the Purchaser. This includes the cleaning of filters, clearing of condensate pipes and charging of gas. The Purchaser is advised to engage his/her own contractor to service the air-conditioning system regularly.
 - Television and/ or Internet Access**
The Purchaser is liable to pay annual fee, subscription fee and such other fees to the television and/ or internet service providers or any other relevant party or any relevant authorities. The Vendor is not responsible to make arrangements with any of the said parties for the service connection for their respective channels and/ or internet access.
 - Materials, Fittings, Equipment, Finishes, Installations and Appliances**
Subject to clause 14.3, the brand, colour and model as specified for all materials, fittings, equipment, finishes, installations and appliances to be supplied shall be provided subject to Architect's selection and market availability.
 - Layout/ Location of Wardrobes, Cabinets, Fan Coil Units, Electrical Points, Television Points, Telecommunication Points, Audio Intercom System, Door Swing Positions and Plaster Ceiling Boards**
Layout/ Location of wardrobes, kitchen cabinets, fan coil units, electrical points, television points, telecommunication points, audio intercom system, door swing positions and plaster ceiling boards are subject to Architect's final decision and design.
 - Warranties**
Where warranties are given by the manufacturers and/ or contractors and/ or suppliers of any of the equipment and/ or appliances installed by the Vendor at the Unit, the Vendor will assign to the Purchaser such warranties at the time when vacant possession of the Unit is delivered to the Purchaser. Notwithstanding this assignment, the Vendor shall remain fully responsible for the performance of its obligations under clause 9 and clause 17.
 - Web Portal of the Housing Project**
The Purchaser will have to pay annual fee, subscription fee or any such fee to the service provider of the Web Portal of the Housing Project as may be appointed by the Vendor or the Management Corporation when it is formed.
 - False Ceiling**
The false ceiling space provision allows for the optimal function and installation of M&E services. Access panels are allocated for ease of maintenance access to concealed M&E equipment for regular cleaning purposes. Where removal of equipment is needed, ceiling works will be required. Location of false ceiling is subject to the Architect's sole discretion and final design.
 - Glass**
Glass is manufactured material that is not 100% pure. Invisible nickel sulphide impurities may cause spontaneous glass breakage, which may occur in all glass by all manufacturers. The Purchaser is recommended to take up home insurance covering glass breakage to cover this possible event. Notwithstanding this note, the Vendor shall remain fully responsible for the performance of its obligations under clause 9 and clause 17.
 - Mechanical Ventilation System**
Mechanical Ventilation fans and ductings are provided to toilets which are not naturally ventilated. To ensure good working condition of the mechanical ventilation system, the mechanical ventilation system for the exhaust system within internal toilets (where applicable) is to be maintained by the Purchaser on a regular basis.
 - Mechanised Car Parking System**
The mechanised car parking system has to be maintained regularly by the specialist to ensure that it is in good and proper working condition.
 - Planters**
Planters are designed to take the loading of potted plants only. No soil material or turf plants will be provided in the planters.
 - Wall**
All wall finishes shall be terminated at false ceiling level.
- While every reasonable care has been taken in preparing this brochure, the developer and its agents cannot be held responsible for any inaccuracies. All statements are believed to be correct but are not to be registered as statements or representations of facts. All information and specifications are current at the time of going to press and are subject to change as may be required and cannot form part of the contract. All plans are subject to any amendments approved by the relevant authority. Renderings, illustrations, building model and showflat displays are artist's impressions only and cannot be regarded as representation of fact. Floor areas are approximate measurements and subject to final survey. The Sale and Purchase Agreement shall form the entire agreement between the developer and the purchaser and shall in no way be modified by any statements or representations contained in the marketing materials or provided by the developer and/ or its agent(s) or otherwise.