

1-Bedroom
+ Study

Type A

57 sqm / 614 sqft

Blk 39 #02-04 to #04-04
Blk 45 #02-16 to #04-16

(Mirrored)

Blk 41 #02-10 to #04-10
Blk 43 #02-14 to #04-14

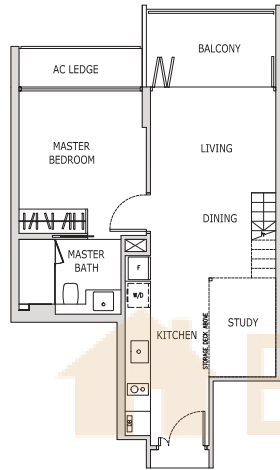

1-Bedroom
+ Study

Type A (p)

58 sqm / 624 sqft

Blk 39 #01-04
Blk 45 #01-16

(Mirrored)

Blk 41 #01-10
Blk 43 #01-14

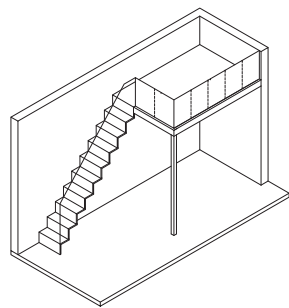

Isometric view of storage deck
Clear ceiling height of 3.3m

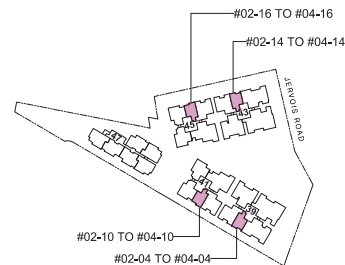

KEY PLAN
THIS KEY PLAN IS NOT TO SCALE

The above plan is subject to change as may be required or approved by the relevant authorities.
All floor areas are approximate and subject to final survey.

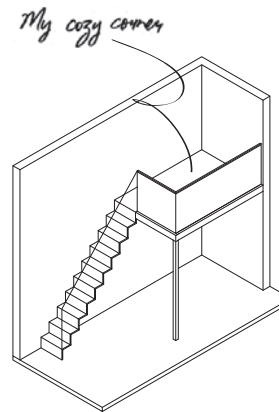

Isometric view of furniture deck
Clear ceiling height of 4.7m

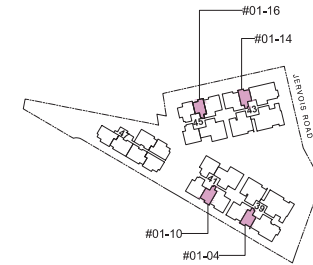

KEY PLAN
THIS KEY PLAN IS NOT TO SCALE

The above plan is subject to change as may be required or approved by the relevant authorities.
All floor areas are approximate and subject to final survey.

2-Bedroom
APARTMENT

 BUY CONDO 50



*"a home
where squirrels reside
in my neighborhood."*

2-Bedroom

Type B1

83 sqm / 893 sqft

Blk 41 #02-07 to #04-07
Blk 45 #02-20 to #04-20

(Mirrored)

Blk 41 #02-06 to #04-06
Blk 45 #02-19 to #04-19

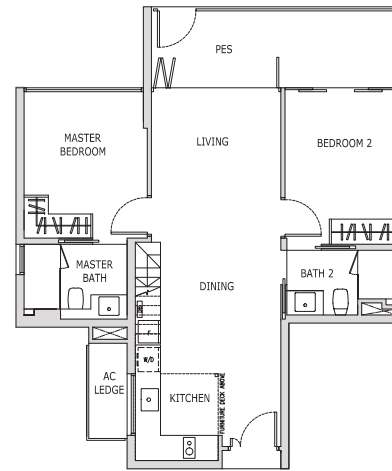
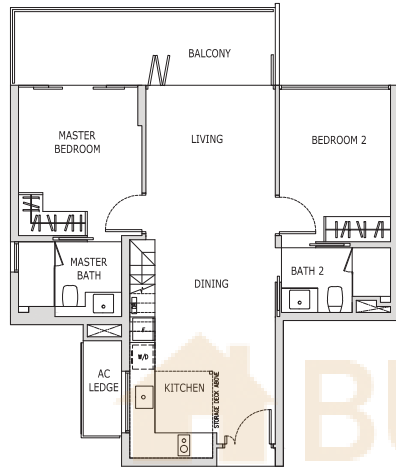

2-Bedroom

Type B1A (p)

82 sqm / 883 sqft

Blk 45 #01-20

2-Bedroom

Type B1 (p)

89 sqm / 958 sqft

Blk 41 #01-07

(Mirrored)

Blk 41 #01-06

Blk 45 #01-19

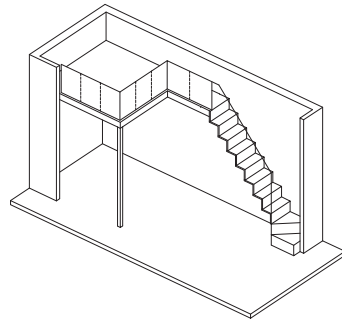
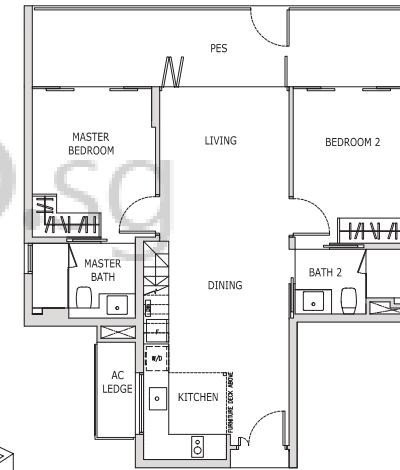

Isometric view of storage deck
Clear ceiling height of 3.3m

0 3 5M

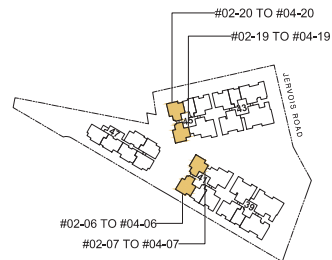

The above plan is subject to change as may be required or approved by the relevant authorities.
All floor areas are approximate and subject to final survey.

KEY PLAN
THIS KEY PLAN IS NOT TO SCALE

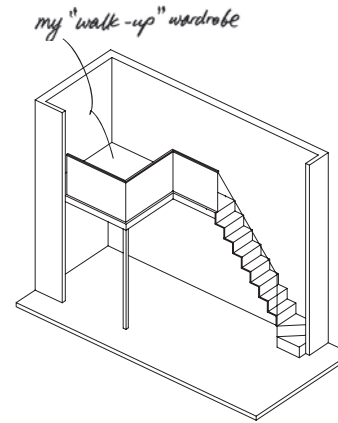

Isometric view of furniture deck
Clear ceiling height of 4.7m

0 3 5M

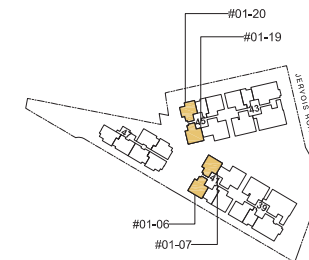

The above plan is subject to change as may be required or approved by the relevant authorities.
All floor areas are approximate and subject to final survey.

KEY PLAN
THIS KEY PLAN IS NOT TO SCALE

2-Bedroom

Type B2

93 sqm / 1,001 sqft

Blk 41 #02-09 to #04-09
Blk 43 #02-13 to #04-13

(Mirrored)

Blk 39 #02-05 to #04-05
Blk 45 #02-17 to #04-17

2-Bedroom

Type B2 (p)

96 sqm / 1,033 sqft

Blk 41 #01-09
Blk 43 #01-13

(Mirrored)

Blk 39 #01-05
Blk 45 #01-17

*My daily like-a-like with
Nature over a cuppa*

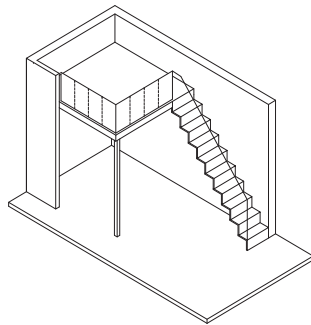
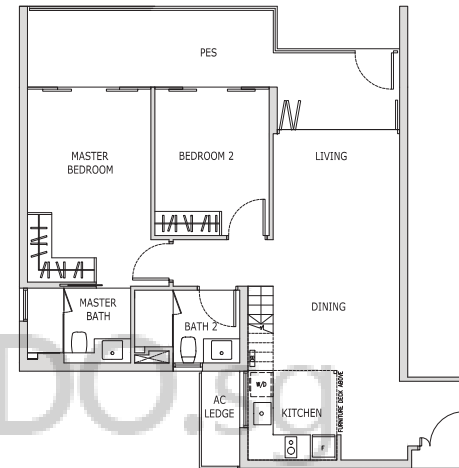
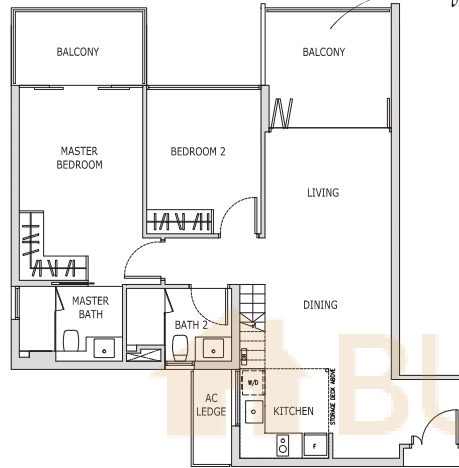

Isometric view of storage deck
Clear ceiling height of 3.3m

0 3 5M

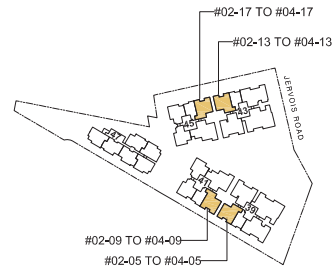

KEY PLAN
THIS KEY PLAN IS NOT TO SCALE

The above plan is subject to change as may be required or approved by the relevant authorities.
All floor areas are approximate and subject to final survey.

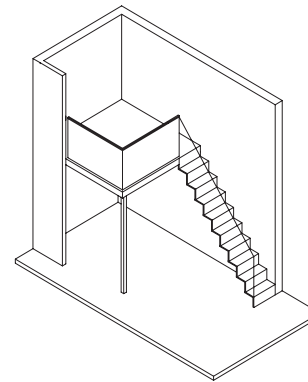

Isometric view of furniture deck
Clear ceiling height of 4.7m

0 3 5M

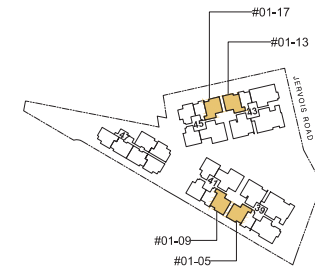

KEY PLAN
THIS KEY PLAN IS NOT TO SCALE

The above plan is subject to change as may be required or approved by the relevant authorities.
All floor areas are approximate and subject to final survey.

**2-Bedroom
+ Family Loft**

Type BL1A
143 sqm / 1,539 sqft
(Includes 20 sqm / 215 sqft
strata void)

Blk 47 #03-22
(Mirrored)
Blk 47 #03-23

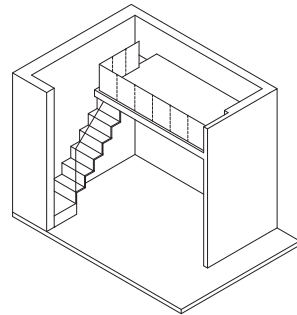
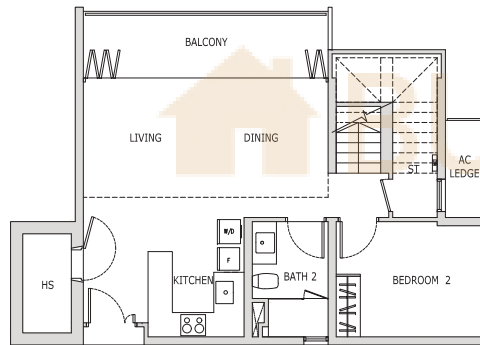
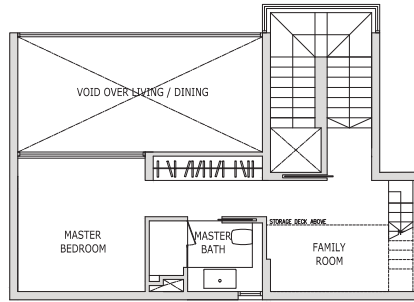

Isometric view of storage deck
Clear ceiling height of 3.2m

0 3 5M

The above plan is subject to change as may be required or approved by the relevant authorities.
All floor areas are approximate and subject to final survey.

KEY PLAN
THIS KEY PLAN IS NOT TO SCALE

**2-Bedroom
+ Family Loft**

Type BL1A (p)
145 sqm / 1,561 sqft
(Includes 20 sqm / 215 sqft
strata void)

Blk 47 #01-22
(Mirrored)
Blk 47 #01-23

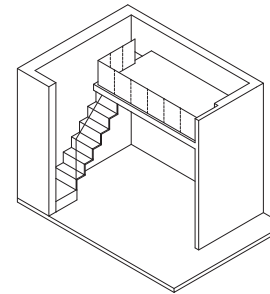
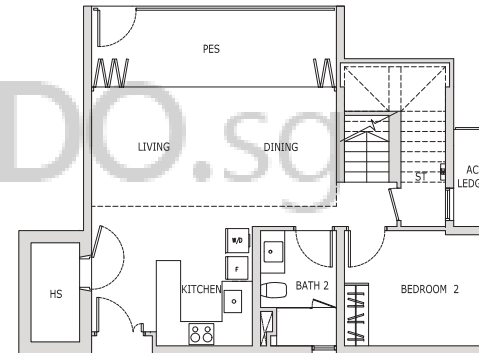
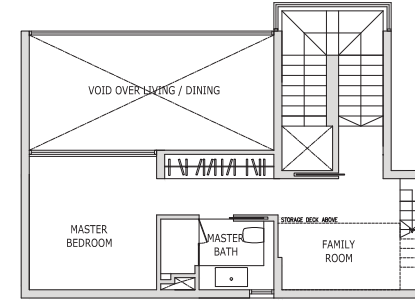

Isometric view of storage deck
Clear ceiling height of 3.2m

0 3 5M

The above plan is subject to change as may be required or approved by the relevant authorities.
All floor areas are approximate and subject to final survey.

KEY PLAN
THIS KEY PLAN IS NOT TO SCALE

**2-Bedroom
+ Family Loft**

Type BL1B
143 sqm / 1,539 sqft
(Includes 20 sqm / 215 sqft
strata void)
Blk 47 #03-26

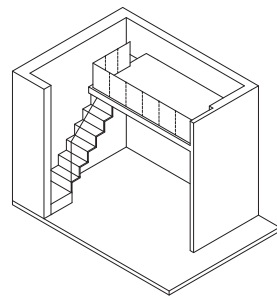
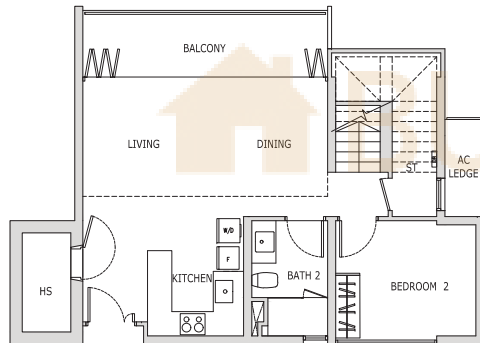
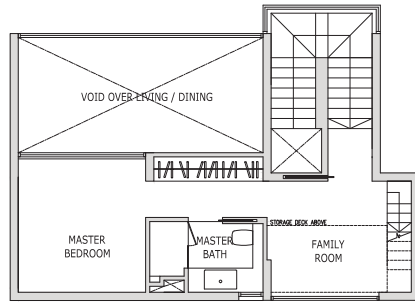

Isometric view of storage deck
Clear ceiling height of 3.2m

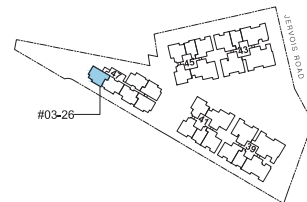

KEY PLAN
THIS KEY PLAN IS NOT TO SCALE

The above plan is subject to change as may be required or approved by the relevant authorities.
All floor areas are approximate and subject to final survey.

**2-Bedroom
+ Family Loft**

Type BL1 B (p)
145 sqm / 1,561 sqft
(Includes 20 sqm / 215 sqft
strata void)
Blk 47 #01-26

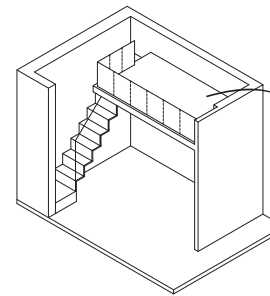
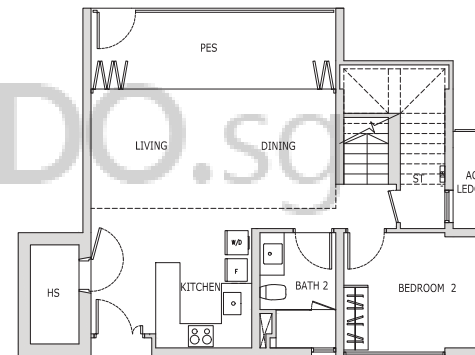
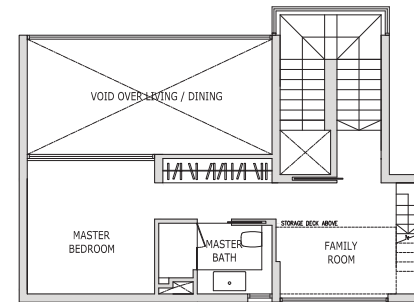

Isometric view of storage deck
Clear ceiling height of 3.2m

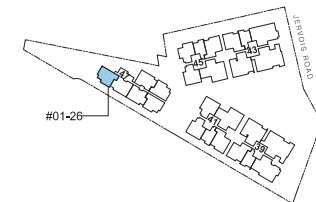

KEY PLAN
THIS KEY PLAN IS NOT TO SCALE

The above plan is subject to change as may be required or approved by the relevant authorities.
All floor areas are approximate and subject to final survey.

*A home for my dear Martin and
Neil Diamond records*

**2-Bedroom
+ Study Loft**

Type BL2A
147 sqm / 1,582 sqft
(Includes 30 sqm / 323 sqft
strata void)

Blk 47 #03-25
(Mirrored)
Blk 47 #03-24

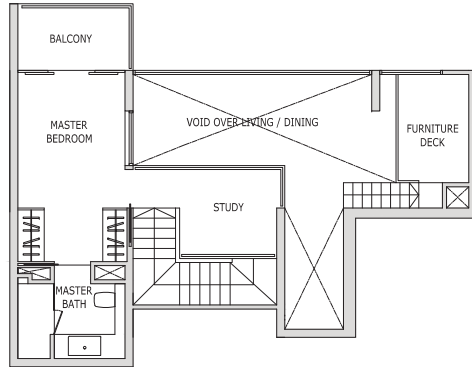

**2-Bedroom
+ Study Loft**

Type BL2A (p)
155 sqm / 1,668 sqft
(Includes 30 sqm / 323 sqft
strata void)

Blk 47 #01-25
(Mirrored)
Blk 47 #01-24

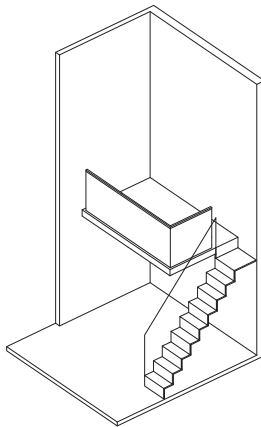
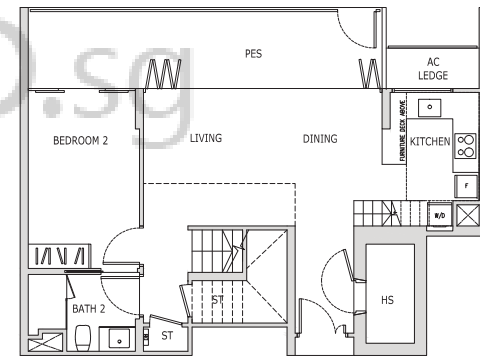
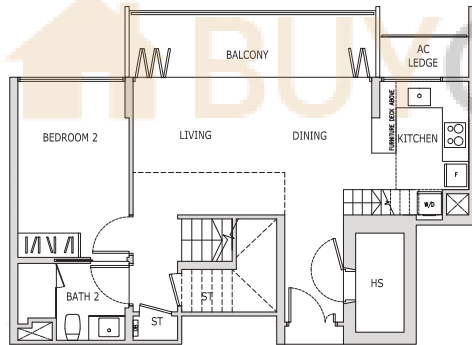
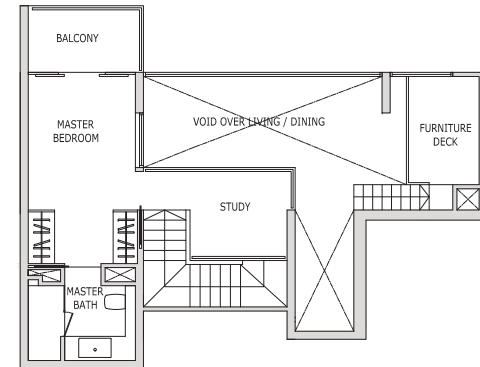

Isometric view of furniture deck
Clear ceiling height of 6.7m

0 3 5M

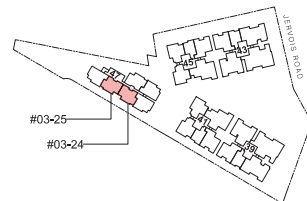

KEY PLAN
THIS KEY PLAN IS NOT TO SCALE

The above plan is subject to change as may be required or approved by the relevant authorities.
All floor areas are approximate and subject to final survey.

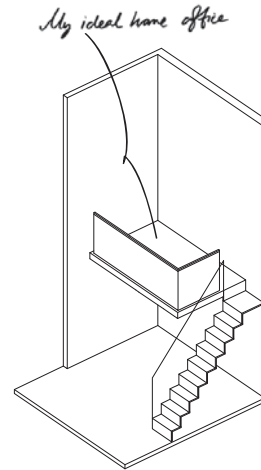

Isometric view of furniture deck
Clear ceiling height of 6.7m

0 3 5M

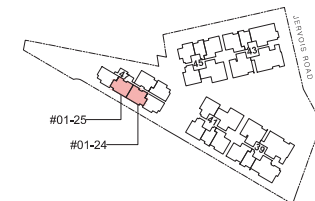

KEY PLAN
THIS KEY PLAN IS NOT TO SCALE

The above plan is subject to change as may be required or approved by the relevant authorities.
All floor areas are approximate and subject to final survey.

**2-Bedroom
+ Study Loft**

Type BL2B
147 sqm / 1,582 sqft
(Includes 30 sqm / 323 sqft
strata void)
Blk 47 #03-21

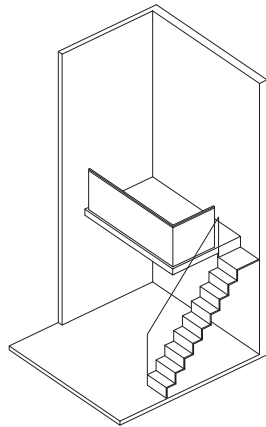
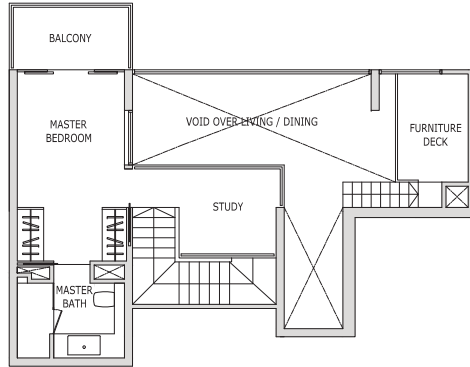

Isometric view of furniture deck
Clear ceiling height of 6.7m

0 3 5M

The above plan is subject to change as may be required or approved by the relevant authorities.
All floor areas are approximate and subject to final survey.

KEY PLAN
THIS KEY PLAN IS NOT TO SCALE

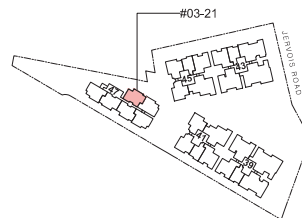

**2-Bedroom
+ Study Loft**

Type BL2B (p)
155 sqm / 1,668 sqft
(Includes 30 sqm / 323 sqft
strata void)
Blk 47 #01-21

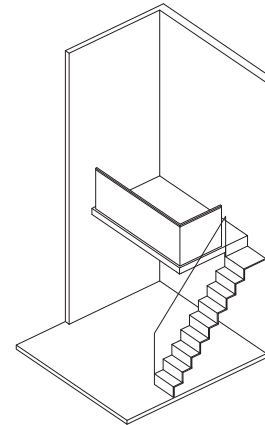
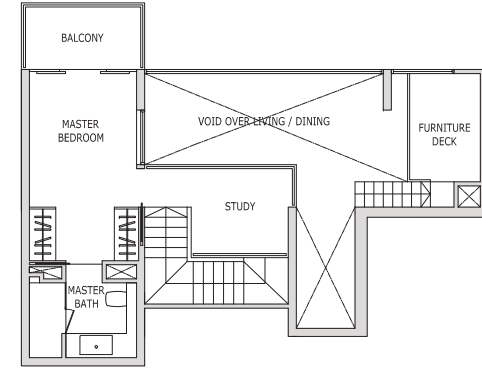

Isometric view of furniture deck
Clear ceiling height of 6.7m

0 3 5M

The above plan is subject to change as may be required or approved by the relevant authorities.
All floor areas are approximate and subject to final survey.

KEY PLAN
THIS KEY PLAN IS NOT TO SCALE

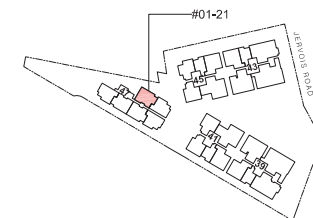

BUYER CONDO.SG

 BUYCONDOR



*"my oasis of green,
surrounded by
old world charm."*

3-Bedroom

Type C1
 131 sqm / 1,410 sqft
 Blk 39 #02-01 to #04-01
 (Mirrored)
 Blk 43 #02-12 to #04-12

3-Bedroom

Type C1 (p)
 139 sqm / 1,496 sqft
 Blk 39 #01-01
 (Mirrored)
 Blk 43 #01-12

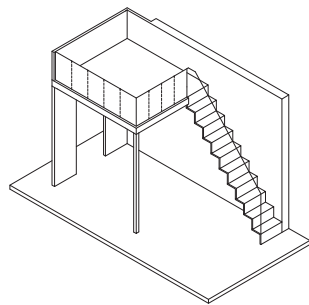
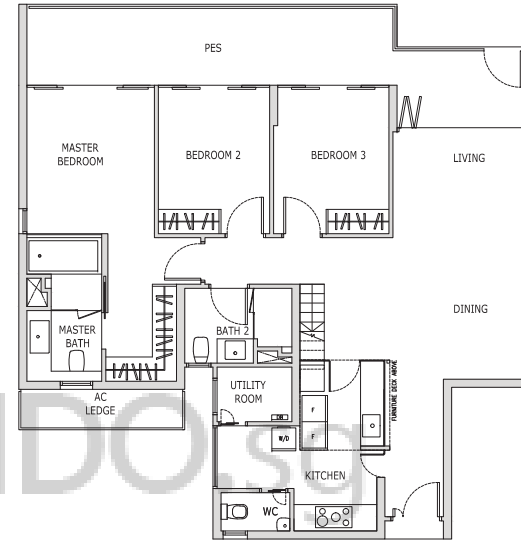
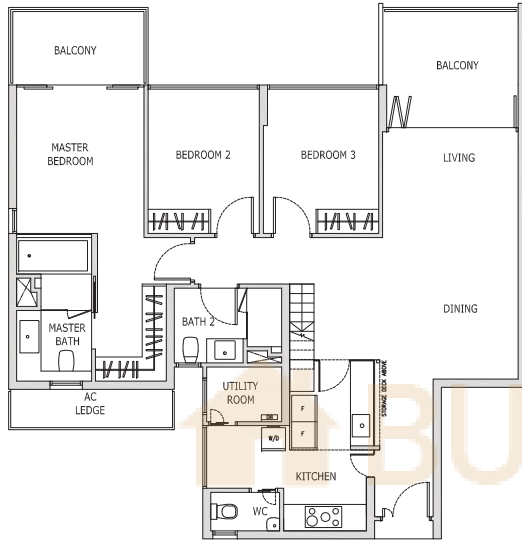

Isometric view of storage deck
 Clear ceiling height of 3.3m

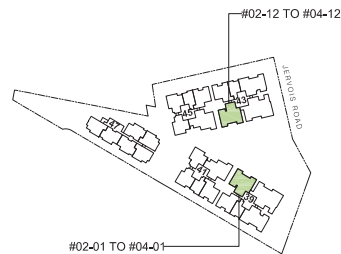

KEY PLAN
 THIS KEY PLAN IS NOT TO SCALE

The above plan is subject to change as may be required or approved by the relevant authorities.
 All floor areas are approximate and subject to final survey.

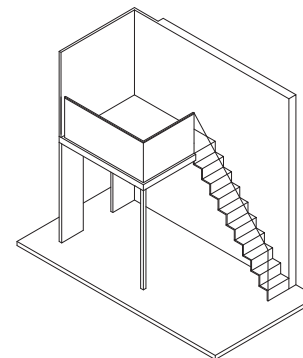

Isometric view of furniture deck
 Clear ceiling height of 4.7m

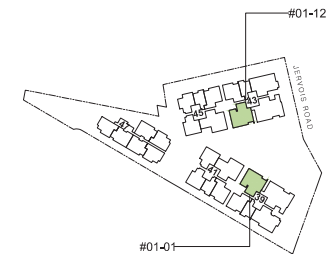

KEY PLAN
 THIS KEY PLAN IS NOT TO SCALE

The above plan is subject to change as may be required or approved by the relevant authorities.
 All floor areas are approximate and subject to final survey.

3-Bedroom

Type C2
 141 sqm / 1,518 sqft
 Blk 39 #02-03 to #04-03
 (Mirrored)
 Blk 43 #03-15 & #04-15

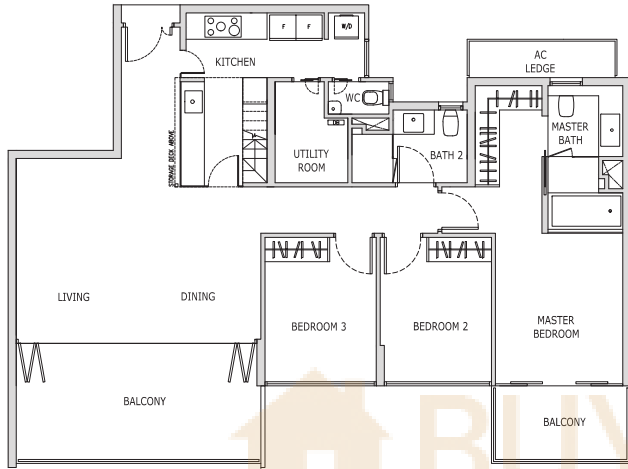

3-Bedroom

Type C2 (p)
 146 sqm / 1,572 sqft
 Blk 39 #01-03

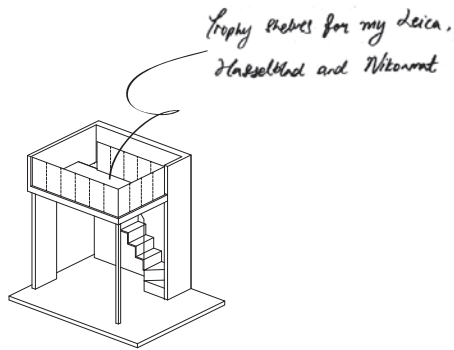
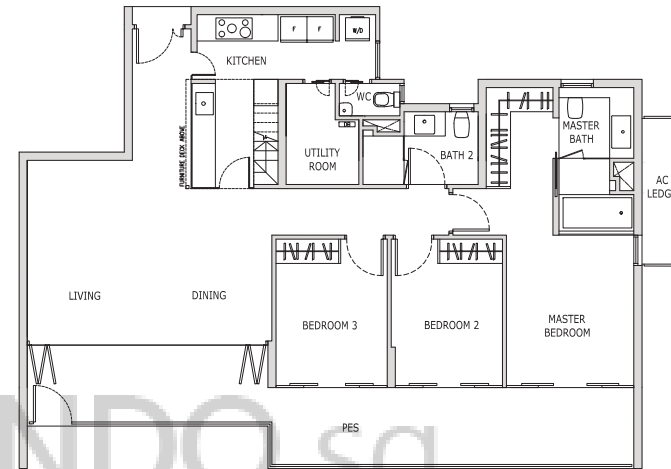

Isometric view of storage deck
 Clear ceiling height of 3.3m



The above plan is subject to change as may be required or approved by the relevant authorities.
 All floor areas are approximate and subject to final survey.



KEY PLAN
 THIS KEY PLAN IS NOT TO SCALE

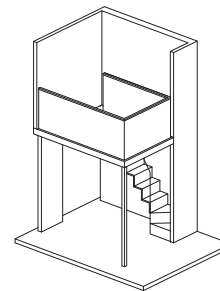

Isometric view of furniture deck
 Clear ceiling height of 4.7m



The above plan is subject to change as may be required or approved by the relevant authorities.
 All floor areas are approximate and subject to final survey.



KEY PLAN
 THIS KEY PLAN IS NOT TO SCALE

3-Bedroom

Type C3
 129 sqm / 1,389 sqft
 Blk 41 #02-08 to #04-08
 (Mirrored)
 Blk 45 #02-18 to #04-18

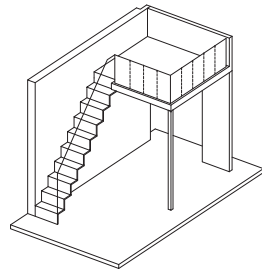
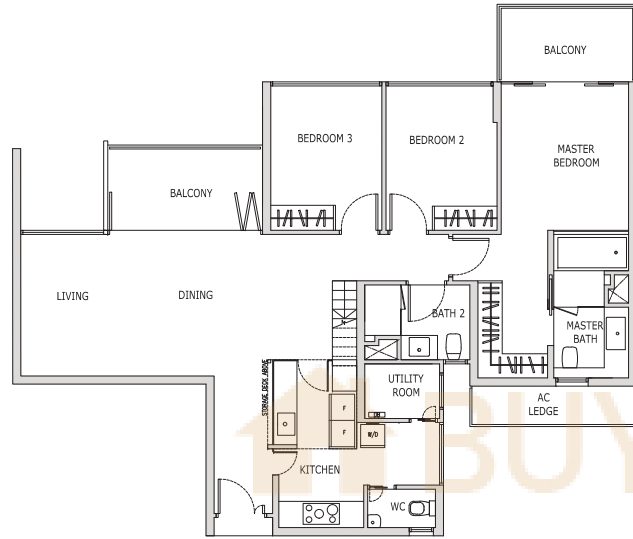

Isometric view of storage deck
 Clear ceiling height of 3.3m

0 3 5M



KEY PLAN
 THIS KEY PLAN IS NOT TO SCALE

The above plan is subject to change as may be required or approved by the relevant authorities.
 All floor areas are approximate and subject to final survey.

3-Bedroom

Type C3 (p)
 145 sqm / 1,561 sqft
 Blk 41 #01-08
 (Mirrored)
 Blk 45 #01-18

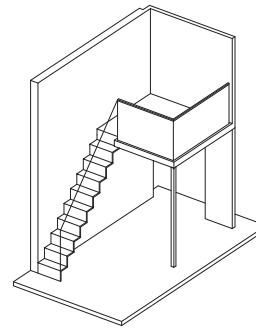
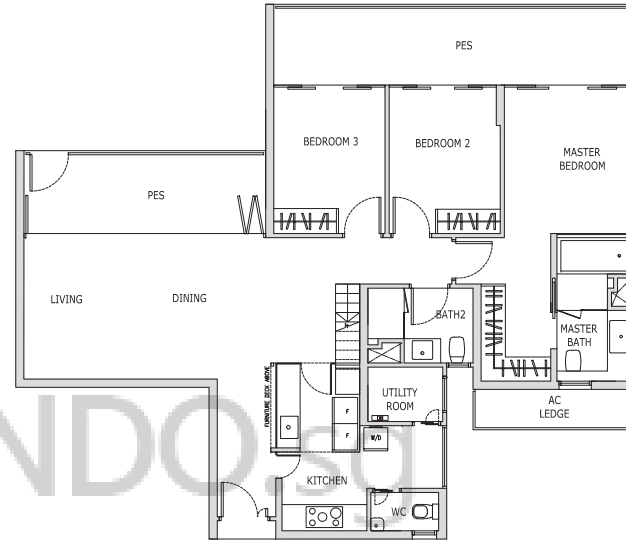

Isometric view of furniture deck
 Clear ceiling height of 4.7m

0 3 5M

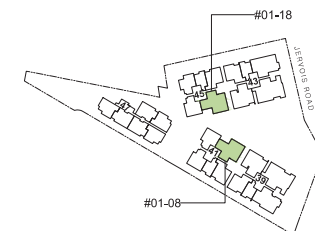

KEY PLAN
 THIS KEY PLAN IS NOT TO SCALE

The above plan is subject to change as may be required or approved by the relevant authorities.
 All floor areas are approximate and subject to final survey.

 BUY CONDO



*"It's just me and my trusty swing
in my secret garden."*

4-Bedroom

Type D
 177 sqm / 1,905 sqft
 Blk 39 #02-02 to #04-02
 (Mirrored)
 Blk 43 #02-11 to #04-11

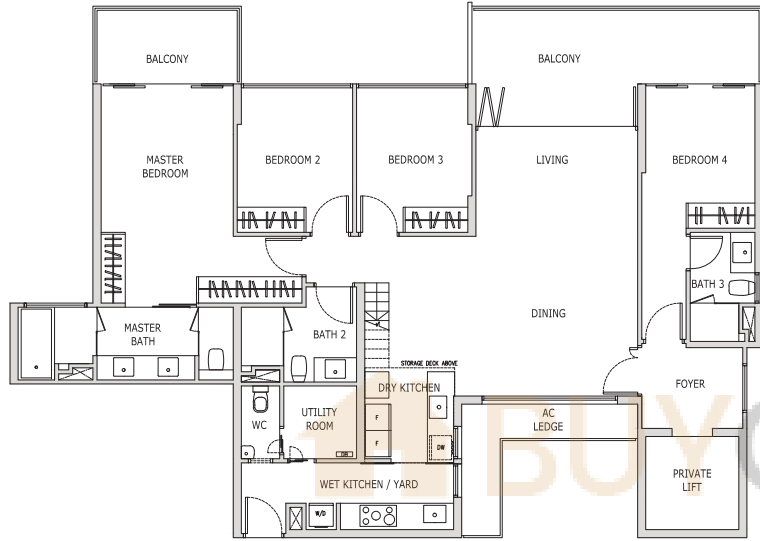

4-Bedroom

Type D (p)
 184 sqm / 1,981 sqft
 Blk 39 #01-02
 (Mirrored)
 Blk 43 #01-11

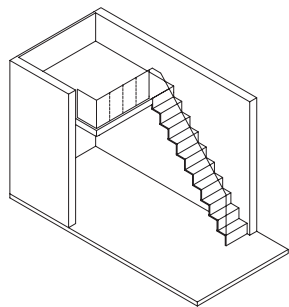
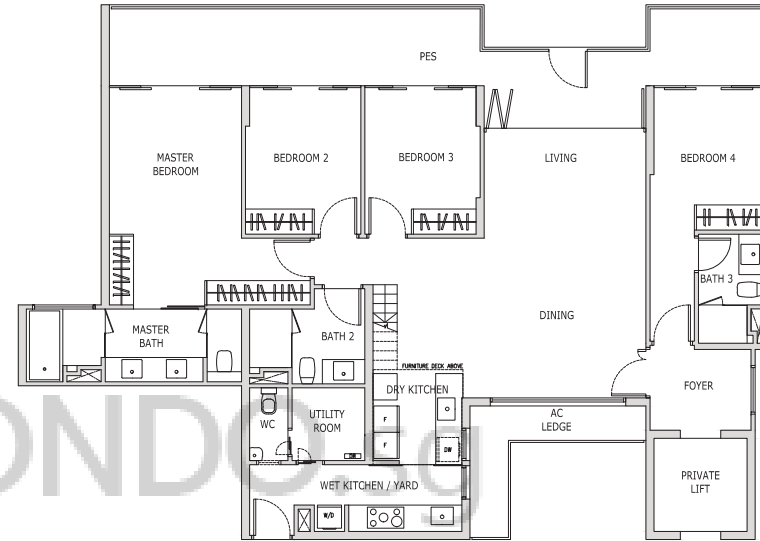

Isometric view of storage deck
 Clear ceiling height of 3.3m



KEY PLAN
 THIS KEY PLAN IS NOT TO SCALE

The above plan is subject to change as may be required or approved by the relevant authorities.
 All floor areas are approximate and subject to final survey.

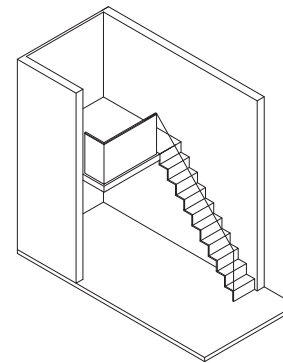

Isometric view of furniture deck
 Clear ceiling height of 4.7m



KEY PLAN
 THIS KEY PLAN IS NOT TO SCALE

The above plan is subject to change as may be required or approved by the relevant authorities.
 All floor areas are approximate and subject to final survey.

 BUYCONDO.SG



*“Live an invitation
that even nature
can't resist.”*

Penthouse

Type PH1
 244 sqm / 2,626 sqft
 Blk 39 #05-01
 (Mirrored)
 Blk 43 #05-12

The best party venue under the stars

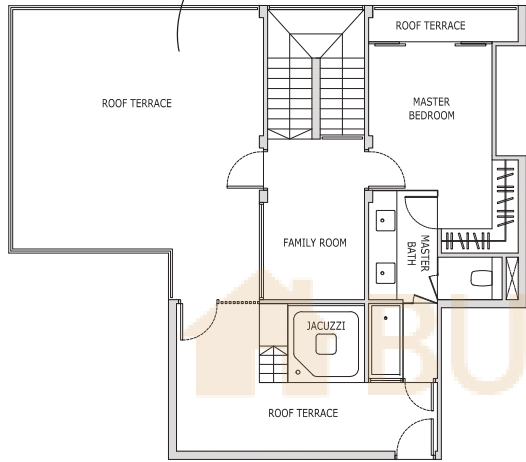

Upper Level

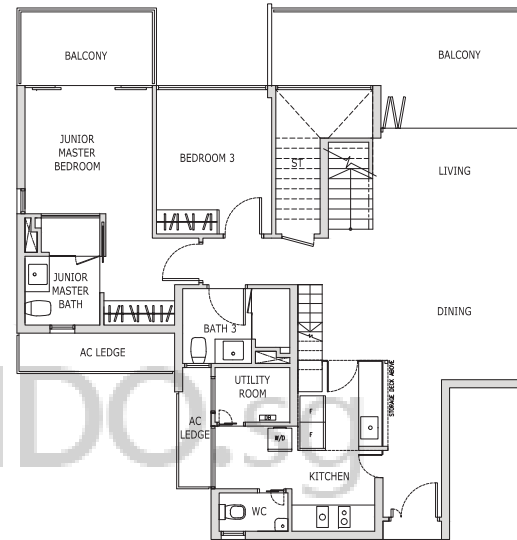

Lower Level

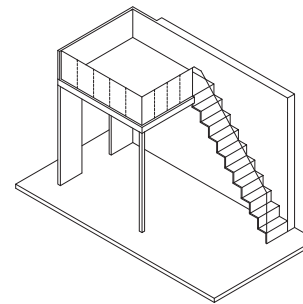

Isometric view of storage deck
 Clear ceiling height of 3.3m

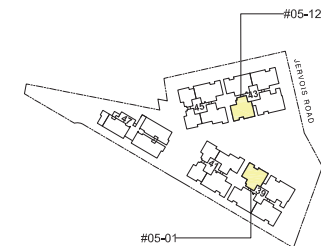

KEY PLAN
 THIS KEY PLAN IS NOT TO SCALE



The above plan is subject to change as may be required or approved by the relevant authorities.
 All floor areas are approximate and subject to final survey.

Penthouse

Type PH2
 248 sqm / 2,669 sqft
 Blk 43 #05-15
 (Mirrored)
 Blk 39 #05-03

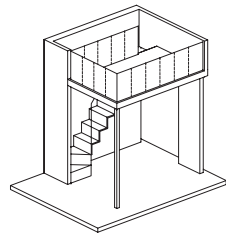
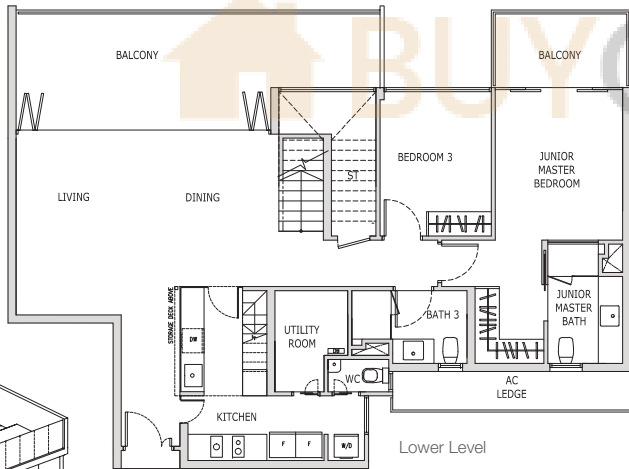
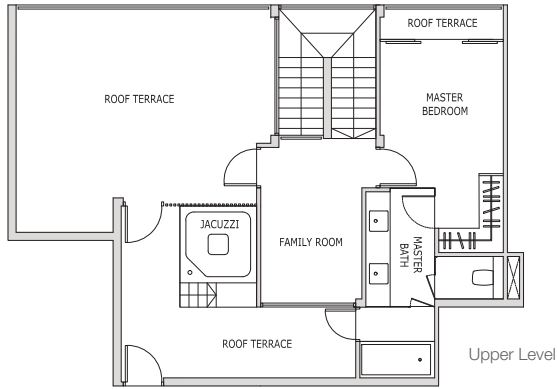

Isometric view of storage deck
 Clear ceiling height of 3.3m

0 3 5M



KEY PLAN
 THIS KEY PLAN IS NOT TO SCALE

The above plan is subject to change as may be required or approved by the relevant authorities.
 All floor areas are approximate and subject to final survey.

Penthouse

Type PH3
 137 sqm / 1,475 sqft
 (Includes 6 sqm / 65 sqft
 strata void)
 Blk 41 #05-07
 Blk 45 #05-20
 (Mirrored)
 Blk 41 #05-06
 Blk 45 #05-19

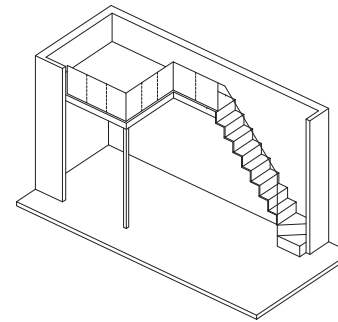
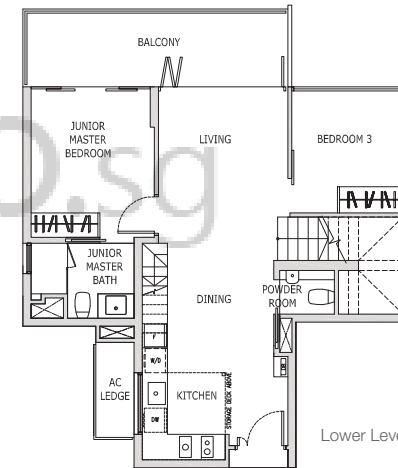
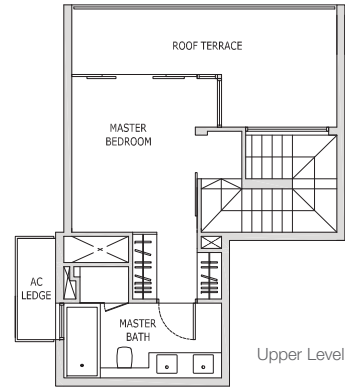

Isometric view of storage deck
 Clear ceiling height of 3.3m

0 3 5M

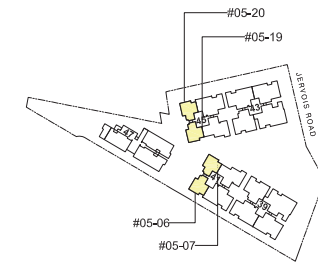

KEY PLAN
 THIS KEY PLAN IS NOT TO SCALE

The above plan is subject to change as may be required or approved by the relevant authorities.
 All floor areas are approximate and subject to final survey.

Penthouse

Type PH4
 279 sqm / 3,003 sqft
 Blk 39 #05-02
 (Mirrored)
 Blk 43 #05-11

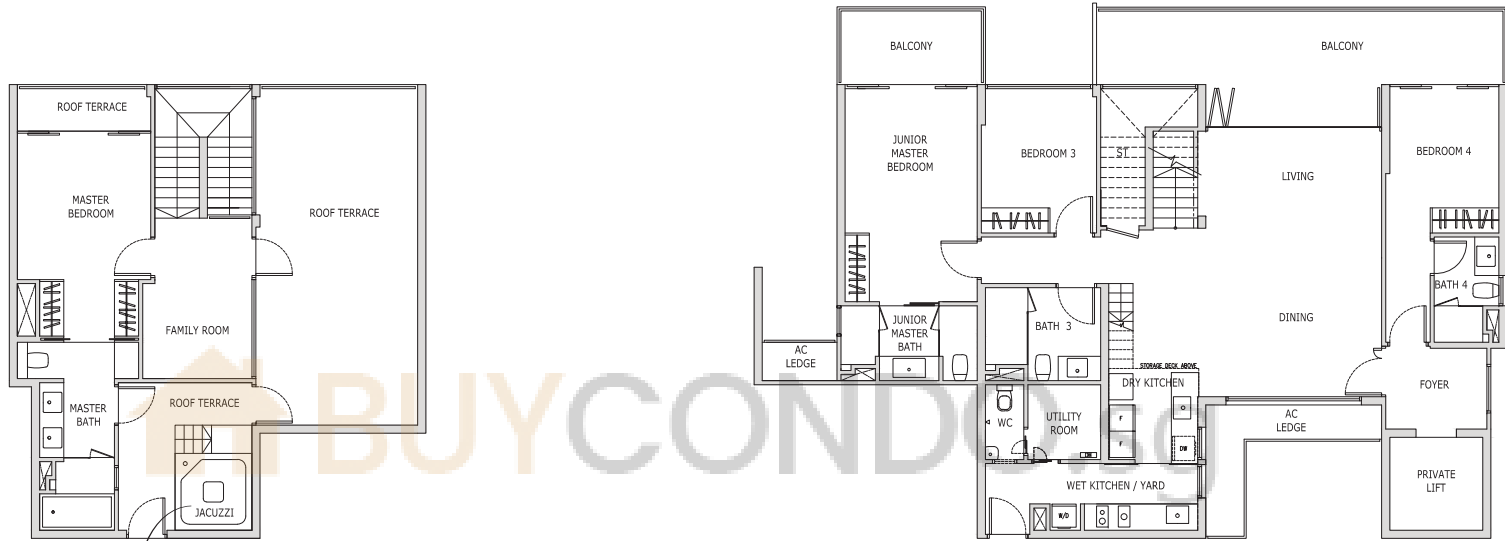

Upper Level

Lower Level

*Evening indulgence - sipping bubbly
 in my bubble bath*

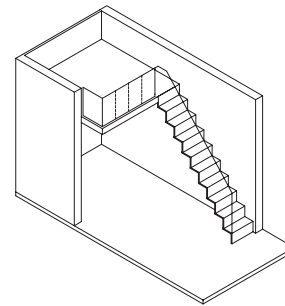

Isometric view of storage deck
 Clear ceiling height of 3.3m

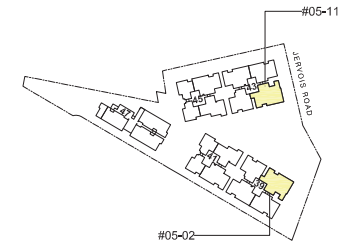

KEY PLAN
 THIS KEY PLAN IS NOT TO SCALE



The above plan is subject to change as may be required or approved by the relevant authorities.
 All floor areas are approximate and subject to final survey.

Penthouse

Type PH5
 264 sqm / 2,842 sqft
 Blk 41 #05-09
 Blk 43 #05-14
 (Mirrored)
 Blk 39 #05-04
 Blk 45 #05-16

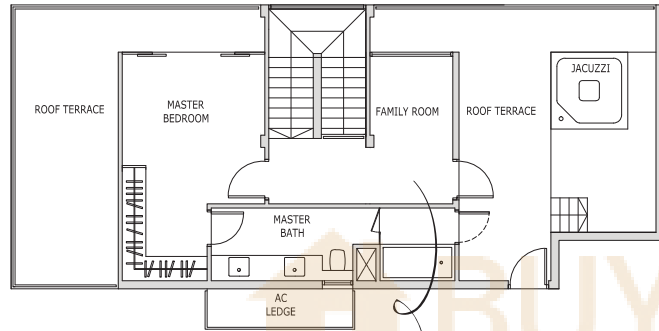

Pure audio pleasure with my Martin Cottone

Upper Level

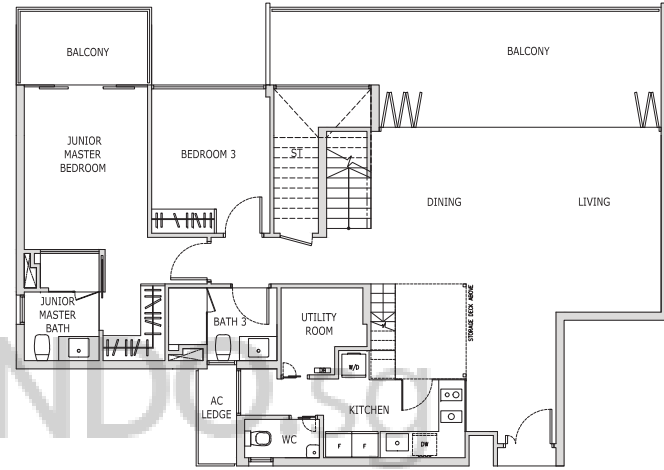

Lower Level

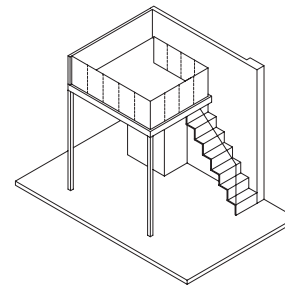

Isometric view of storage deck
 Clear ceiling height of 3.3m



The above plan is subject to change as may be required or approved by the relevant authorities.
 All floor areas are approximate and subject to final survey.

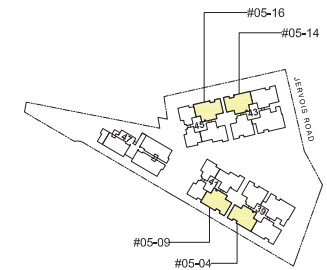

KEY PLAN
 THIS KEY PLAN IS NOT TO SCALE

Penthouse

Type PH6
 220 sqm / 2,368 sqft
 Blk 41 #05-08
 (Mirrored)
 Blk 45 #05-18

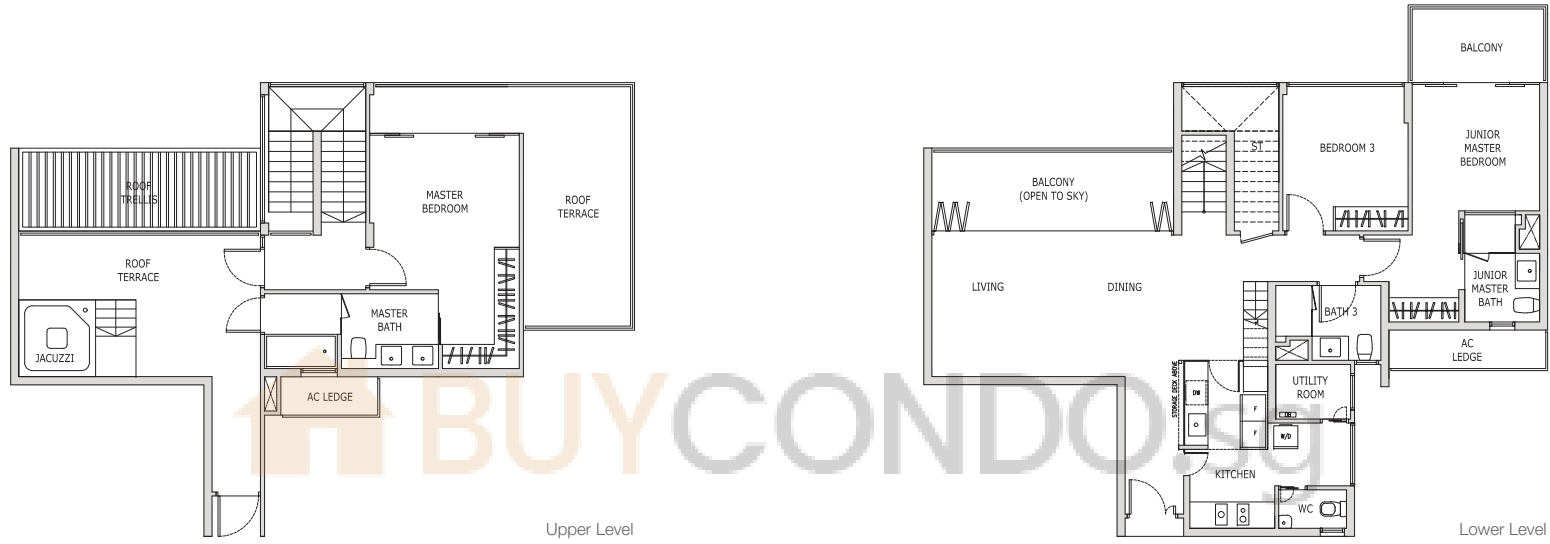

Upper Level

Lower Level

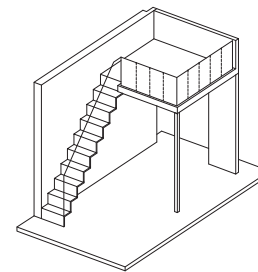

Isometric view of storage deck
 Clear ceiling height of 3.3m

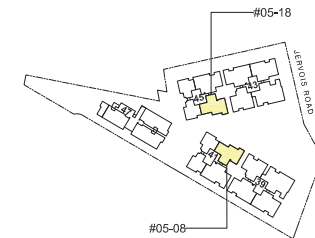

KEY PLAN
 THIS KEY PLAN IS NOT TO SCALE



The above plan is subject to change as may be required or approved by the relevant authorities.
 All floor areas are approximate and subject to final survey.

Penthouse

Type PH7A
 216 sqm / 2,325 sqft
 Blk 47 #05-21
 (Mirrored)
 Blk 47 #05-23

Penthouse

Type PH7B
 187 sqm / 2,013 sqft
 Blk 47 #05-25

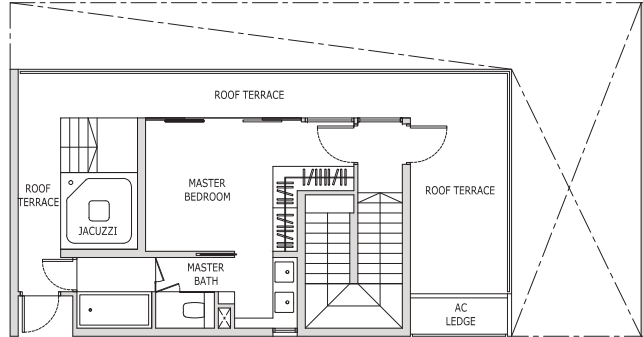

Upper Level

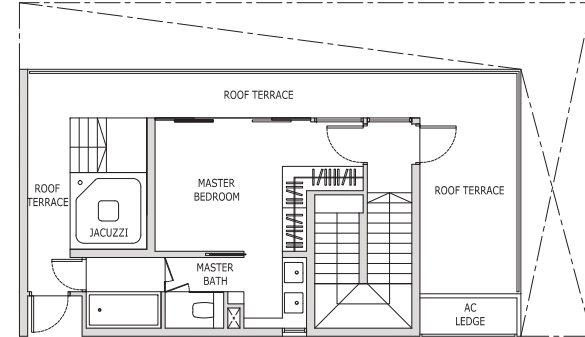

Upper Level

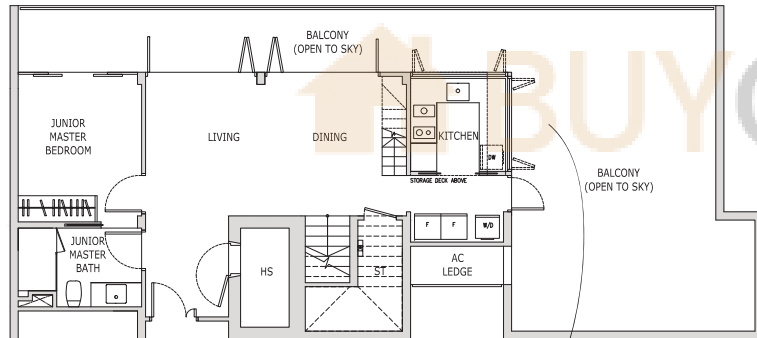

Lower Level

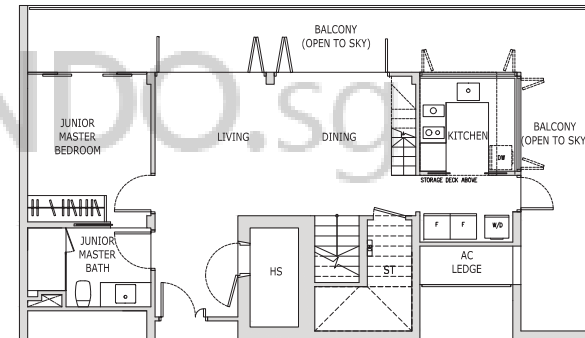

Lower Level

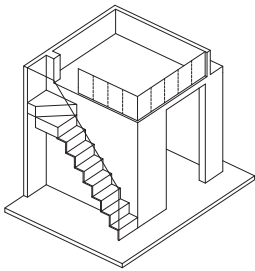

Isometric view of storage deck
 Clear ceiling height of 3.2m



*The perfect breakfast nook
 on a lazy Sunday*

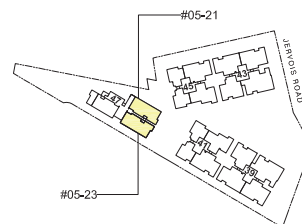

KEY PLAN
 THIS KEY PLAN IS NOT TO SCALE

The above plan is subject to change as may be required or approved by the relevant authorities.
 All floor areas are approximate and subject to final survey.

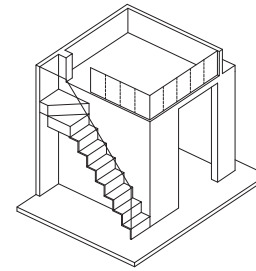

Isometric view of storage deck
 Clear ceiling height of 3.2m

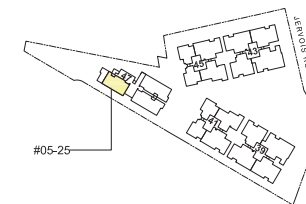

KEY PLAN
 THIS KEY PLAN IS NOT TO SCALE

The above plan is subject to change as may be required or approved by the relevant authorities.
 All floor areas are approximate and subject to final survey.