

2-BEDROOM

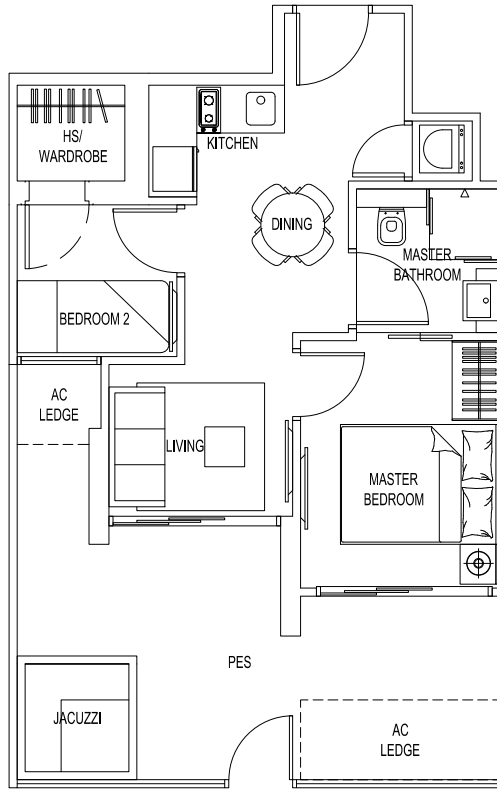

A1-G

AREA: 56.0 sqm

UNIT: #07-07

7TH STOREY

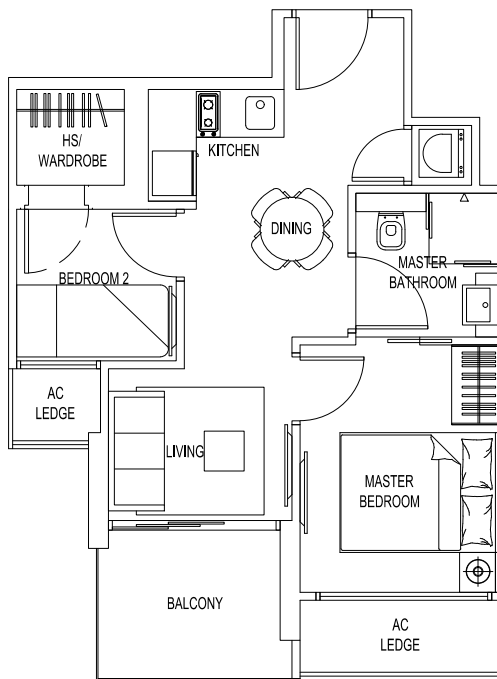
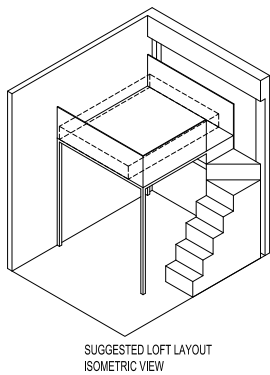
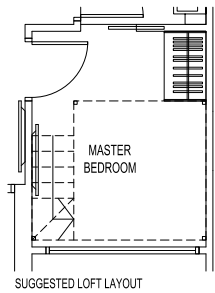

A1

AREA: 45.0 sqm

UNIT: #08-07, #09-07,
#10-07, #11-07, #12-07,
#13-07, #14-07, #15-07,
#16-07, #17-07, #18-07,
#19-07, #20-07, #21-07,
#22-07, #23-07, #24-07,
#25-07, #26-07

8TH TO 26TH STOREY

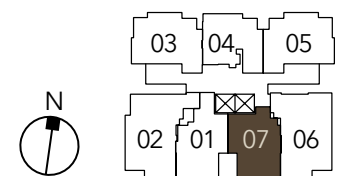

All floor area indicated are inclusive of aircon ledge, balcony, open balcony, roof terrace and private enclosed space (PES), where applicable. Areas are estimates only and subject to final survey. All floor plans are subject to changes as may be required or approved by the relevant authorities. Furniture shown are indicative only and are not provided. Please refer to the floor plans in the Sales & Purchase Agreement for details.



2-BEDROOM

A2-G

AREA: 56.0 sqm

UNIT: #07-01

7TH STOREY

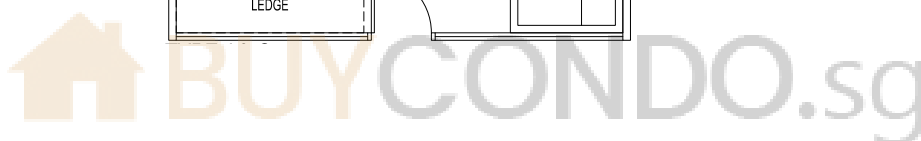
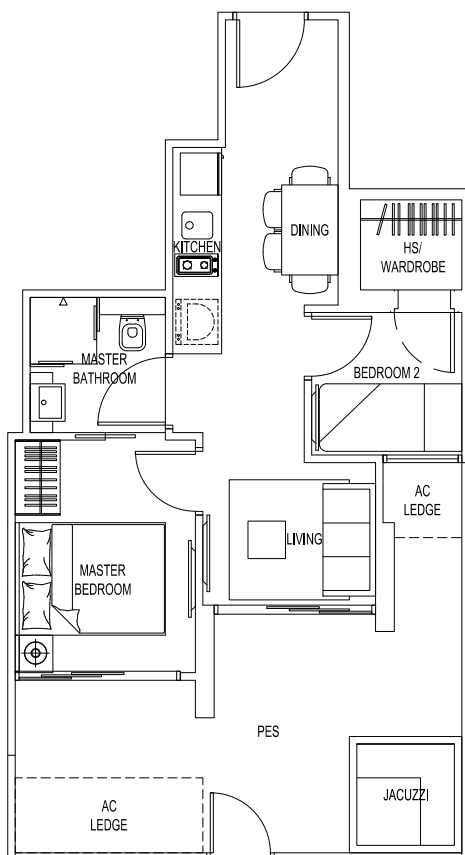

A2

AREA: 45.0 sqm

UNIT: #08-01, #09-01,
#10-01, #11-01, #12-01,
#13-01, #14-01, #15-01,
#16-01, #17-01, #18-01,
#19-01, #20-01, #21-01,
#22-01, #23-01, #24-01,
#25-01, #26-01

8TH TO 26TH STOREY

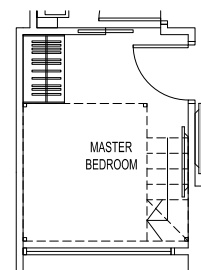
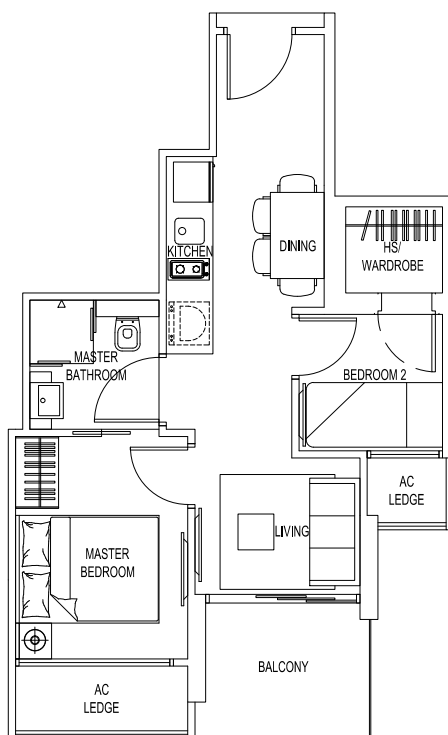

SUGGESTED LOFT LAYOUT

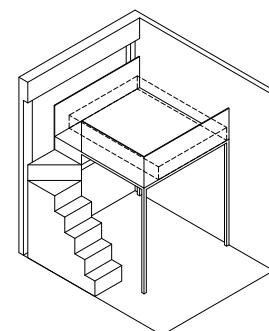

SUGGESTED LOFT LAYOUT ISOMETRIC VIEW

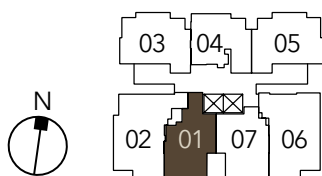

All floor area indicated are inclusive of aircon ledge, balcony, open balcony, roof terrace and private enclosed space (PES), where applicable. Areas are estimates only and subject to final survey. All floor plans are subject to changes as may be required or approved by the relevant authorities. Furniture shown are indicative only and are not provided. Please refer to the floor plans in the Sales & Purchase Agreement for details.

2-BEDROOM

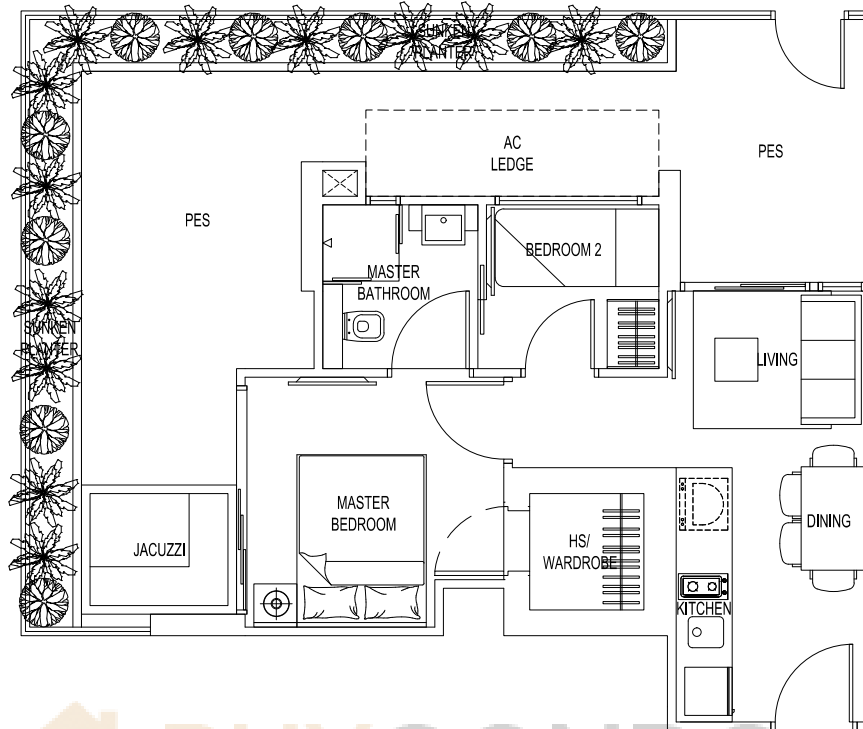

A3-G

AREA: 73.0 sqm

UNIT: #07-03

7TH STOREY

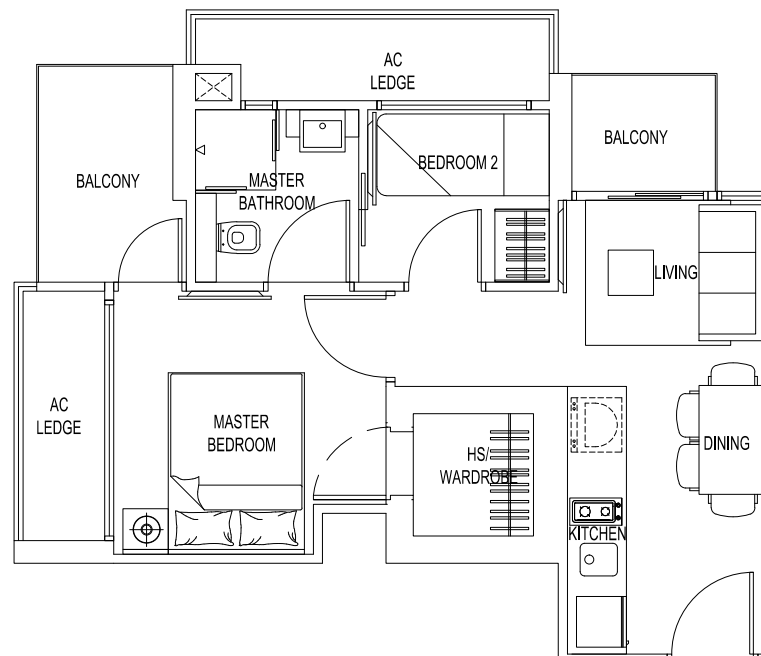
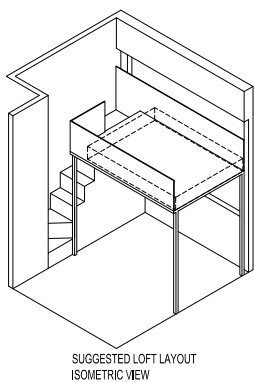
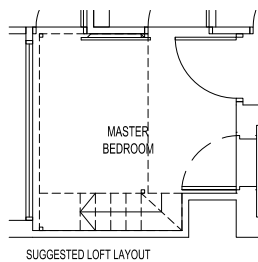

A3

AREA: 49.0 sqm

UNIT: #08-03, #09-03, #10-03, #11-03, #12-03, #13-03, #14-03, #15-03, #16-03, #17-03, #18-03, #19-03, #20-03, #21-03, #22-03, #23-03, #24-03, #25-03, #26-03, #27-03
8TH TO 27TH STOREY

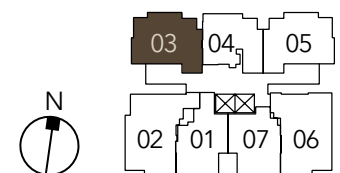

All floor area indicated are inclusive of aircon ledge, balcony, open balcony, roof terrace and private enclosed space (PES), where applicable. Areas are estimates only and subject to final survey. All floor plans are subject to changes as may be required or approved by the relevant authorities. Furniture shown are indicative only and are not provided. Please refer to the floor plans in the Sales & Purchase Agreement for details.



2-BEDROOM

A4-G

AREA: 53.0 sqm

UNIT: #07-04

7TH STOREY

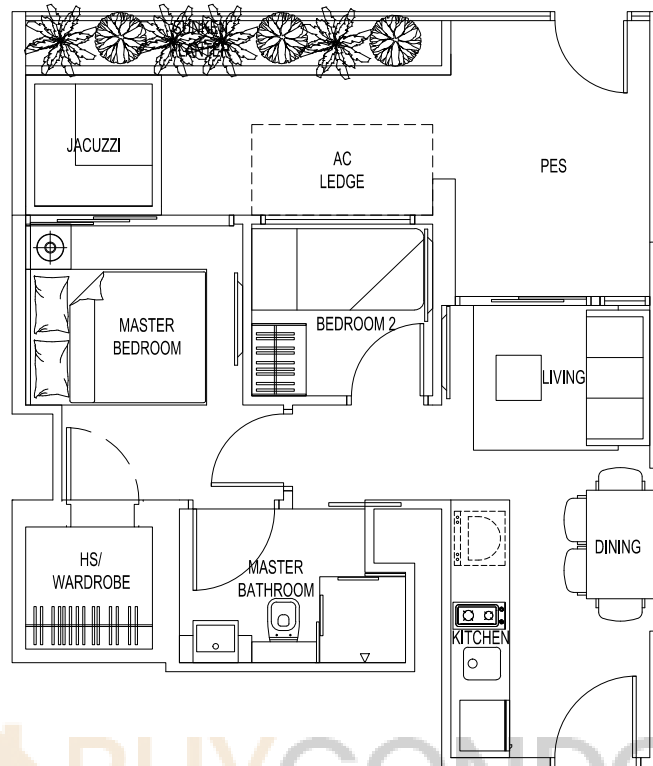

A4

AREA: 42.0 sqm

UNIT: #08-04, #09-04,
#10-04, #11-04, #12-04,
#13-04, #14-04, #15-04,
#16-04, #17-04, #18-04,
#19-04, #20-04, #21-04,
#22-04, #23-04, #24-04,
#25-04, #26-04, #27-04
8TH TO 27TH STOREY

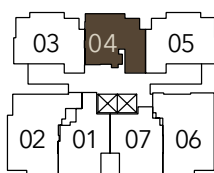
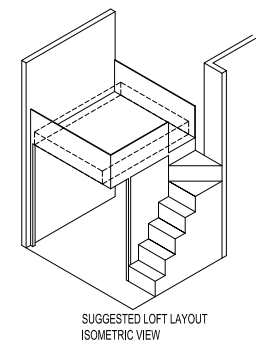
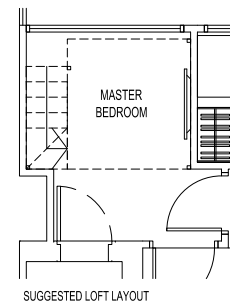
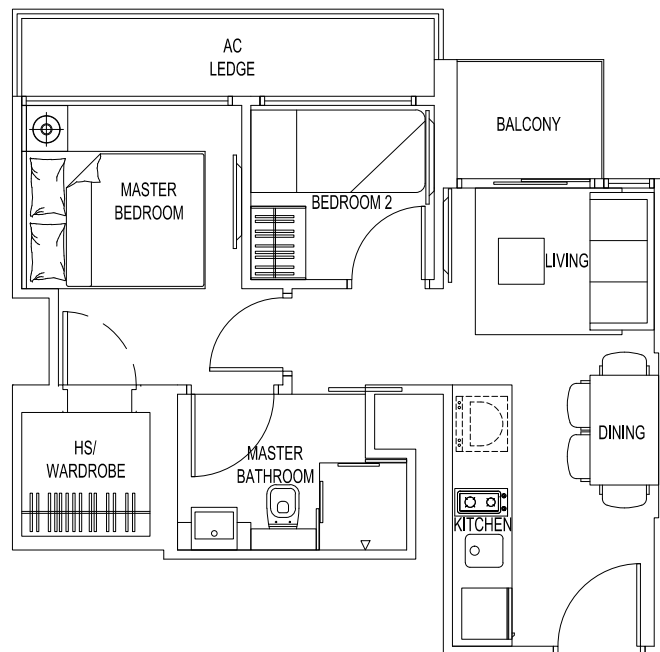

All floor area indicated are inclusive of aircon ledge, balcony, open balcony, roof terrace and private enclosed space (PES), where applicable. Areas are estimates only and subject to final survey. All floor plans are subject to changes as may be required or approved by the relevant authorities. Furniture shown are indicative only and are not provided. Please refer to the floor plans in the Sales & Purchase Agreement for details.

2-BEDROOM

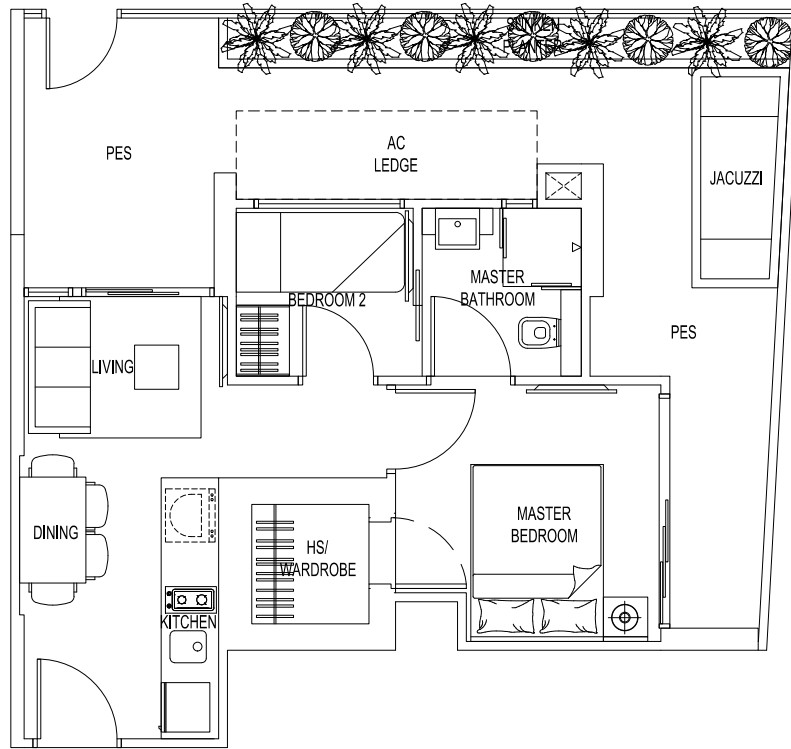

A5-G

AREA: 64.0 sqm

UNIT: #07-05

7TH STOREY

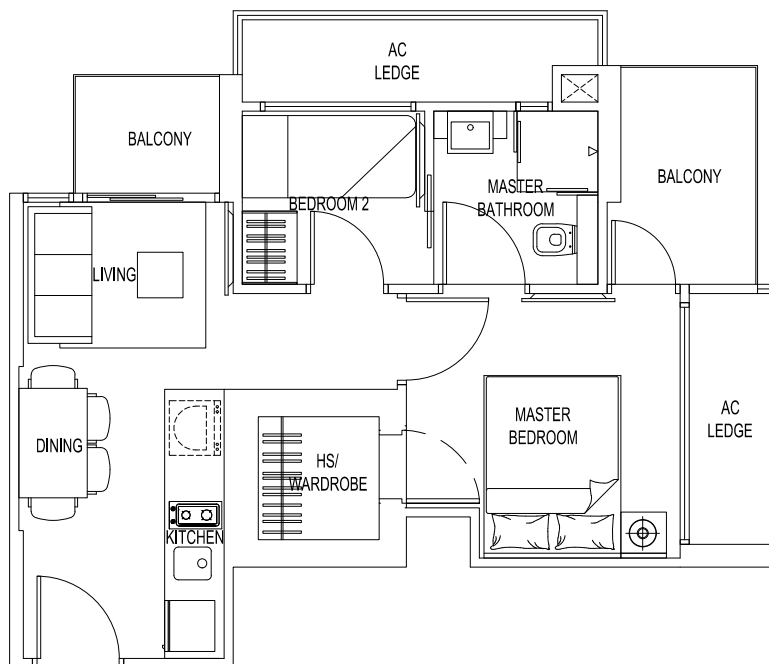

A5

AREA: 49.0 sqm

UNIT: #08-05, #09-05, #10-05, #11-05, #12-05, #13-05, #14-05, #15-05, #16-05, #17-05, #18-05, #19-05, #20-05, #21-05, #22-05, #23-05, #24-05, #25-05, #26-05, #27-05
8TH TO 27TH STOREY

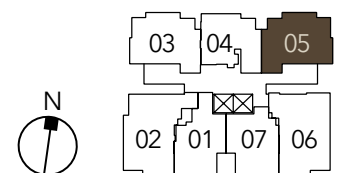
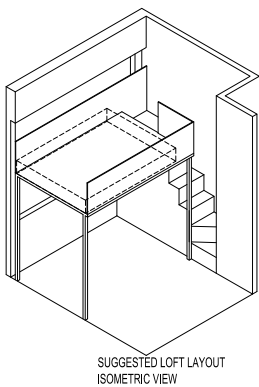
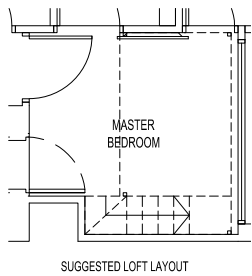

All floor area indicated are inclusive of aircon ledge, balcony, open balcony, roof terrace and private enclosed space (PES), where applicable. Areas are estimates only and subject to final survey. All floor plans are subject to changes as may be required or approved by the relevant authorities. Furniture shown are indicative only and are not provided. Please refer to the floor plans in the Sales & Purchase Agreement for details.



2-BEDROOM + 1 STUDY

B1-G

AREA: 83.0 sqm

UNIT: #07-06

7TH STOREY

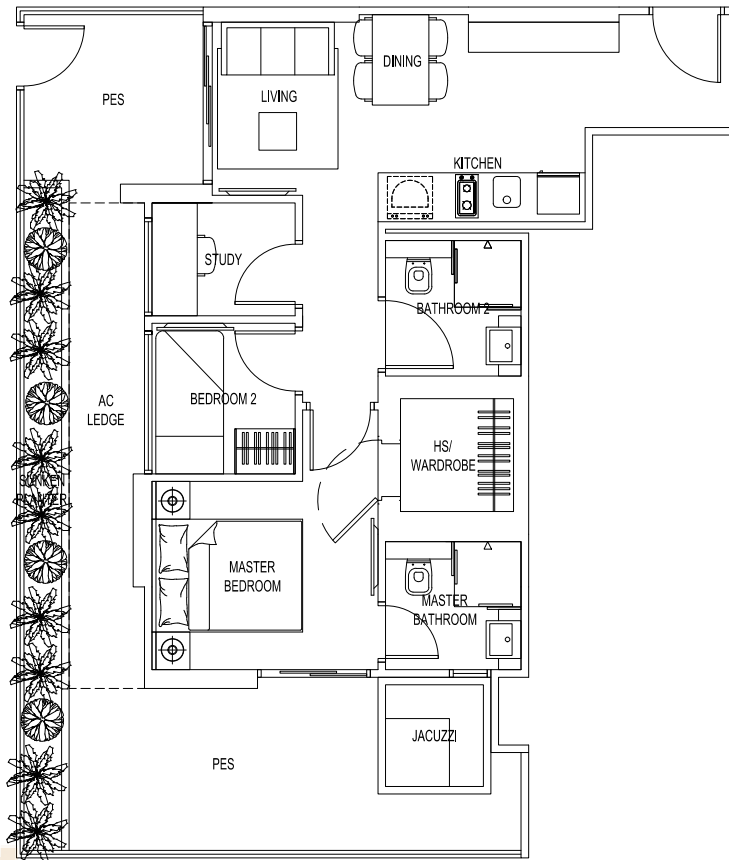

B1

AREA: 61.0 sqm

UNIT: #08-06, #09-06,
#10-06, #11-06, #12-06,
#13-06, #14-06, #15-06,
#16-06, #17-06, #18-06,
#19-06, #20-06, #21-06,
#22-06, #23-06, #24-06,
#25-06, #26-06, #27-06
8TH TO 27TH STOREY

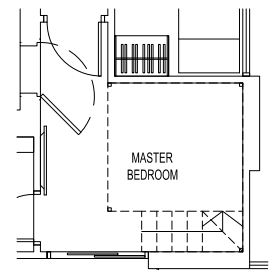
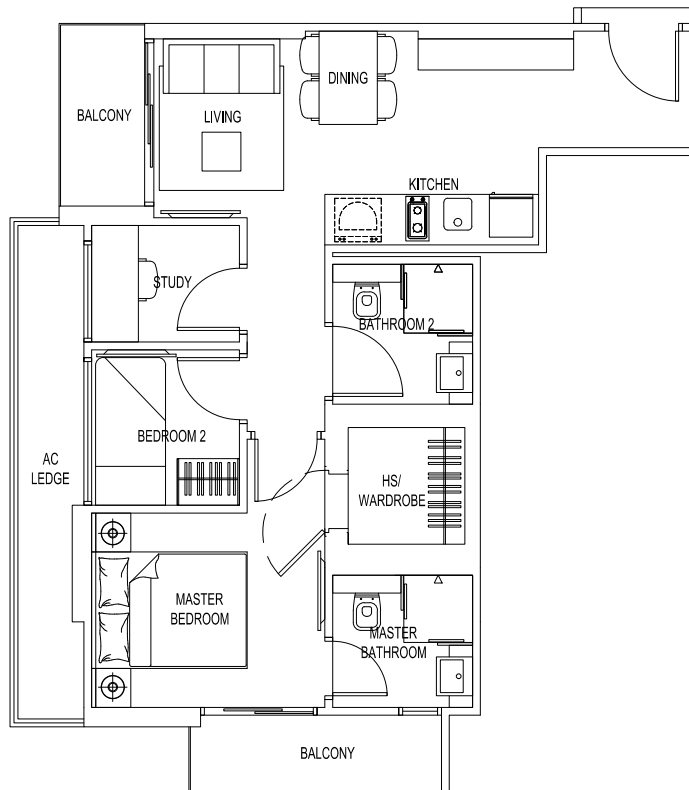

SUGGESTED LOFT LAYOUT

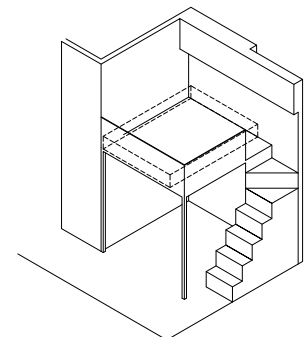

SUGGESTED LOFT LAYOUT ISOMETRIC VIEW

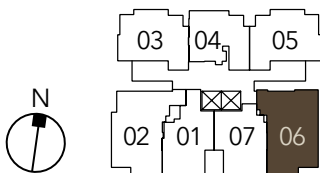

All floor area indicated are inclusive of aircon ledge, balcony, open balcony, roof terrace and private enclosed space (PES), where applicable. Areas are estimates only and subject to final survey. All floor plans are subject to changes as may be required or approved by the relevant authorities. Furniture shown are indicative only and are not provided. Please refer to the floor plans in the Sales & Purchase Agreement for details.

2 -BEDROOM + 1 STUDY

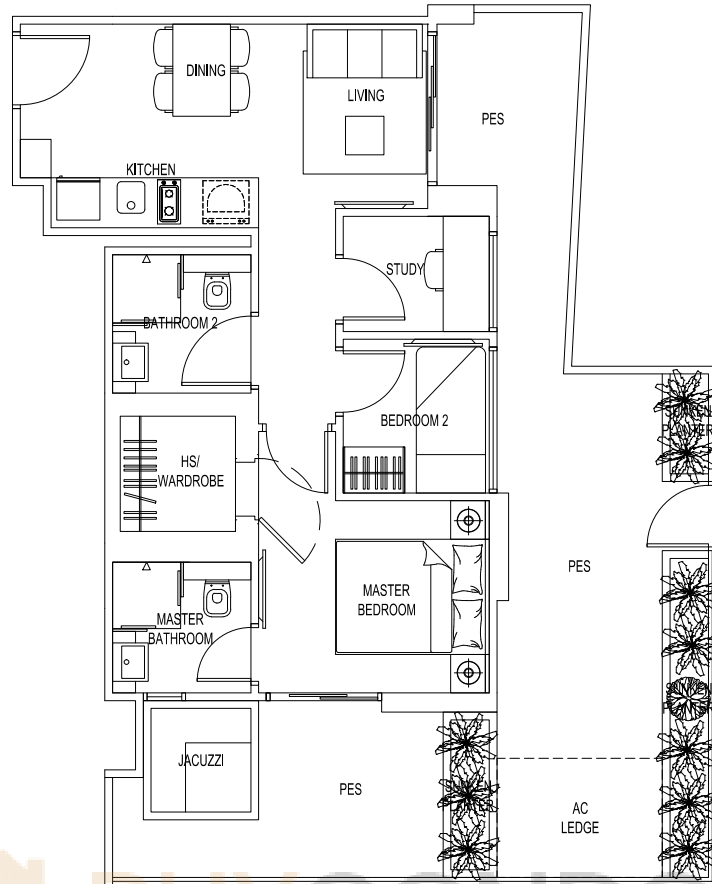

B2-G

AREA: 82.0 sqm

UNIT: #07-02

7TH STOREY

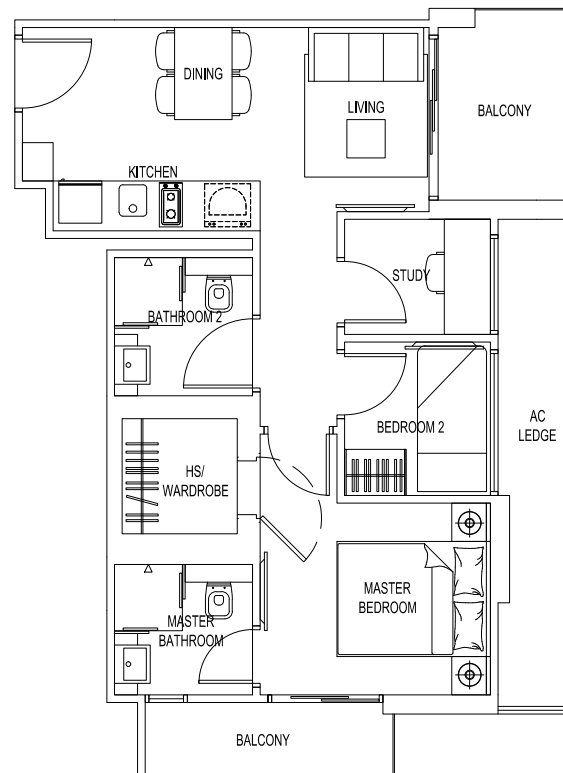

B2

AREA: 62.0 sqm

UNIT: #08-02, #09-02,
#10-02, #11-02, #12-02,
#13-02, #14-02, #15-02,
#16-02, #17-02, #18-02,
#19-02, #20-02, #21-02,
#22-02, #23-02, #24-02,
#25-02, #26-02, #27-02
8TH TO 27TH STOREY

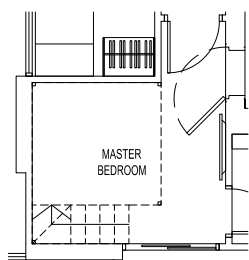

SUGGESTED LOFT LAYOUT

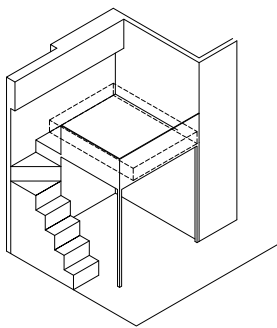

SUGGESTED LOFT LAYOUT ISOMETRIC VIEW

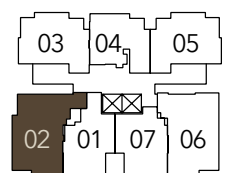

All floor area indicated are inclusive of aircon ledge, balcony, open balcony, roof terrace and private enclosed space (PES), where applicable. Areas are estimates only and subject to final survey. All floor plans are subject to changes as may be required or approved by the relevant authorities. Furniture shown are indicative only and are not provided. Please refer to the floor plans in the Sales & Purchase Agreement for details.



2-BEDROOM

A1-A

AREA: 47.0 sqm

UNIT: #27-07

27TH STOREY

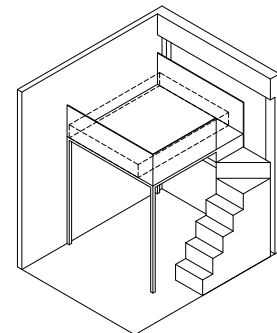
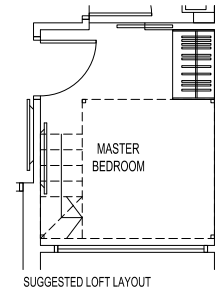
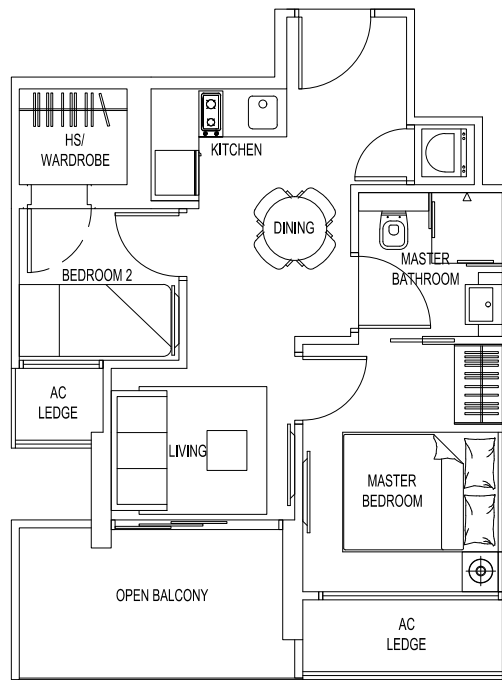
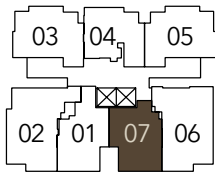

SUGGESTED LOFT LAYOUT ISOMETRIC VIEW



A2-A

AREA: 47.0 sqm

UNIT: #27-01

27TH STOREY

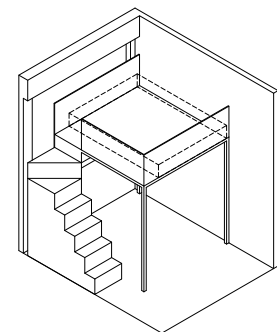
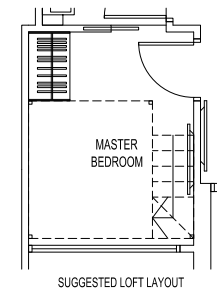
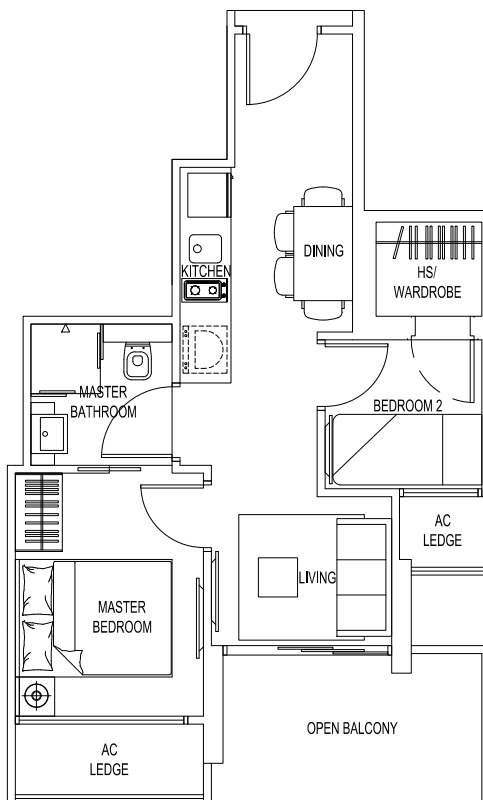
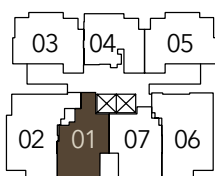

SUGGESTED LOFT LAYOUT ISOMETRIC VIEW



All floor area indicated are inclusive of aircon ledge, balcony, open balcony, roof terrace and private enclosed space (PES), where applicable. Areas are estimates only and subject to final survey. All floor plans are subject to changes as may be required or approved by the relevant authorities. Furniture shown are indicative only and are not provided. Please refer to the floor plans in the Sales & Purchase Agreement for details.

PENTHOUSE

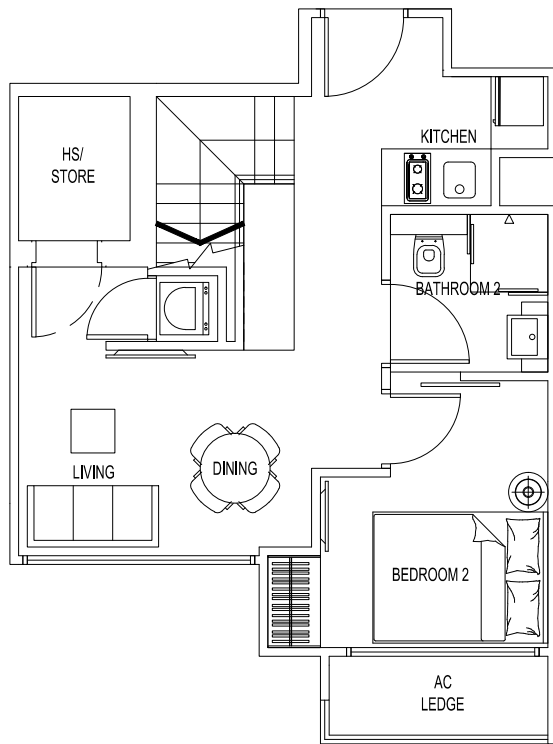

A1-P

AREA: 75.0 sqm

UNIT: #28-07

28TH-29TH STOREY

LOWER PENTHOUSE UNIT

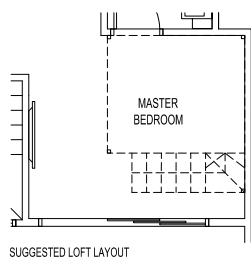

SUGGESTED LOFT LAYOUT

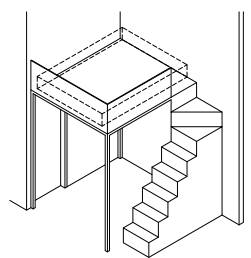

SUGGESTED LOFT LAYOUT ISOMETRIC VIEW

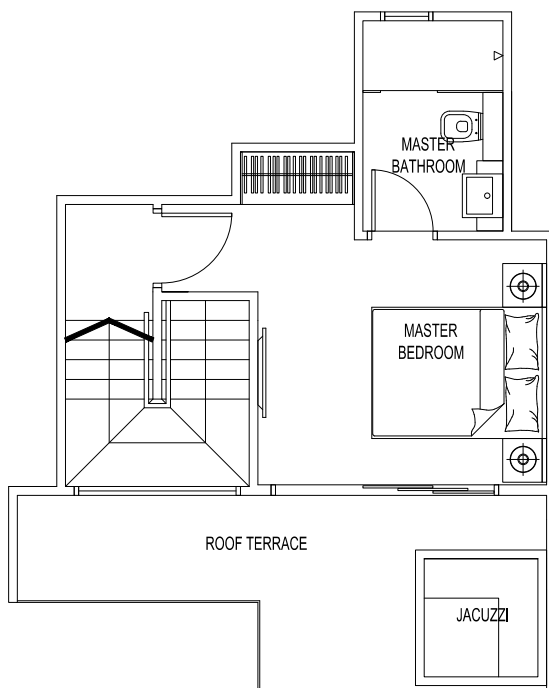

A1-UP

UPPER PENTHOUSE UNIT

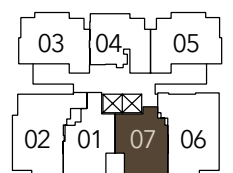

All floor area indicated are inclusive of aircon ledge, balcony, open balcony, roof terrace and private enclosed space (PES), where applicable. Areas are estimates only and subject to final survey. All floor plans are subject to changes as may be required or approved by the relevant authorities. Furniture shown are indicative only and are not provided. Please refer to the floor plans in the Sales & Purchase Agreement for details.



PENTHOUSE

A2-P

AREA: 74.0 sqm

UNIT: #28-01

28TH-29TH STOREY

LOWER PENTHOUSE UNIT

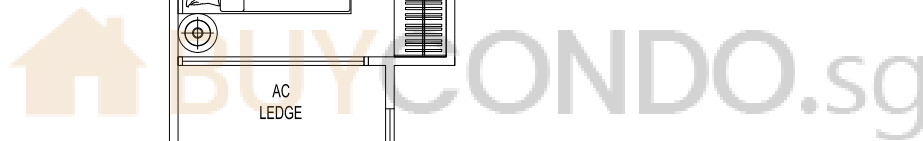
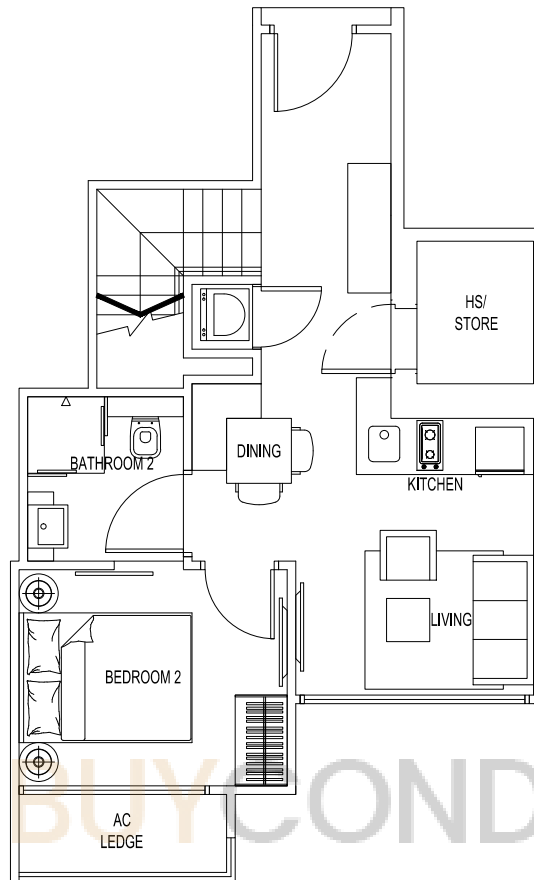

A2-UP

UPPER PENTHOUSE UNIT

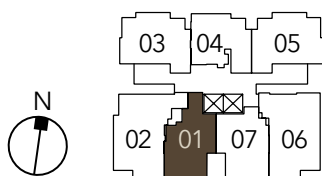
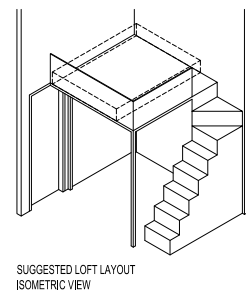
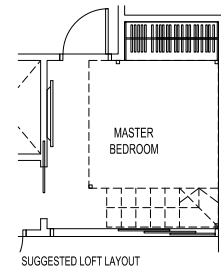
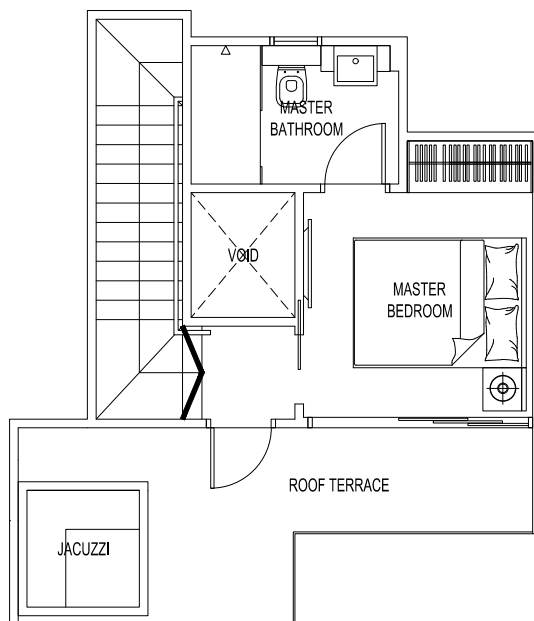

All floor area indicated are inclusive of aircon ledge, balcony, open balcony, roof terrace and private enclosed space (PES), where applicable. Areas are estimates only and subject to final survey. All floor plans are subject to changes as may be required or approved by the relevant authorities. Furniture shown are indicative only and are not provided. Please refer to the floor plans in the Sales & Purchase Agreement for details.

PENTHOUSE

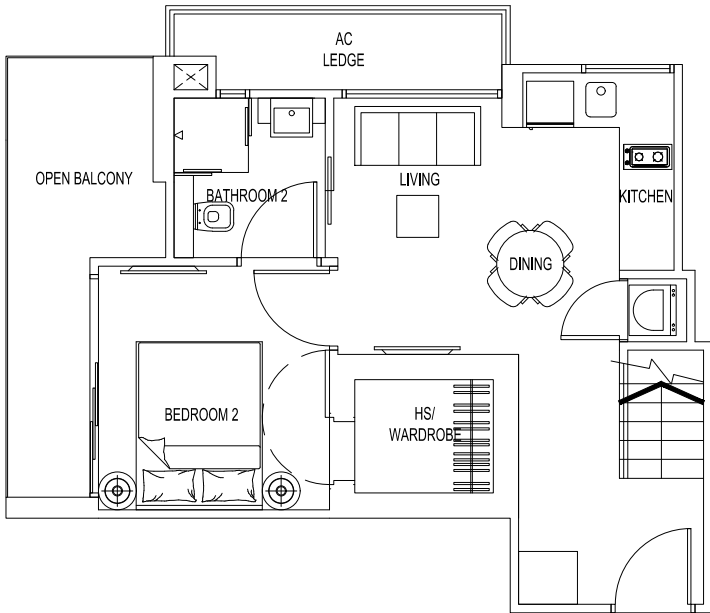

A3-P

AREA: 88.0 sqm

UNIT: #28-03

28TH-29TH STOREY

LOWER PENTHOUSE UNIT

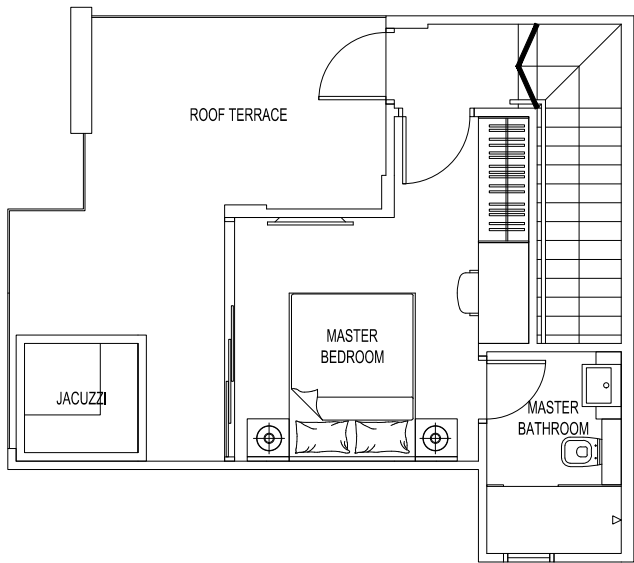

A3-UP

UPPER PENTHOUSE UNIT

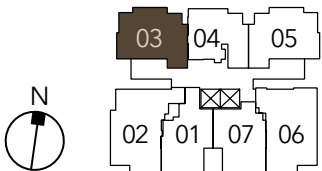
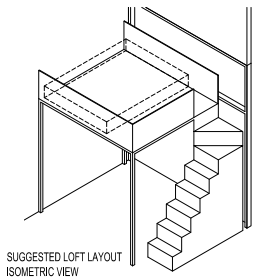
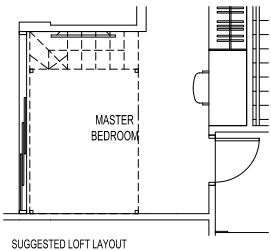

All floor area indicated are inclusive of aircon ledge, balcony, open balcony, roof terrace and private enclosed space (PES), where applicable. Areas are estimates only and subject to final survey. All floor plans are subject to changes as may be required or approved by the relevant authorities. Furniture shown are indicative only and are not provided. Please refer to the floor plans in the Sales & Purchase Agreement for details.



PENTHOUSE

A4-P

AREA: 84.0 sqm

UNIT: #28-04

28TH-29TH STOREY

LOWER PENTHOUSE UNIT

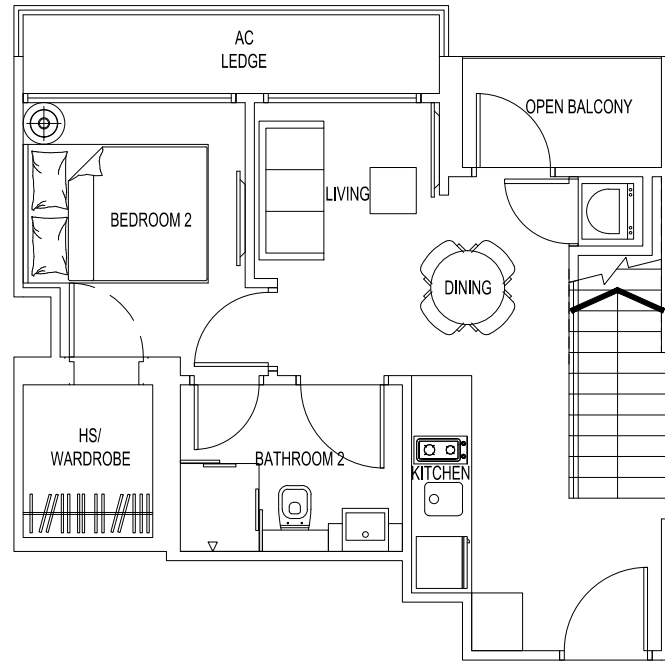

A4-UP

UPPER PENTHOUSE UNIT

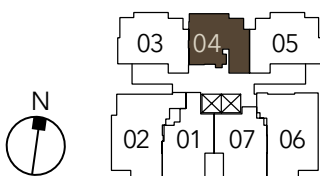
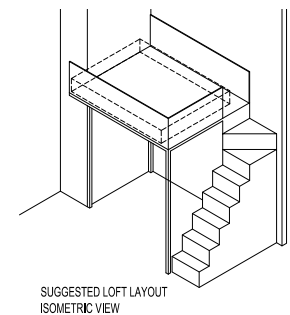
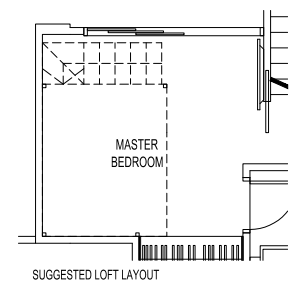
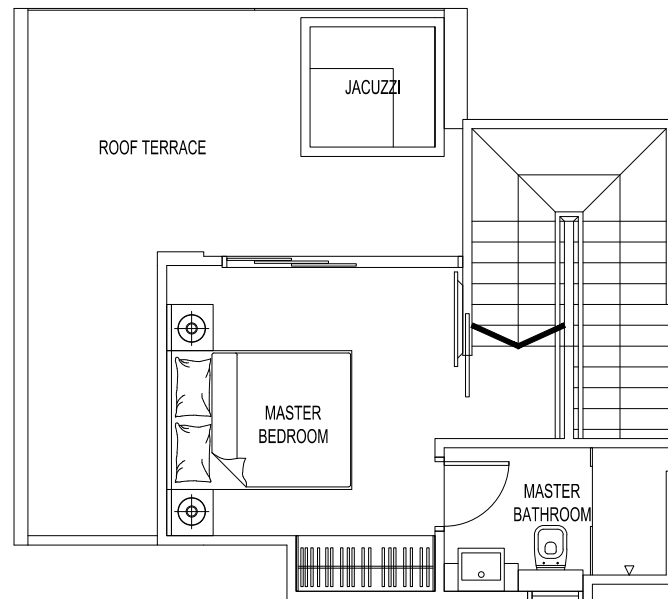

All floor area indicated are inclusive of aircon ledge, balcony, open balcony, roof terrace and private enclosed space (PES), where applicable. Areas are estimates only and subject to final survey. All floor plans are subject to changes as may be required or approved by the relevant authorities. Furniture shown are indicative only and are not provided. Please refer to the floor plans in the Sales & Purchase Agreement for details.

PENTHOUSE

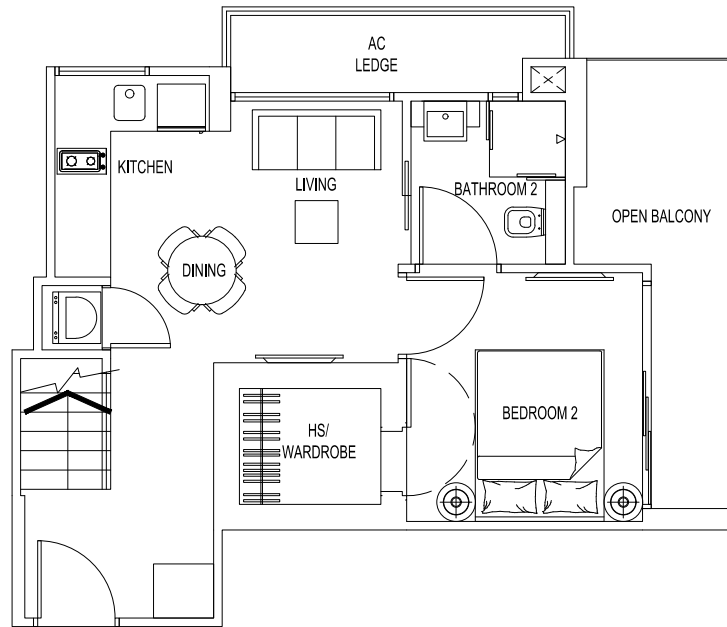

A5-P

AREA: 91.0 sqm

UNIT: #28-05

28TH-29TH STOREY

LOWER PENTHOUSE UNIT

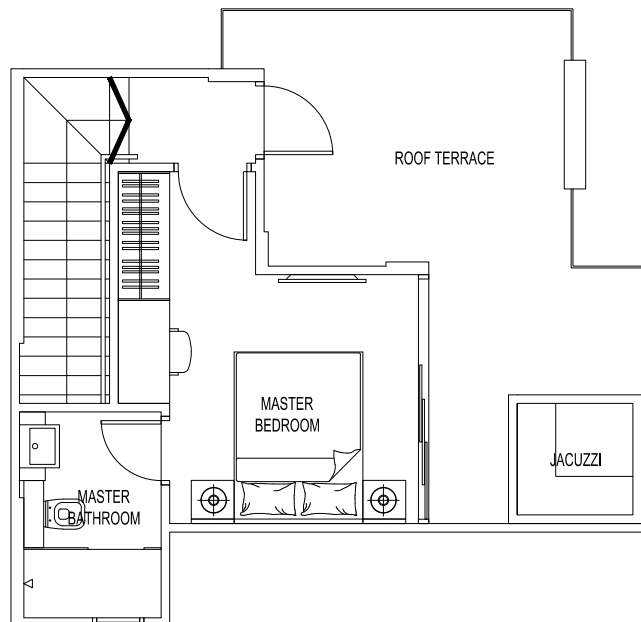

A5-UP

UPPER PENTHOUSE UNIT

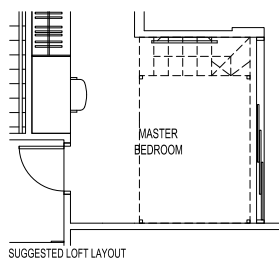

SUGGESTED LOFT LAYOUT

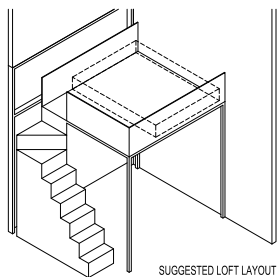

SUGGESTED LOFT LAYOUT ISOMETRIC VIEW

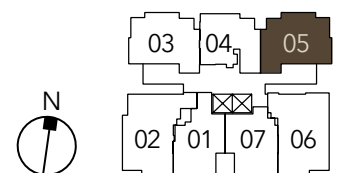

All floor area indicated are inclusive of aircon ledge, balcony, open balcony, roof terrace and private enclosed space (PES), where applicable. Areas are estimates only and subject to final survey. All floor plans are subject to changes as may be required or approved by the relevant authorities. Furniture shown are indicative only and are not provided. Please refer to the floor plans in the Sales & Purchase Agreement for details.



PENTHOUSE

B1-P

AREA: 101.0 sqm

UNIT: #28-06

28TH-29TH STOREY

LOWER PENTHOUSE UNIT

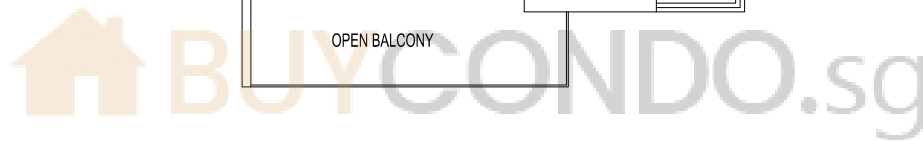
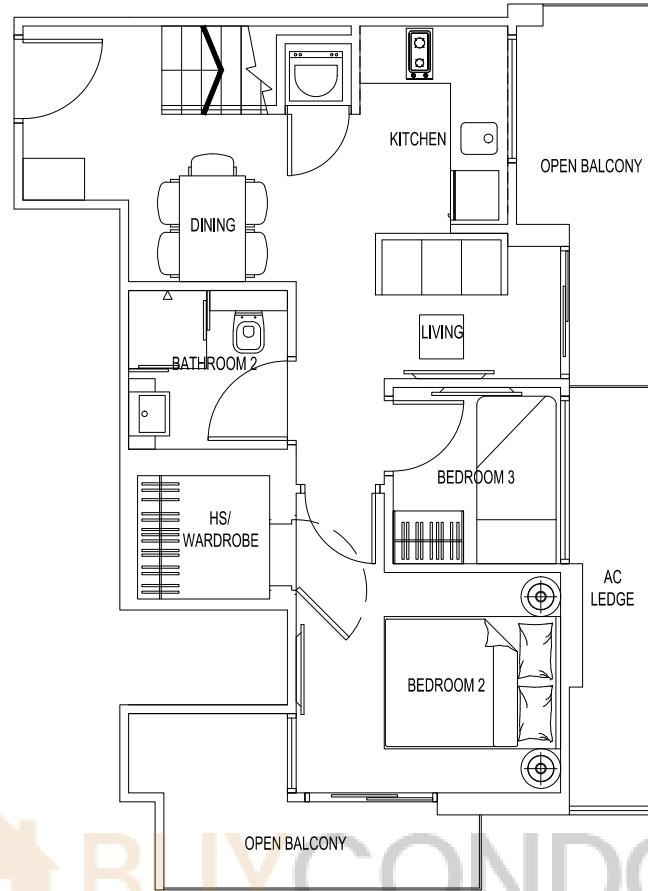

B1-UP

UPPER PENTHOUSE UNIT

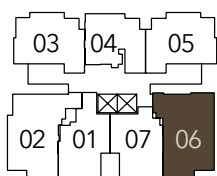
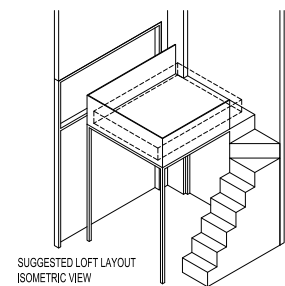
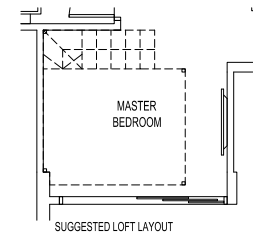
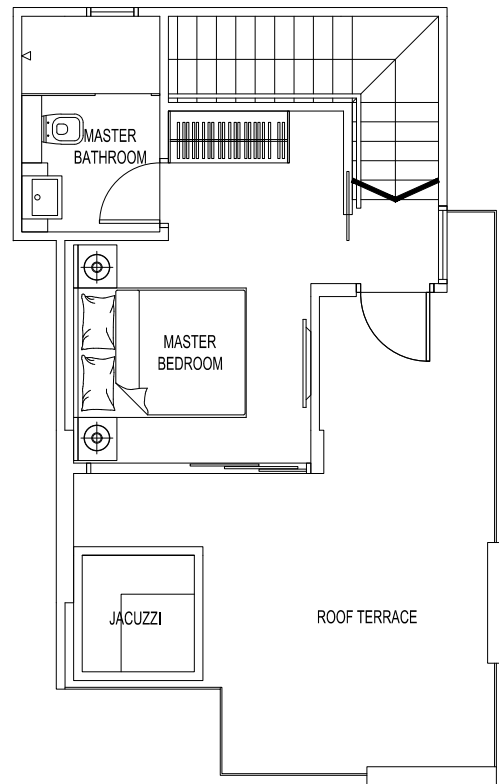

All floor area indicated are inclusive of aircon ledge, balcony, open balcony, roof terrace and private enclosed space (PES), where applicable. Areas are estimates only and subject to final survey. All floor plans are subject to changes as may be required or approved by the relevant authorities. Furniture shown are indicative only and are not provided. Please refer to the floor plans in the Sales & Purchase Agreement for details.

PENTHOUSE

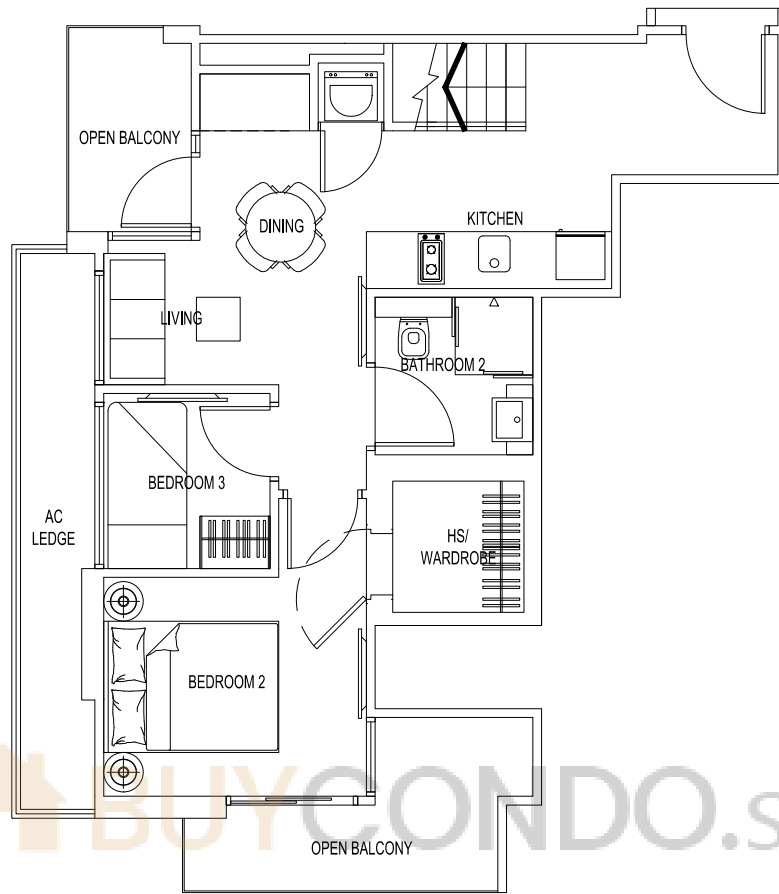

B2-P

AREA: 102.0 sqm

UNIT: #28-02

28TH-29TH STOREY

LOWER PENTHOUSE UNIT

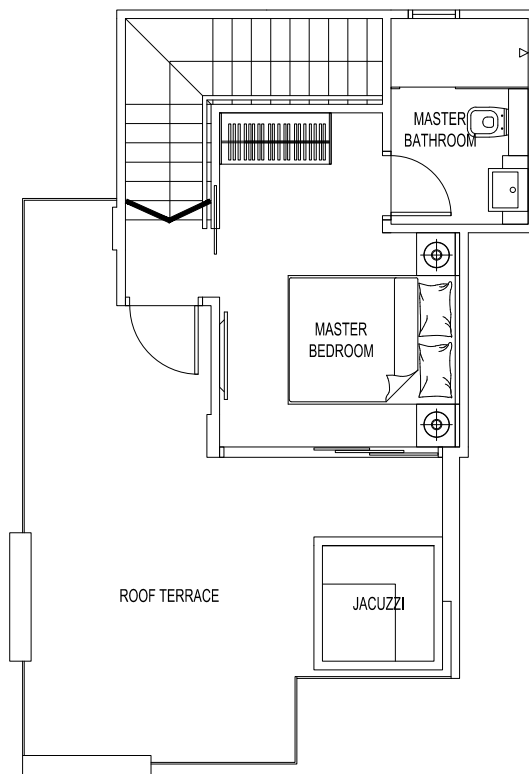
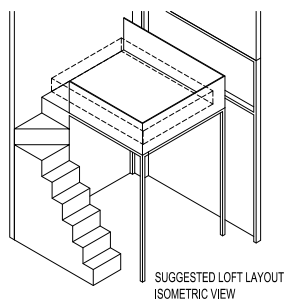
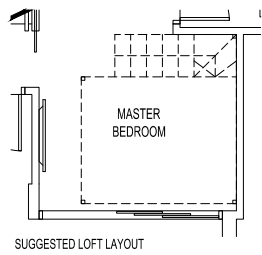

B2-UP

UPPER PENTHOUSE UNIT

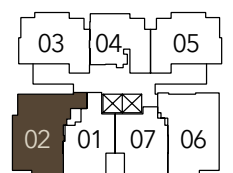

All floor area indicated are inclusive of aircon ledge, balcony, open balcony, roof terrace and private enclosed space (PES), where applicable. Areas are estimates only and subject to final survey. All floor plans are subject to changes as may be required or approved by the relevant authorities. Furniture shown are indicative only and are not provided. Please refer to the floor plans in the Sales & Purchase Agreement for details.

