

LEVEL ONE

3-BEDROOM

TYPE A

AREA - 174 SQM

#01-01

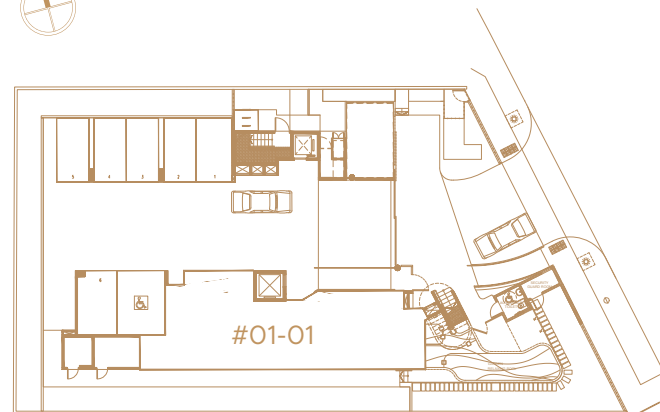
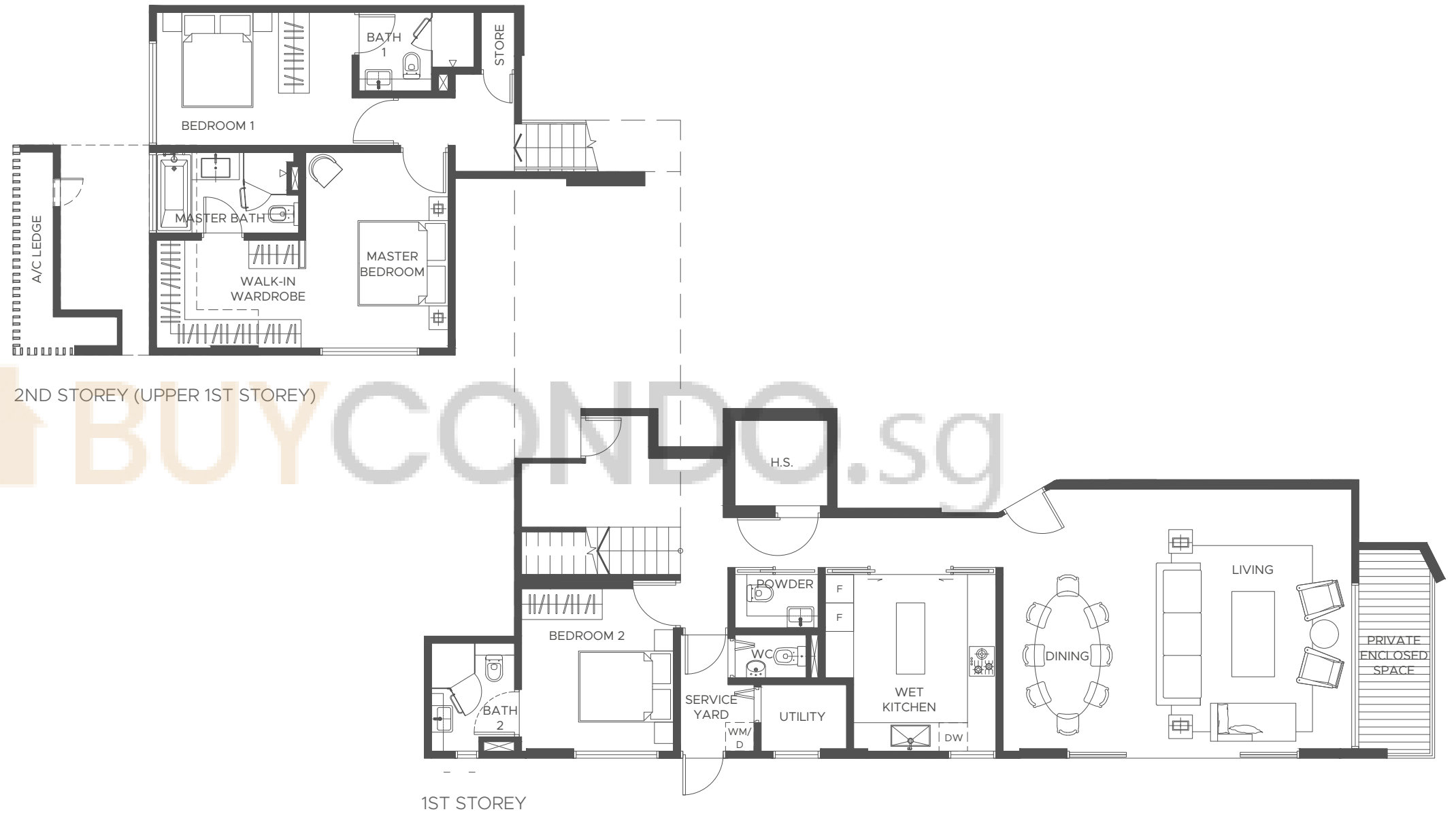

0m 5m 10m
SCALE 1:75

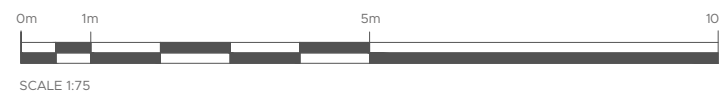

APPLIANCE LEGEND
 F - FREESTANDING/ INTEGRATED FRIDGE WM - WASHING MACHINE
 DW - INTEGRATED DISHWASHER D - TUMBLE DRYER

All areas inclusive of balconies, private enclosed spaces (PES), planters, and strata void areas, if any. Furniture is indicative only and not provided for. All plans and layouts are not drawn to scale and are subject to any amendments required by the developer and/or approved by the relevant authorities or required by the architect and notified to the developer after the date of print. All floor areas and other measurements indicated are approximate measurements only and are subject to final government re-survey. The PES and balcony shall not be enclosed unless with the approved balcony screen. For an illustration of the approved balcony screen, please refer to the diagram annexed hereto as "Annexure A"



LEVEL TWO

3-BEDROOM

TYPE B

AREA - 171 SQM

#02-01

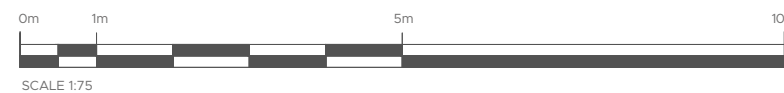
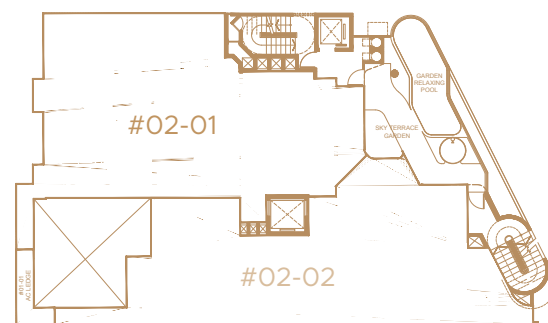
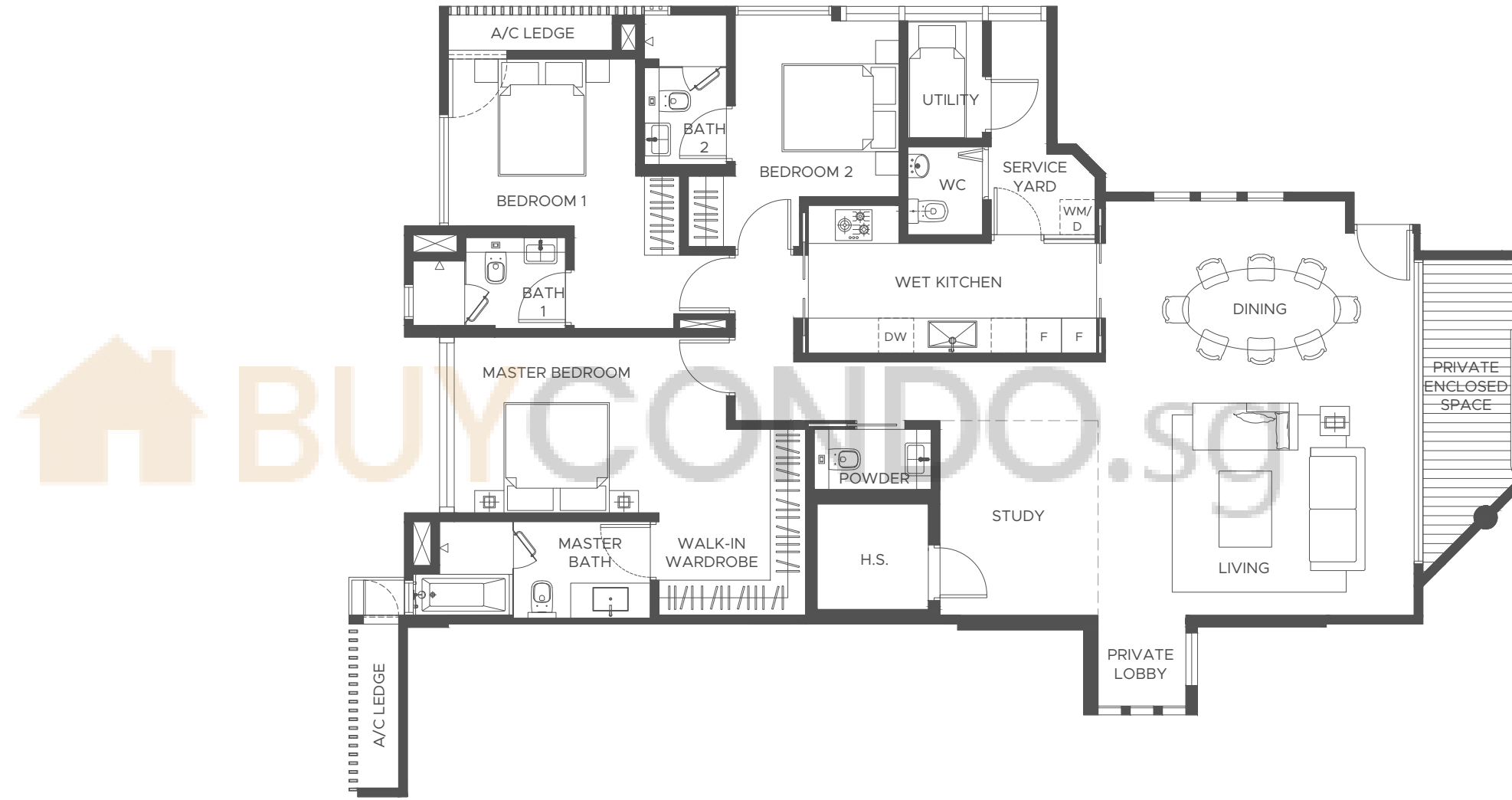

APPLIANCE LEGEND
 F - FREESTANDING/ INTEGRATED FRIDGE WM - WASHING MACHINE
 DW - INTEGRATED DISHWASHER D - TUMBLE DRYER

All areas inclusive of balconies, private enclosed spaces (PES), planters, and strata void areas, if any. Furniture is indicative only and not provided for. All plans and layouts are not drawn to scale and are subject to any amendments required by the developer and/or approved by the relevant authorities or required by the architect and notified to the developer after the date of print. All floor areas and other measurements indicated are approximate measurements only and are subject to final government re-survey. The PES and balcony shall not be enclosed unless with the approved balcony screen. For an illustration of the approved balcony screen, please refer to the diagram annexed hereto as "Annexure A"



LEVEL TWO

3-BEDROOM

TYPE C

AREA - 152 SQM

#02-02

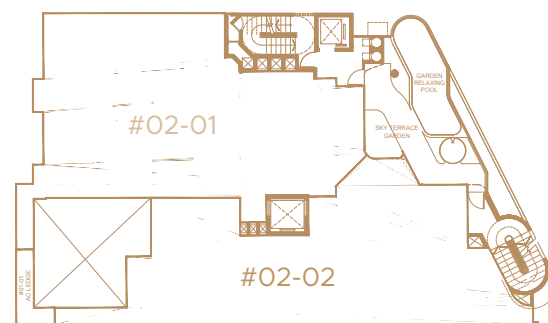
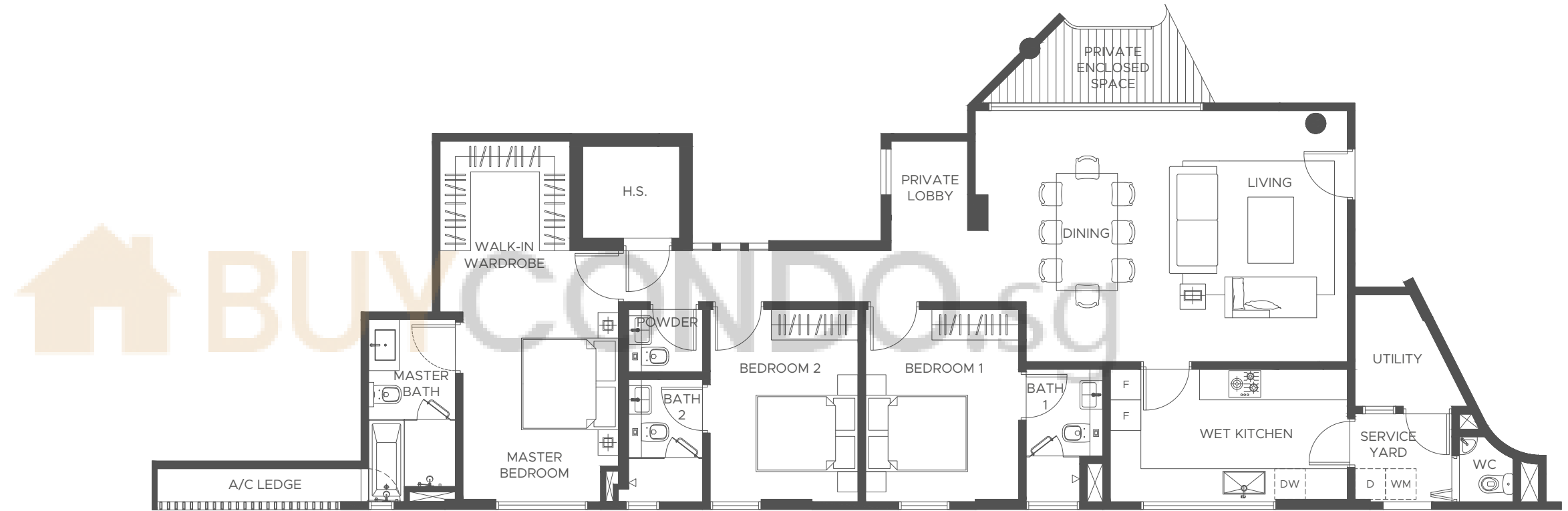

SCALE 1:75

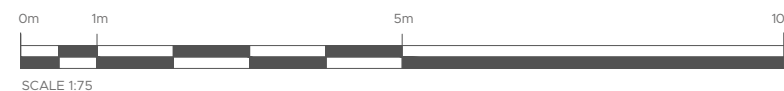

SCALE 1:75

APPLIANCE LEGEND

- F - FREESTANDING/ INTEGRATED FRIDGE
- DW - INTEGRATED DISHWASHER
- WM - WASHING MACHINE
- D - TUMBLE DRYER

All areas inclusive of balconies, private enclosed spaces (PES), planters, and strata void areas, if any. Furniture is indicative only and not provided for. All plans and layouts are not drawn to scale and are subject to any amendments required by the developer and/or approved by the relevant authorities or required by the architect and notified to the developer after the date of print. All floor areas and other measurements indicated are approximate measurements only and are subject to final government re-survey. The PES and balcony shall not be enclosed unless with the approved balcony screen. For an illustration of the approved balcony screen, please refer to the diagram annexed hereto as "Annexure A"



LEVEL THREE

4-BEDROOM

TYPE D

AREA - 256 SQM

#03-01

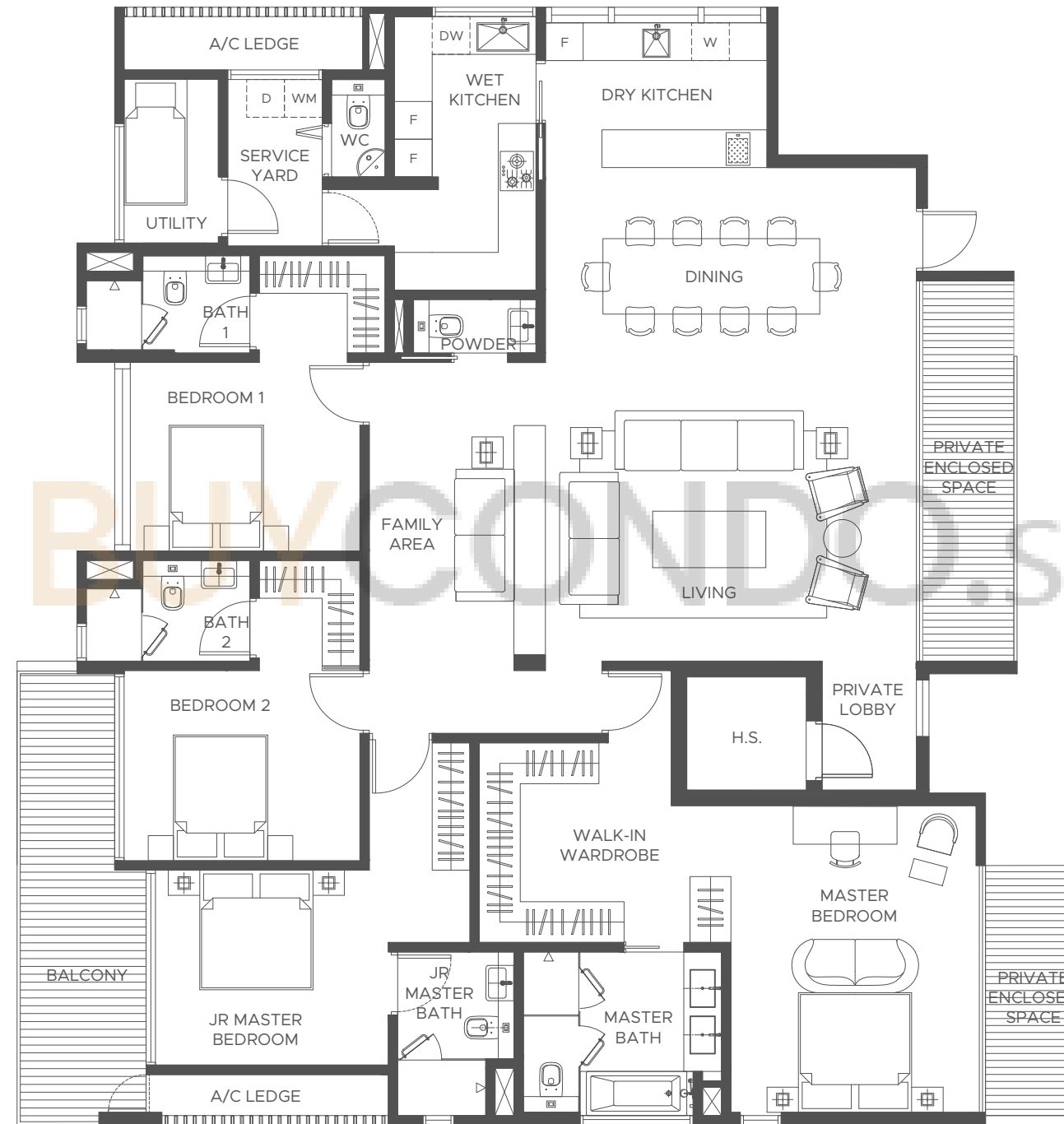

APPLIANCE LEGEND

- F - FREESTANDING/ INTEGRATED FRIDGE
- DW - INTEGRATED DISHWASHER
- W - UNDERCOUNTER WINE UNIT
- WM - WASHING MACHINE
- D - TUMBLE DRYER

All areas inclusive of balconies, private enclosed spaces (PES), planters, and strata void areas, if any. Furniture is indicative only and not provided for. All plans and layouts are not drawn to scale and are subject to any amendments required by the developer and/or approved by the relevant authorities or required by the architect and notified to the developer after the date of print. All floor areas and other measurements indicated are approximate measurements only and are subject to final government re-survey. The PES and balcony shall not be enclosed unless with the approved balcony screen. For an illustration of the approved balcony screen, please refer to the diagram annexed hereto as "Annexure A"

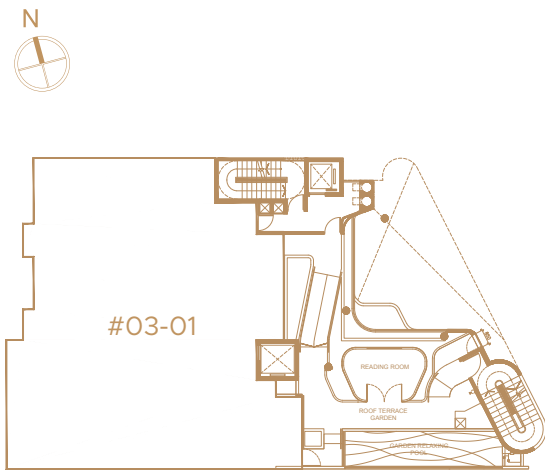

0m 5m 10m
SCALE 1:75

0m 1m 5m 10m
SCALE 1:75



LEVEL FOUR

4-BEDROOM

TYPE E

AREA - 254 SQM

#04-01

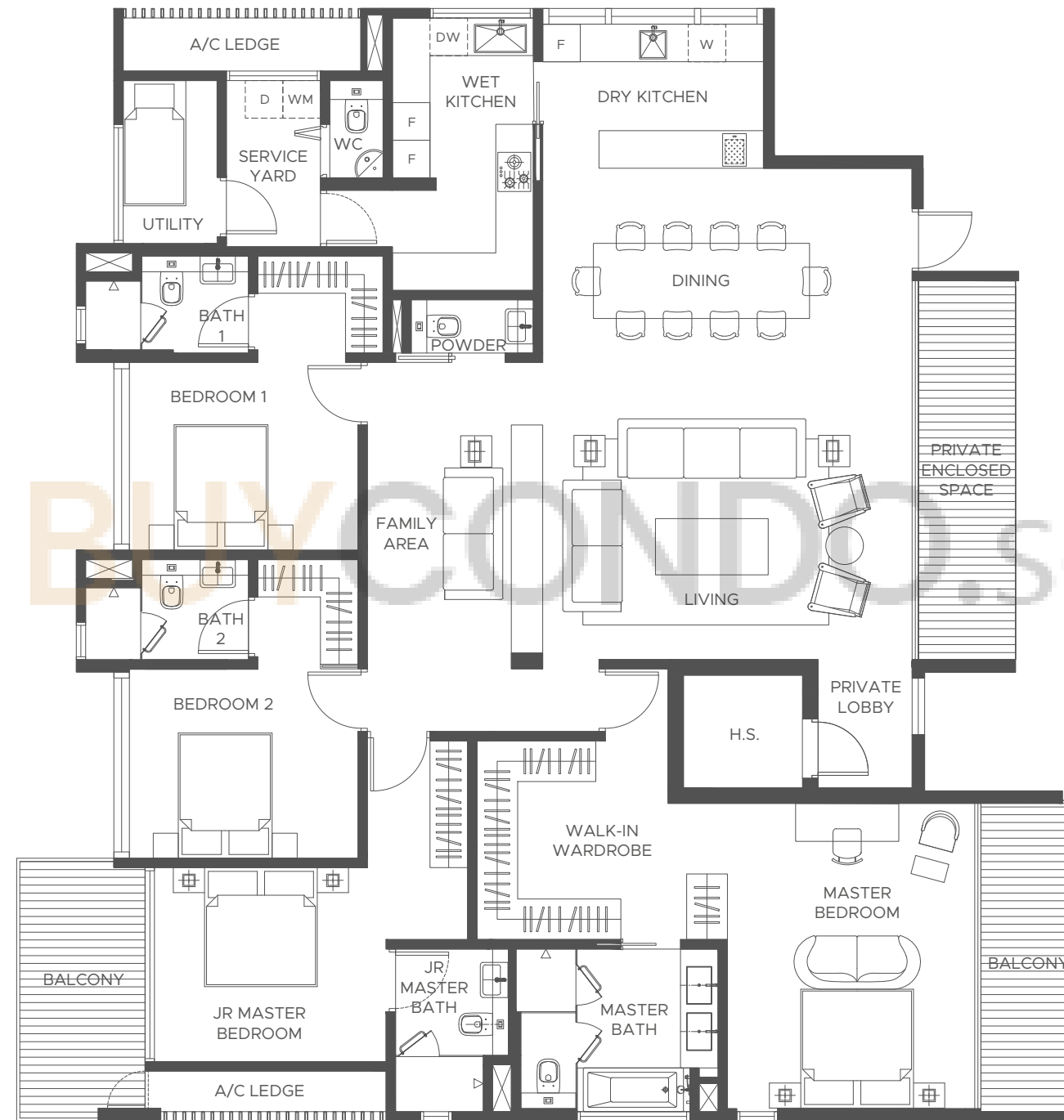

APPLIANCE LEGEND

- F - FREESTANDING/ INTEGRATED FRIDGE
- DW - INTEGRATED DISHWASHER
- W - UNDERCOUNTER WINE UNIT
- WM - WASHING MACHINE
- D - TUMBLE DRYER

All areas inclusive of balconies, private enclosed spaces (PES), planters, and strata void areas, if any. Furniture is indicative only and not provided for. All plans and layouts are not drawn to scale and are subject to any amendments required by the developer and/or approved by the relevant authorities or required by the architect and notified to the developer after the date of print. All floor areas and other measurements indicated are approximate measurements only and are subject to final government re-survey. The PES and balcony shall not be enclosed unless with the approved balcony screen. For an illustration of the approved balcony screen, please refer to the diagram annexed hereto as "Annexure A"

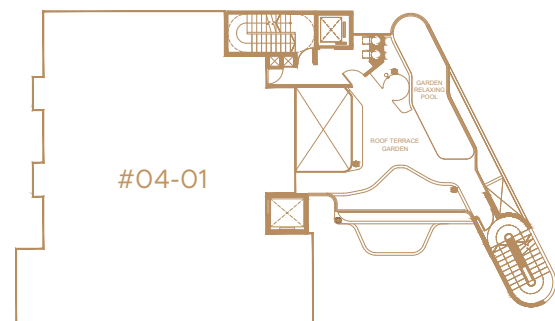

0m 5m 10m
SCALE 1:75

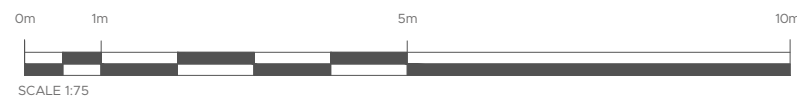

LEVEL FIVE

4-BEDROOM

TYPE E

AREA - 237 SQM

#05-01

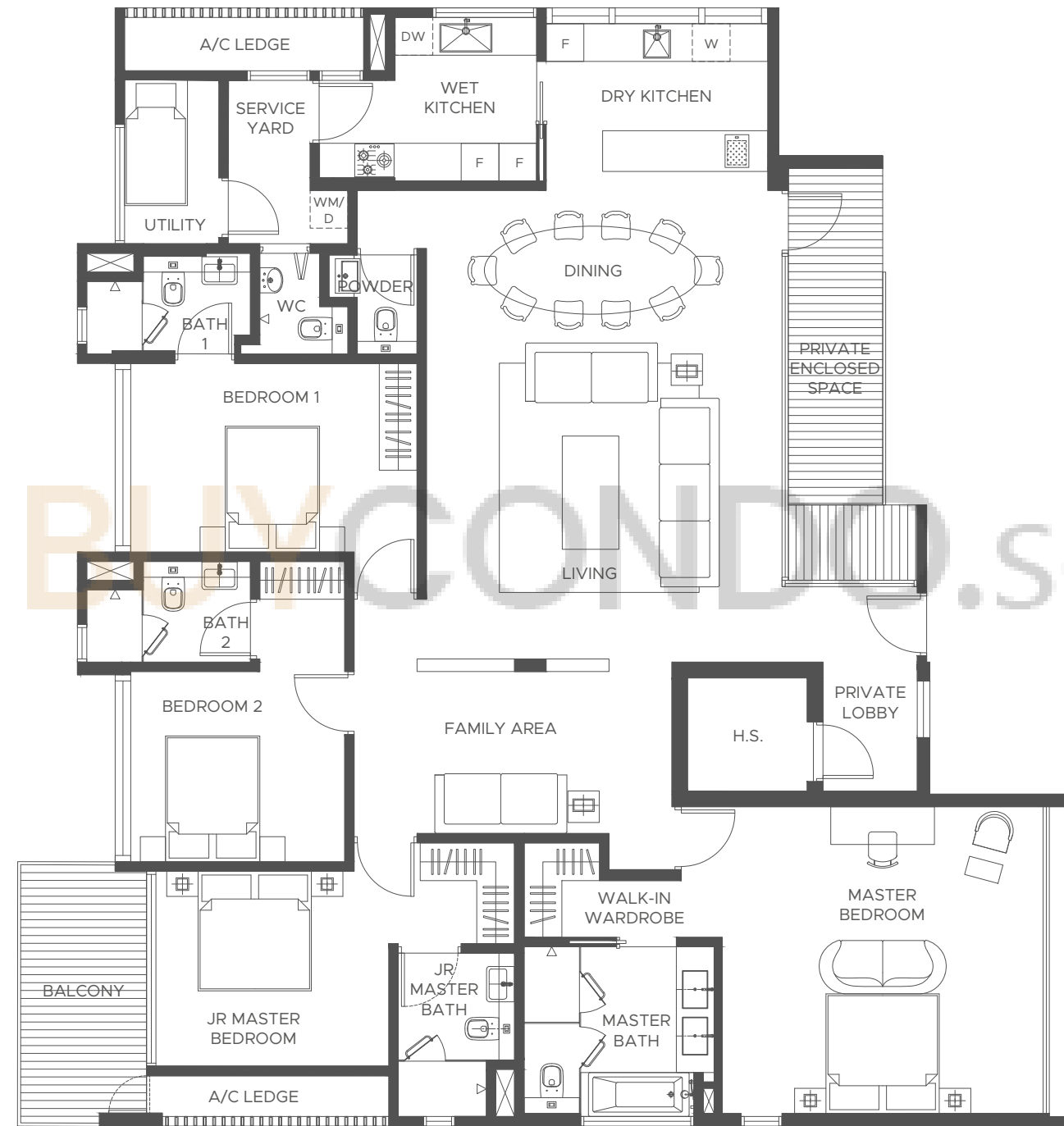

APPLIANCE LEGEND

- F - FREESTANDING/ INTEGRATED FRIDGE
- DW - INTEGRATED DISHWASHER
- W - UNDERCOUNTER WINE UNIT
- WM - WASHING MACHINE
- D - TUMBLE DRYER

All areas inclusive of balconies, private enclosed spaces (PES), planters, and strata void areas, if any. Furniture is indicative only and not provided for. All plans and layouts are not drawn to scale and are subject to any amendments required by the developer and/or approved by the relevant authorities or required by the architect and notified to the developer after the date of print. All floor areas and other measurements indicated are approximate measurements only and are subject to final government re-survey. The PES and balcony shall not be enclosed unless with the approved balcony screen. For an illustration of the approved balcony screen, please refer to the diagram annexed hereto as "Annexure A"

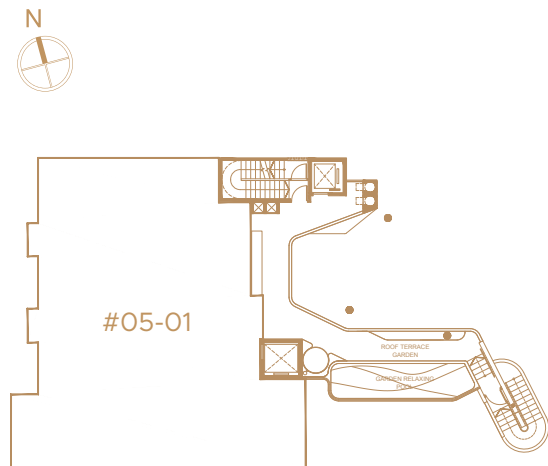

SCALE 1:75

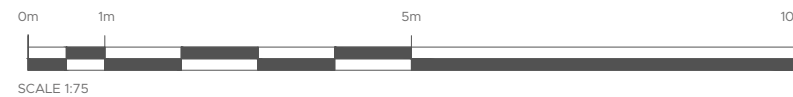

SCALE 1:75



BALCONY SCREEN

ANNEXURE A

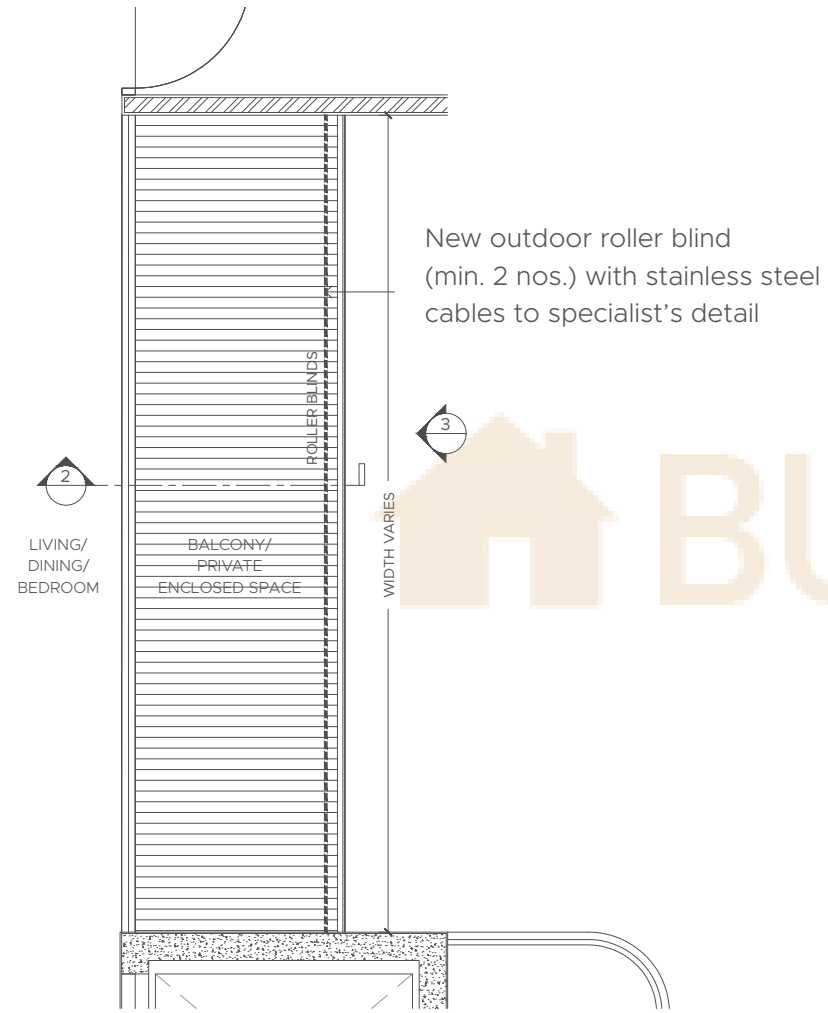

1 BALCONY/PRIVATE ENCLOSED SPACE - TYPICAL PLAN
1:25

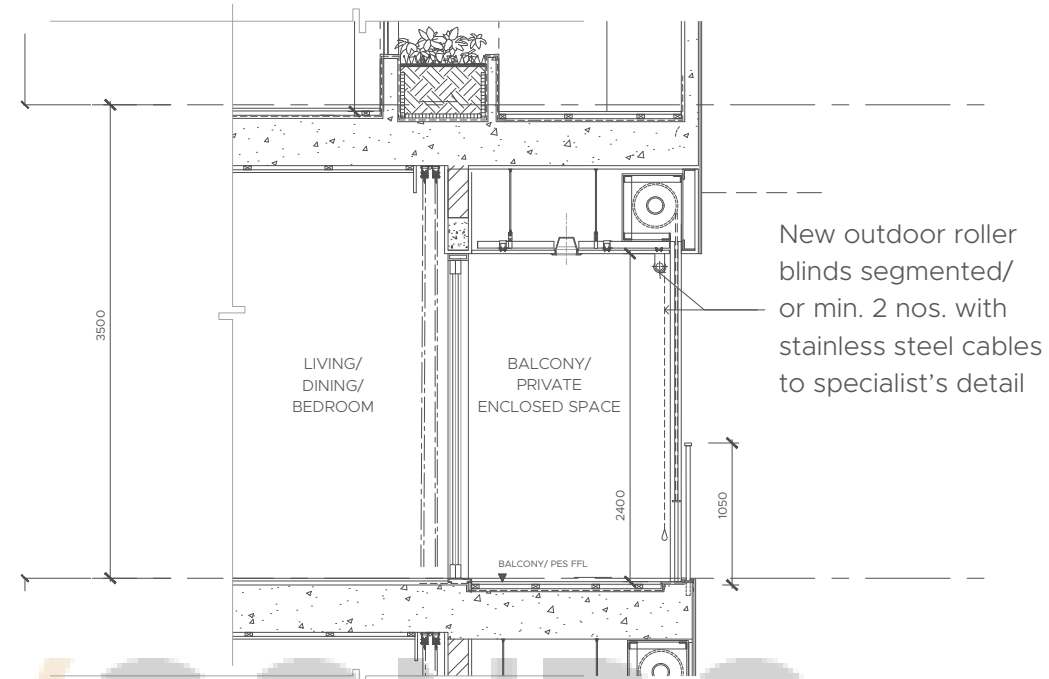

2 BALCONY/ PRIVATE ENCLOSED SPACE - TYPICAL SECTION
1:25

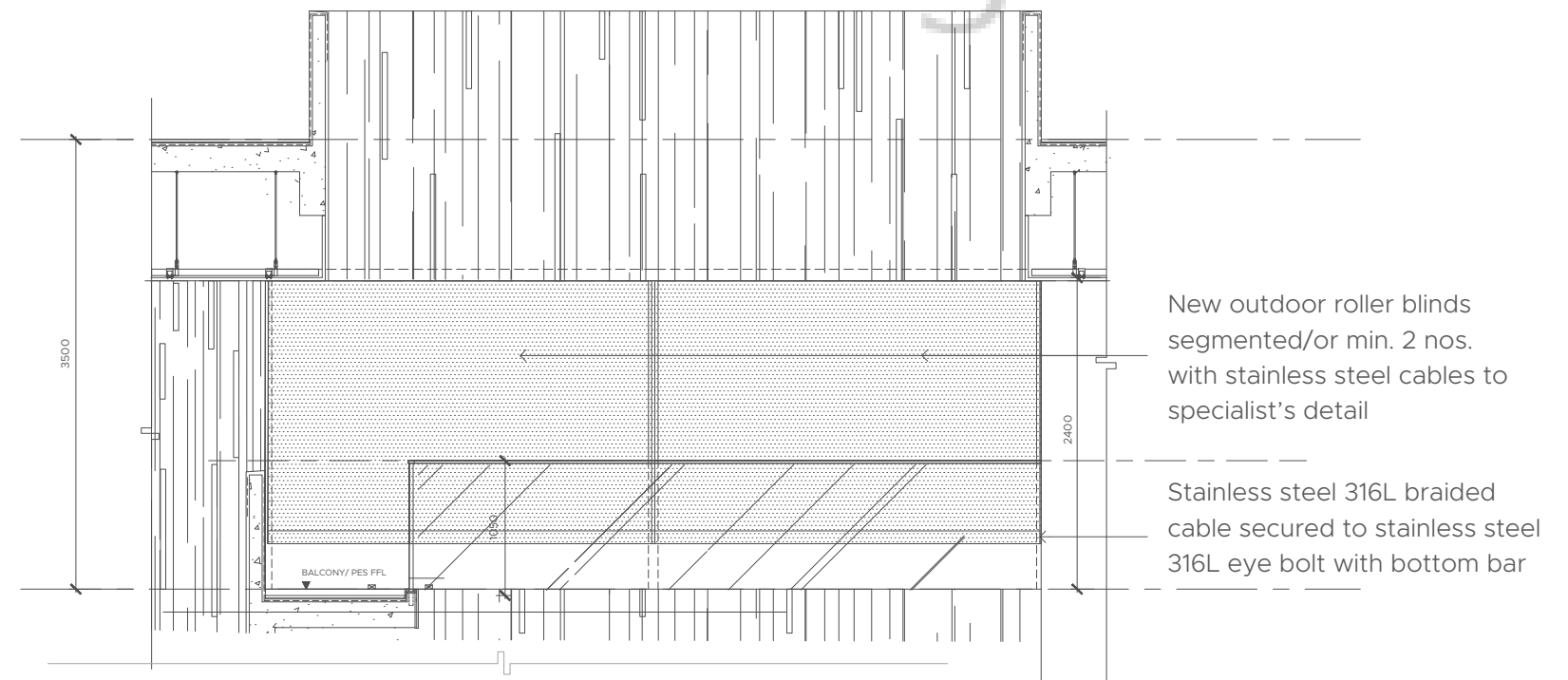

3 BALCONY/PRIVATE ENCLOSED SPACE - TYPICAL ELEVATION
1:25