

1-Bedroom

TYPE A-1G

Area: 46 sq m (include 3 sq m A/C LEDGE, 6 sq m PES)

Unit(s): #04-03*, #04-04, #04-09*, #04-14

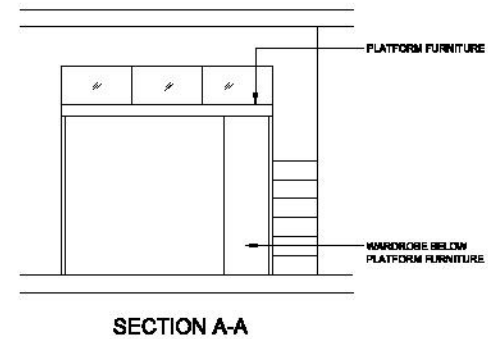
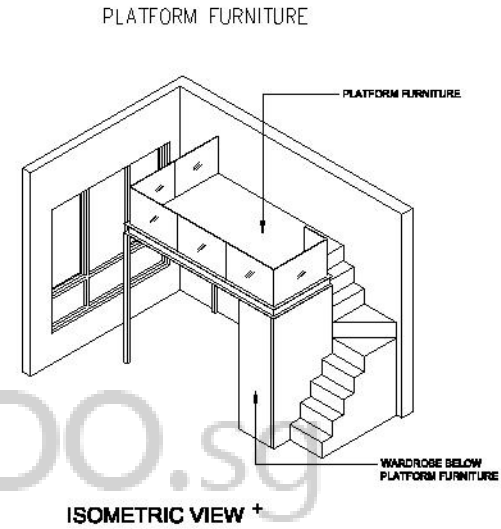
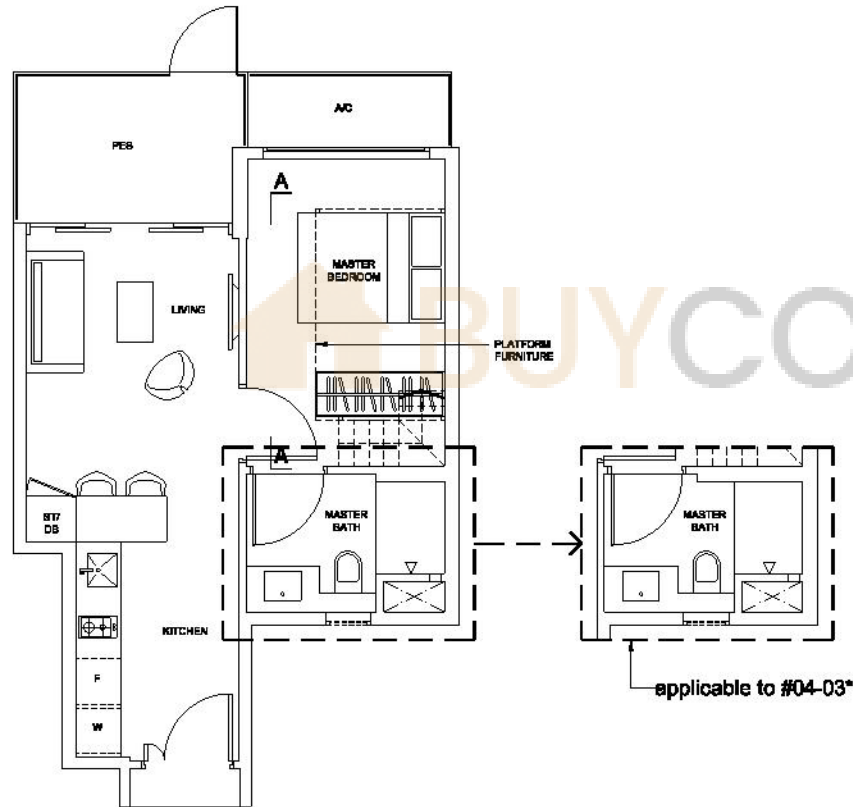

NOTE:

* units in mirror image

+ isometric views have excluded railings drawings

Plans are subject to change as may be required or approved by the relevant authorities. These are not drawn to scale and are for the purpose of visual presentation only. Indicated areas are estimates only and subject to final survey.

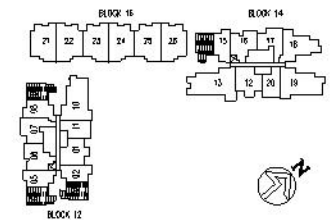

1-Bedroom + Study

TYPE AS-1G

Area: 51 sq m (include 3 sq m A/C LEDGE, 7 sq m PES)

Unit(s): #04-02*, #04-05, #04-15

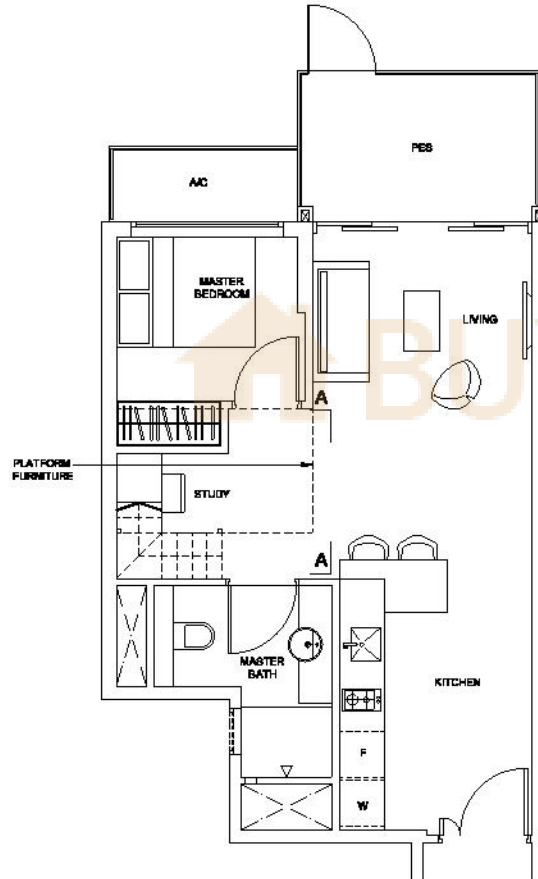

PLATFORM FURNITURE

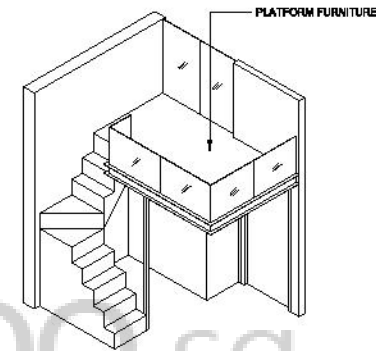

ISOMETRIC VIEW +

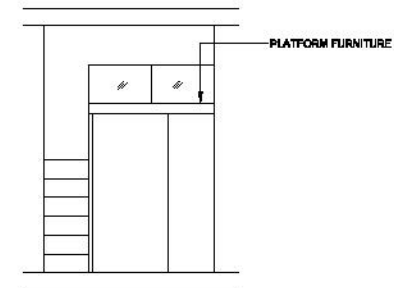

SECTION A-A

NOTE:

* units in mirror image

+ isometric views have excluded railings drawings

Plans are subject to change as may be required or approved by the relevant authorities. These are not drawn to scale and are for the purpose of visual presentation only. Indicated areas are estimates only and subject to final survey.

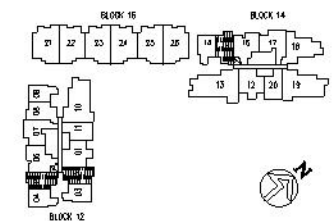

1-Bedroom + Study

TYPE AS-3G
 Area: 53 sq m (include 3 sq m A/C LEDGE, 6 sq m PES)
 Unit(s): #04-11, #04-20

TYPE AS-3PH
 Area: 53 sq m (include 3 sq m A/C LEDGE, 6 sq m BALCONY)
 Unit(s): #14-11, #14-20

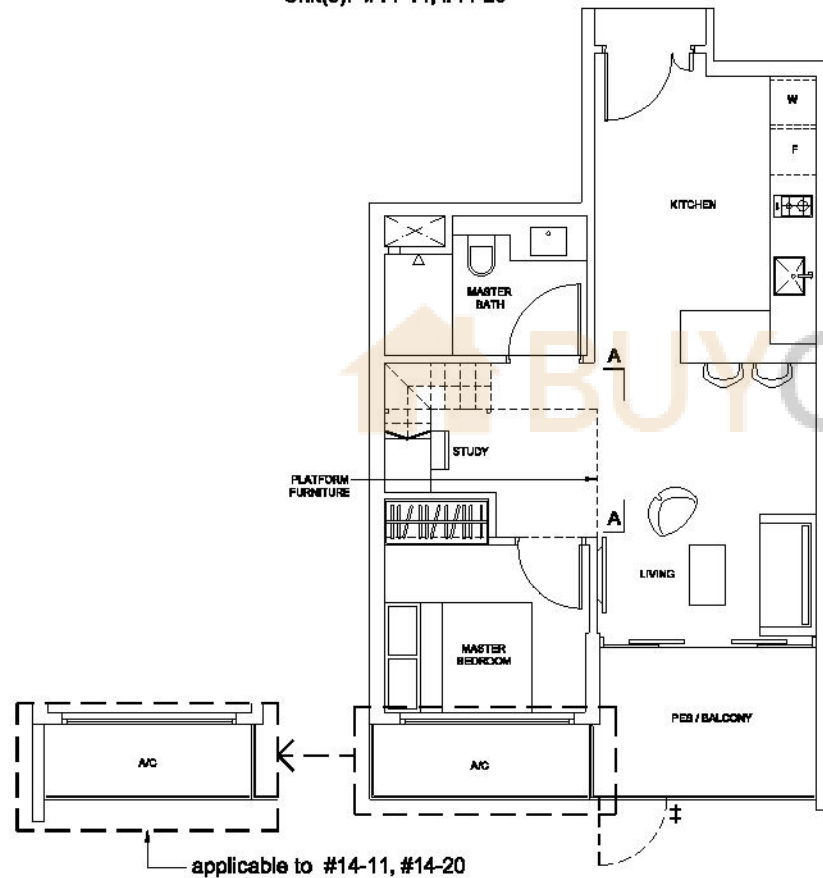

PLATFORM FURNITURE

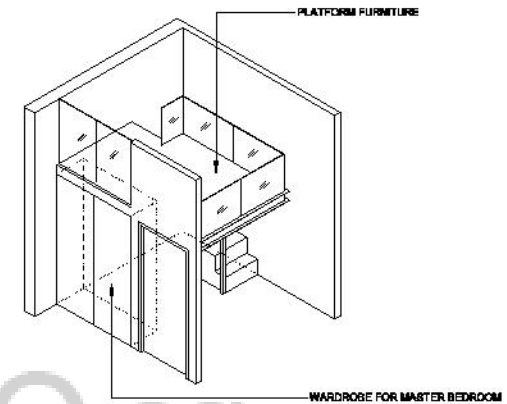

ISOMETRIC VIEW +

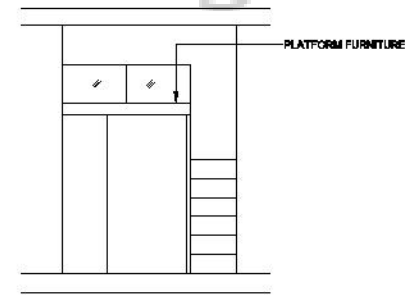

SECTION A-A

NOTE:
 + isometric views have excluded railings drawings
 ‡ applicable to type AS-3G only

Plans are subject to change as may be required or approved by the relevant authorities. These are not drawn to scale and are for the purpose of visual presentation only. Indicated areas are estimates only and subject to final survey.

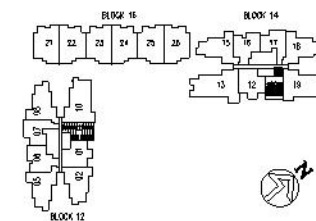

applicable to type AS-3PH

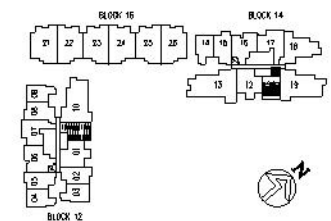

applicable to type AS-3G

2-Bedroom

TYPE B-1

Area: 85 sq m (include 3 sq m A/C LEDGE, 6 sq m BALCONY)

Unit(s): #05-07 TO # 13-07, #05-17 TO # 13-17

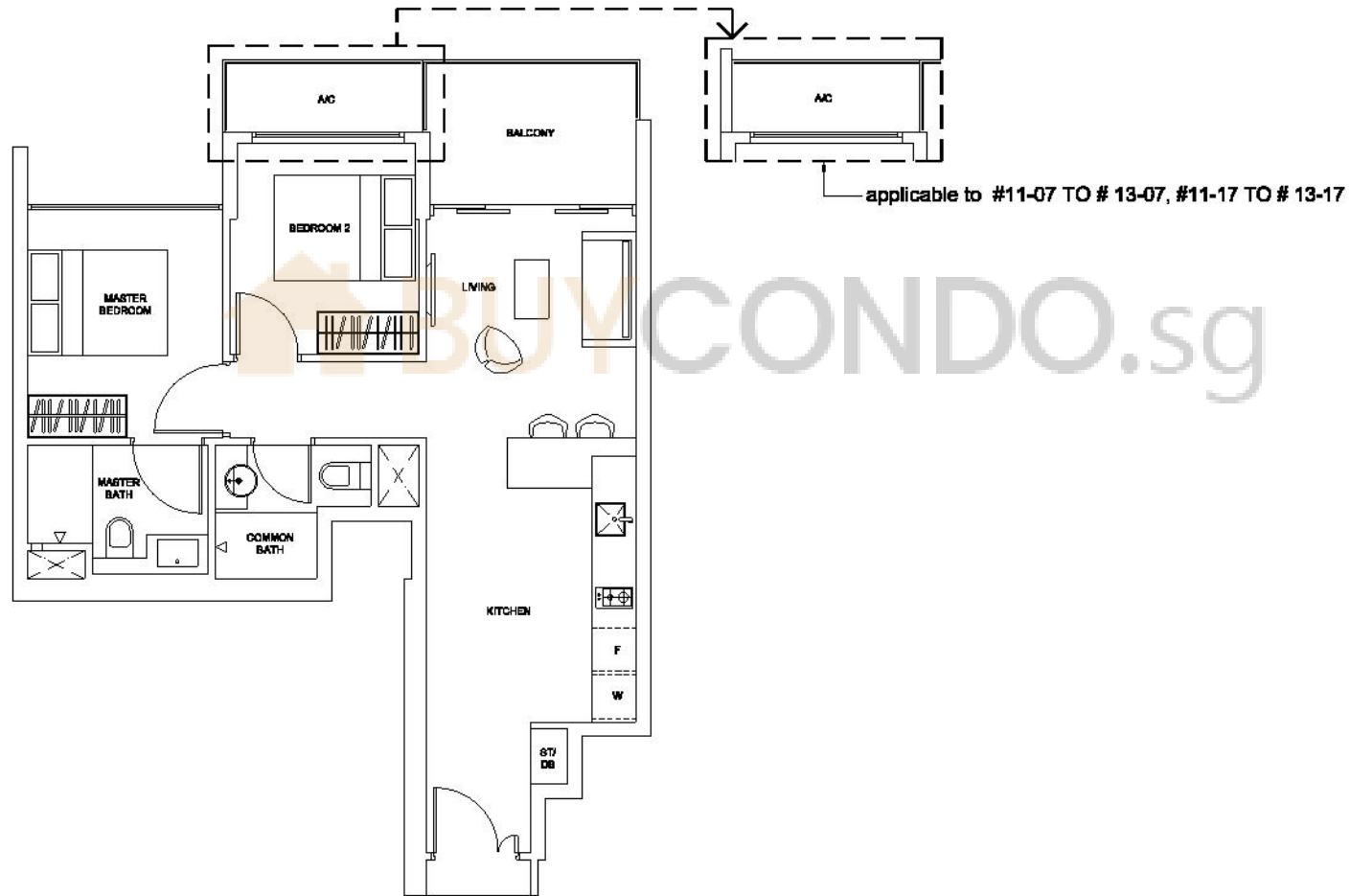

Plans are subject to change as may be required or approved by the relevant authorities. These are not drawn to scale and are for the purpose of visual presentation only. Indicated areas are estimates only and subject to final survey.

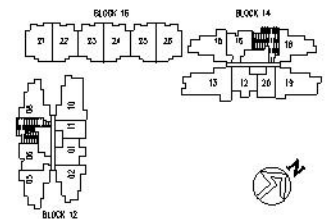

2-Bedroom + Study

TYPE BS-1

Area: 66 sq m (include 3 sq m A/C LEDGE, 6 sq m BALCONY)

Unit(s): #05-06 TO #13-06, #05-16 TO #13-16

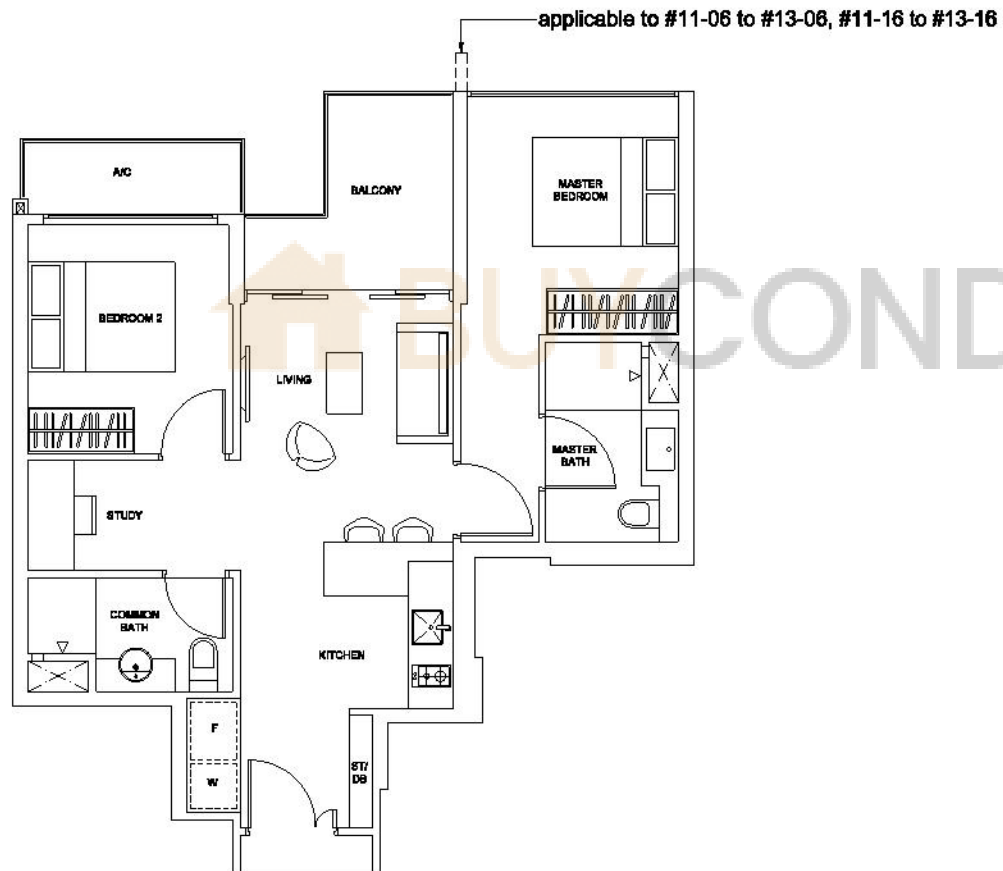

Plans are subject to change as may be required or approved by the relevant authorities. These are not drawn to scale and are for the purpose of visual presentation only. Indicated areas are estimates only and subject to final survey.

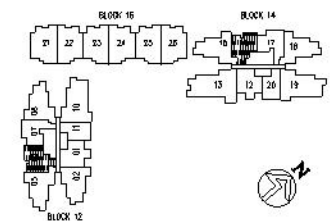

3-Bedroom

TYPE C-1
Area: 86 sq m (include 7 sq m A/C LEDGE, 7 sq m BALCONY)
Unit(s): #05-05 TO #13-05, #05-15 TO #10-15

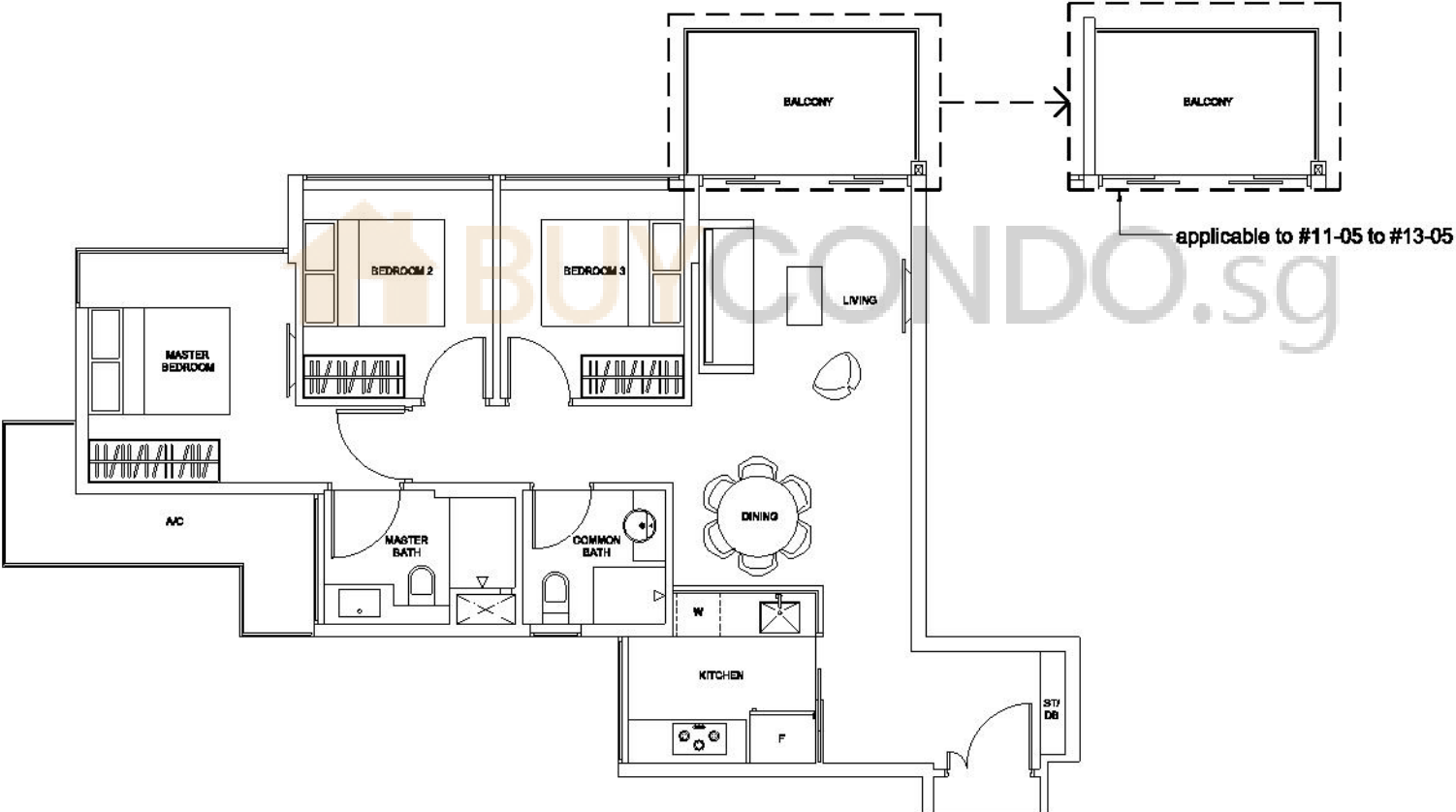

Plans are subject to change as may be required or approved by the relevant authorities. These are not drawn to scale and are for the purpose of visual presentation only. Indicated areas are estimates only and subject to final survey.

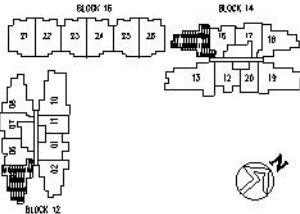

3-Bedroom

TYPE C-1a
Area: 93 sq m (include 7 sq m A/C LEDGE, 13 sq m BALCONY)
Unit(s): #11-15 TO #13-15

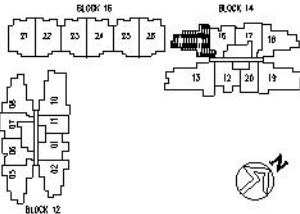
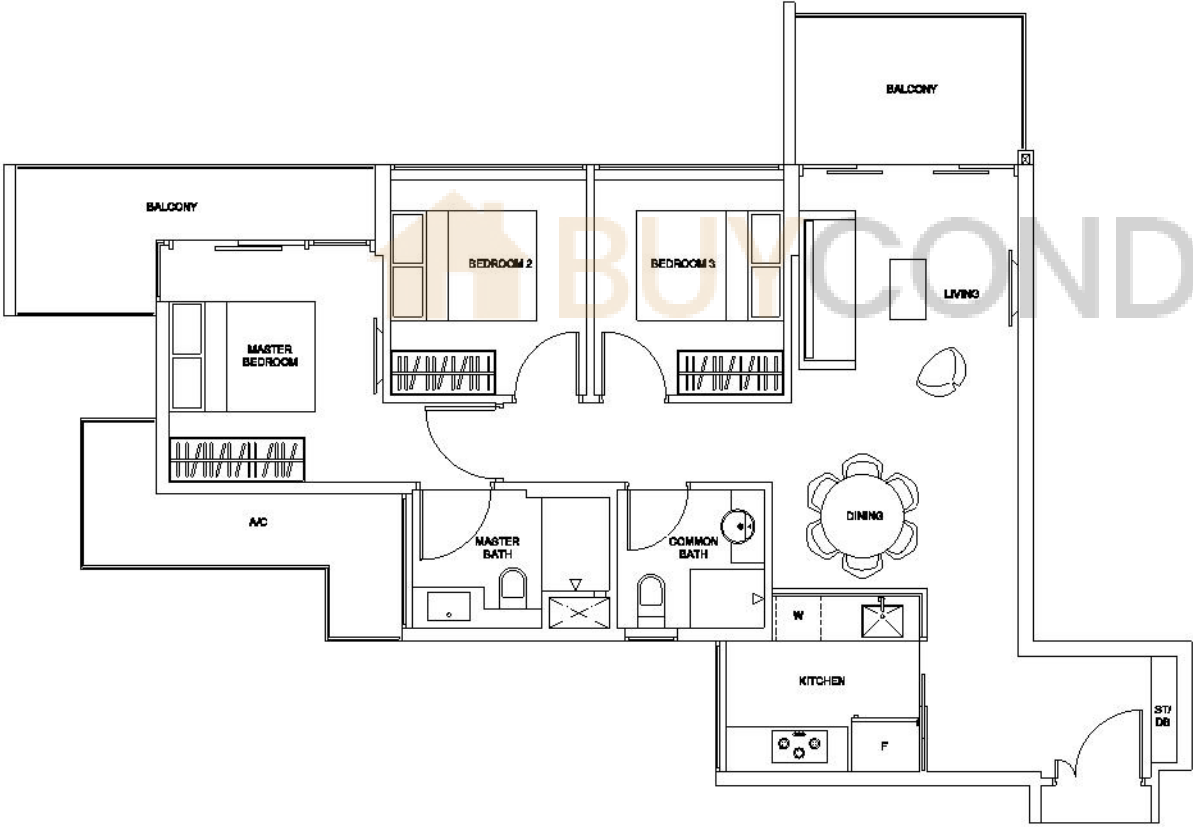

Plans are subject to change as may be required or approved by the relevant authorities. These are not drawn to scale and are for the purpose of visual presentation only. Indicated areas are estimates only and subject to final survey.

3-Bedroom

TYPE C-2a
Area: 92 sq m (include 7 sq m A/C LEDGE, 13 sq m BALCONY)
Unit(s): #11-08 TO #13-08

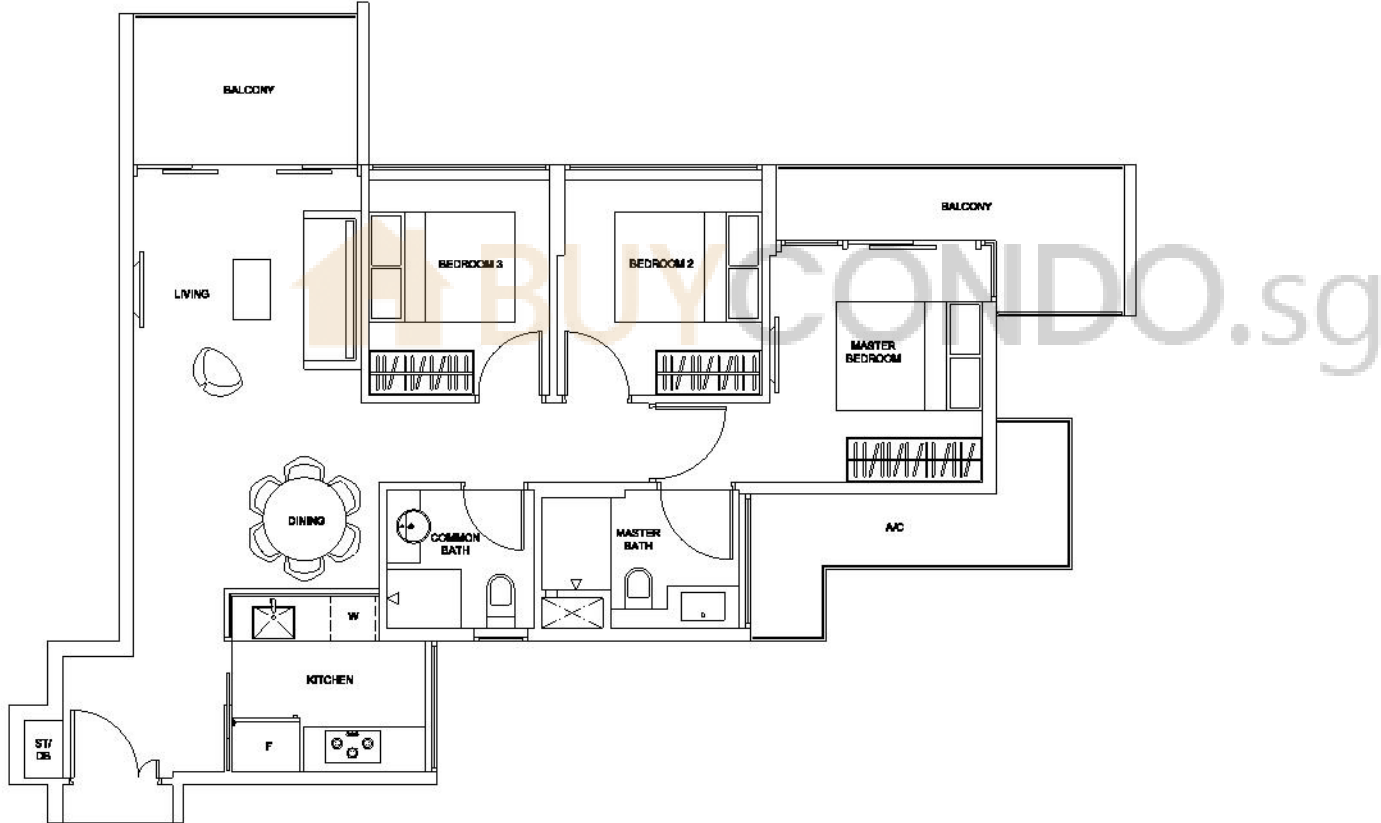

Plans are subject to change as may be required or approved by the relevant authorities. These are not drawn to scale and are for the purpose of visual presentation only. Indicated areas are estimates only and subject to final survey.

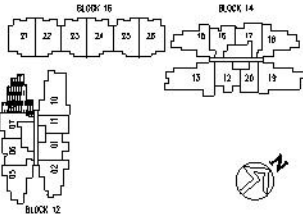

3-Bedroom

TYPE C-2aPH

Area: 92 sq m (include 7 sq m A/C LEDGE, 13 sq m BALCONY)

Unit(s): #14-08

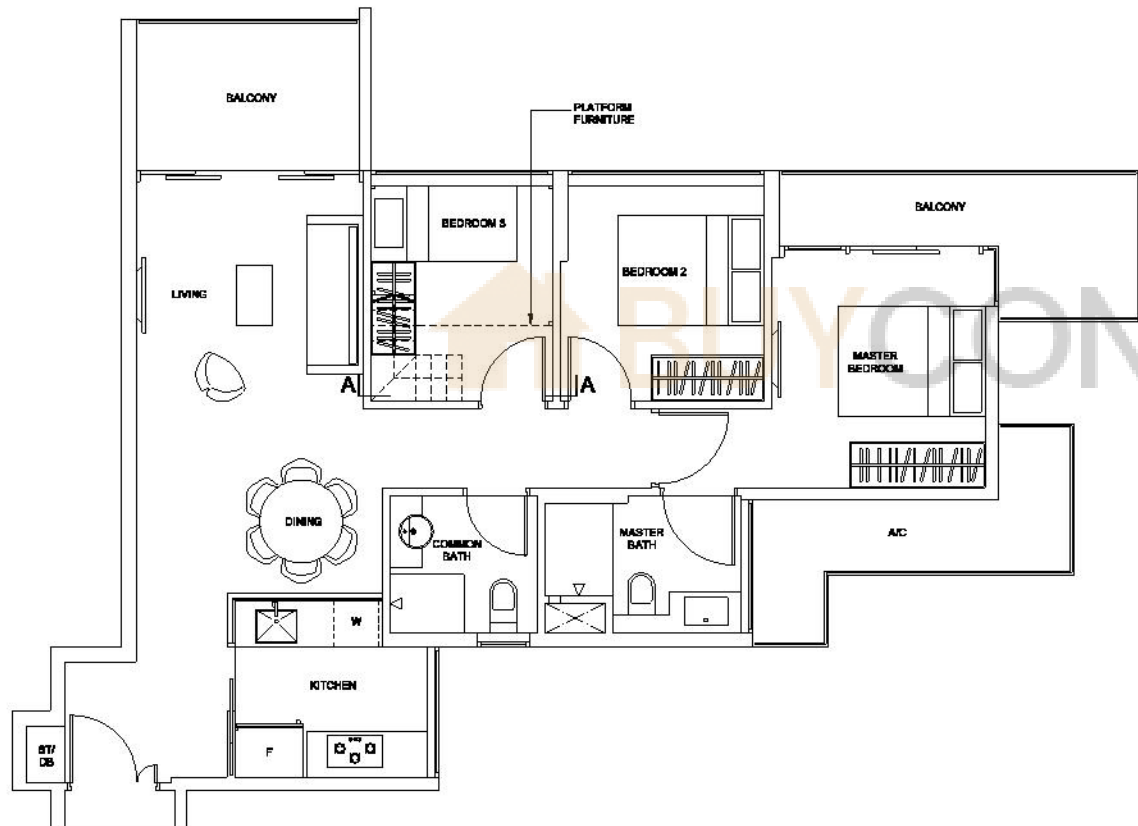

PLATFORM FURNITURE

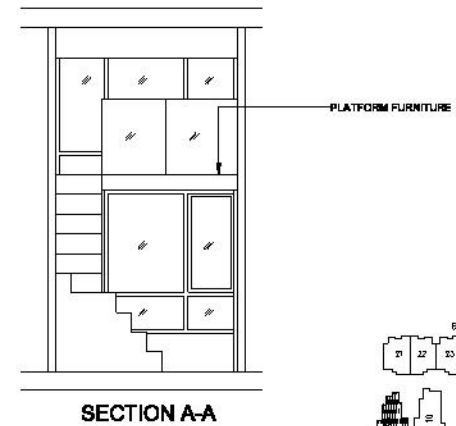
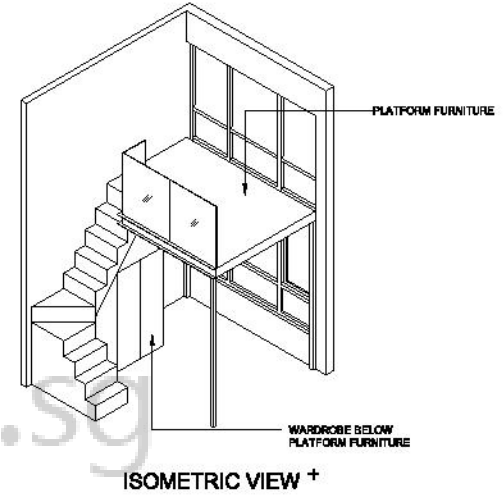

NOTE:

+ isometric views have excluded railings drawings

Plans are subject to change as may be required or approved by the relevant authorities. These are not drawn to scale and are for the purpose of visual presentation only. Indicated areas are estimates only and subject to final survey.

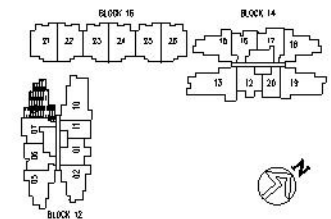

4-Bedroom

TYPE D-PH
Area: 109 sq m (include 8 sq m A/C LEDGE, 13 sq m BALCONY)
Unit(s): #14-10, #14-19

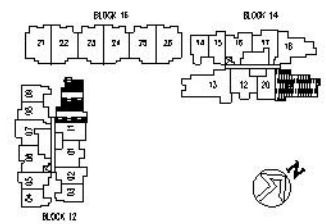
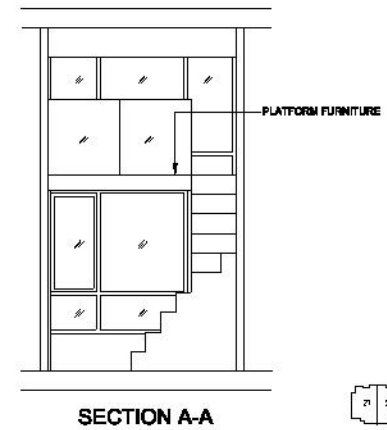
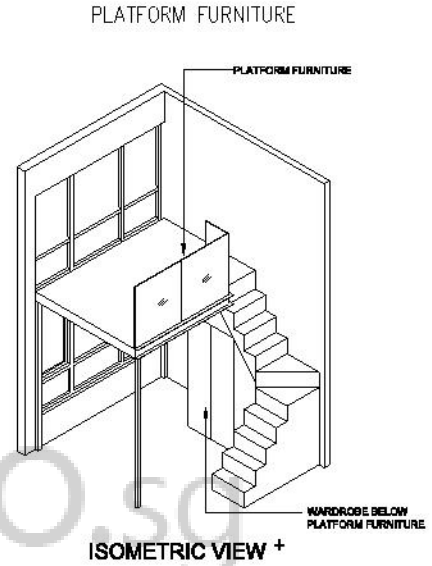
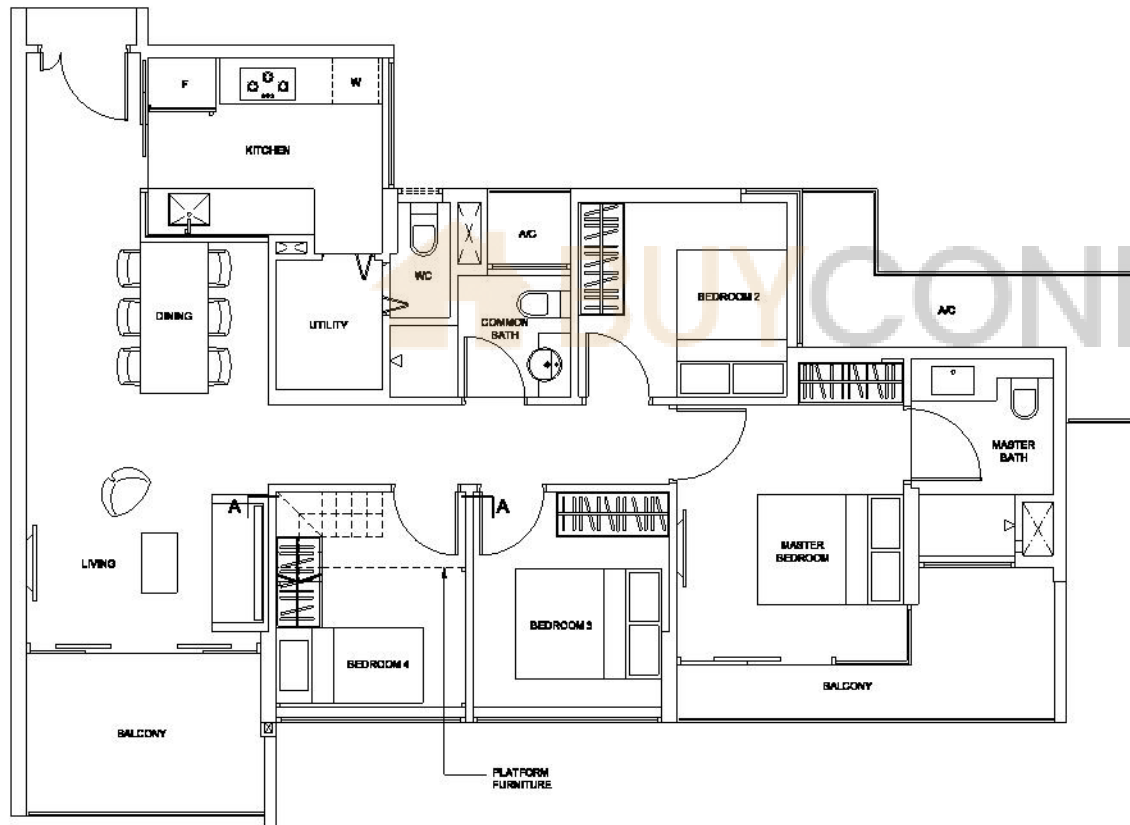

NOTE:
+ isometric views have excluded railings drawings
Plans are subject to change as may be required or approved by the relevant authorities. These are not drawn to scale and are for the purpose of visual presentation only. Indicated areas are estimates only and subject to final survey.

5-Bedroom

TYPE E-aPH
Area: 127 sq m (include 8 sq m A/C LEDGE, 15 sq m BALCONY)
Unit(s): #14-13

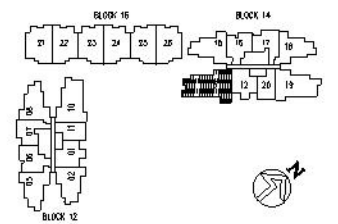
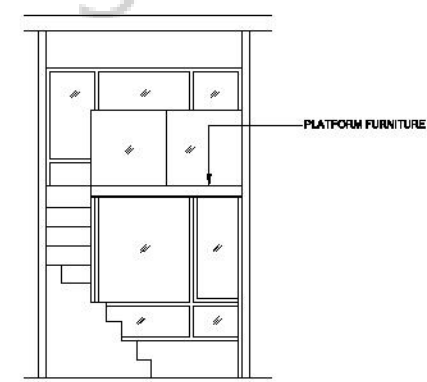
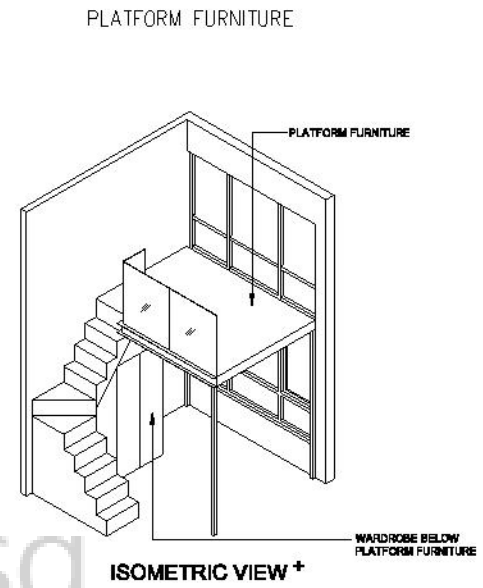
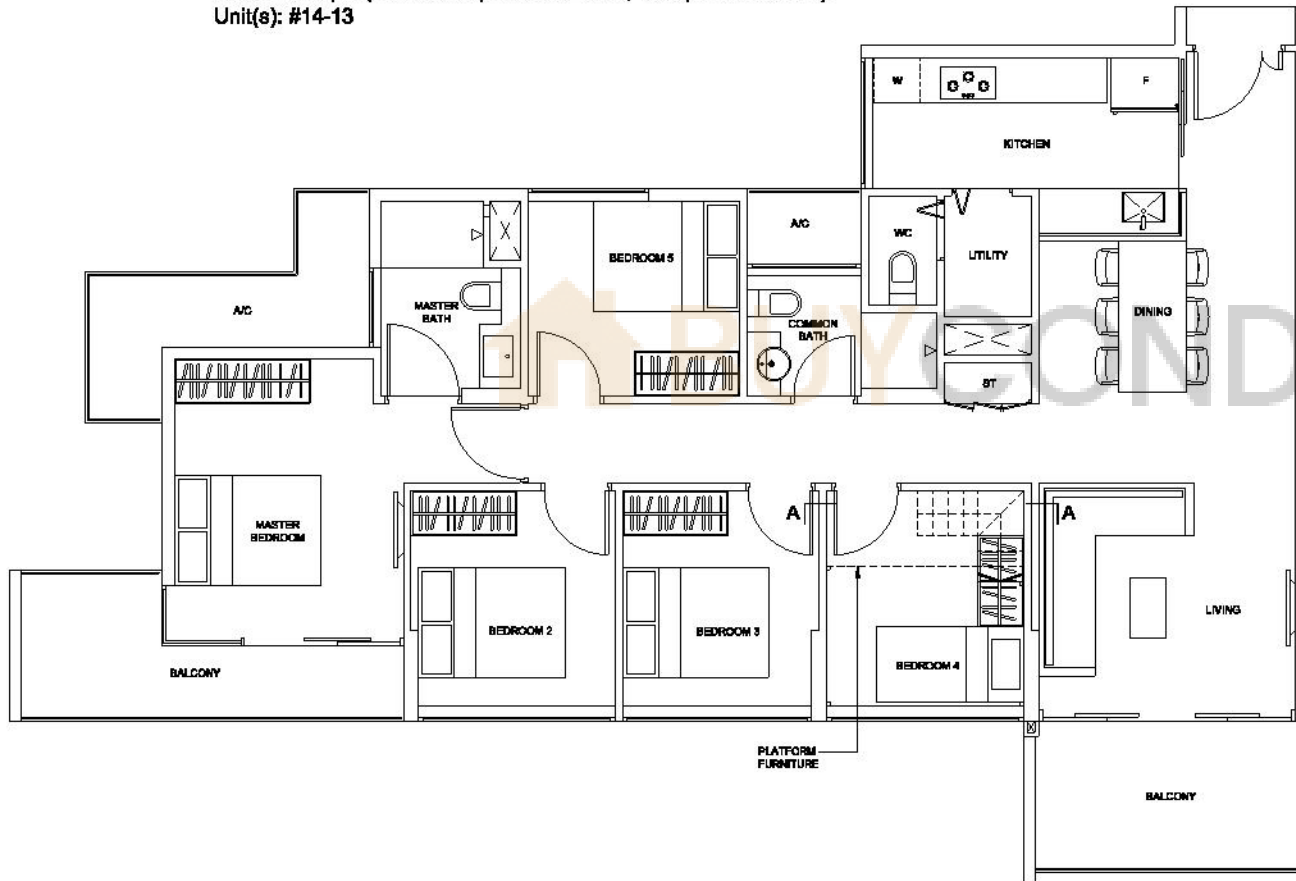

NOTE:
 + isometric views have excluded railings drawings

Plans are subject to change as may be required or approved by the relevant authorities. These are not drawn to scale and are for the purpose of visual presentation only. Indicated areas are estimates only and subject to final survey.